

**Structure ID: 10-CS-8**

**P1 MH096BAVF MH MONOBASE 13F, Custom Ht**

P5) 24" - CASTING HEIGHT - 4" P4) 96" - MH FLAT TOP SPEC. (2 - 24"Ø HOLES) - 17" P3) 96" - MH RISER - 36" P2) 96" - MH RISER - 96" P1) 96" - MH MONOBASE 13F, Custom Ht - 12" 1) CVSTENCILING 1) PSASSEMBLY 3) 96" - Conseal CS-102 1.00" 2) Hole - 48	0 lb 10005 lb 8599 lb 21443 lb 14124 lb 0 lb 0 lb 0 lb 0 lb ----- 54171 lb	<b>Structure Notes:</b> (4" TALL CASTING PROVIDED BY OTHERS)  ICAST TO INSTALL THE INTERNALS  CONTECH'S LOGO AS WELL AS THE INLET AND OUTLET MUST BE STENCILED ONTO THE STRUCTURE
Structure Total: 54171 lb		

Rim: 415.85'    Rim to Invert: 8.26'    Slack: 9.12"    Sump: 75"    Step Position:

Position	Elev	Angle	Ext. (cw)	Pipe	Pipe OD	Connector	Hole	Horz Size	Up (L)	Offset
Invert 1										
Invert 2										
Invert 3										
Invert 4										
Invert 5										
Invert 6										
Invert 7										
Invert 8										

RIGHT-SIDE UP VIEW (int. dimensions)

UPSIDE-DOWN VIEW (int. dimensions)

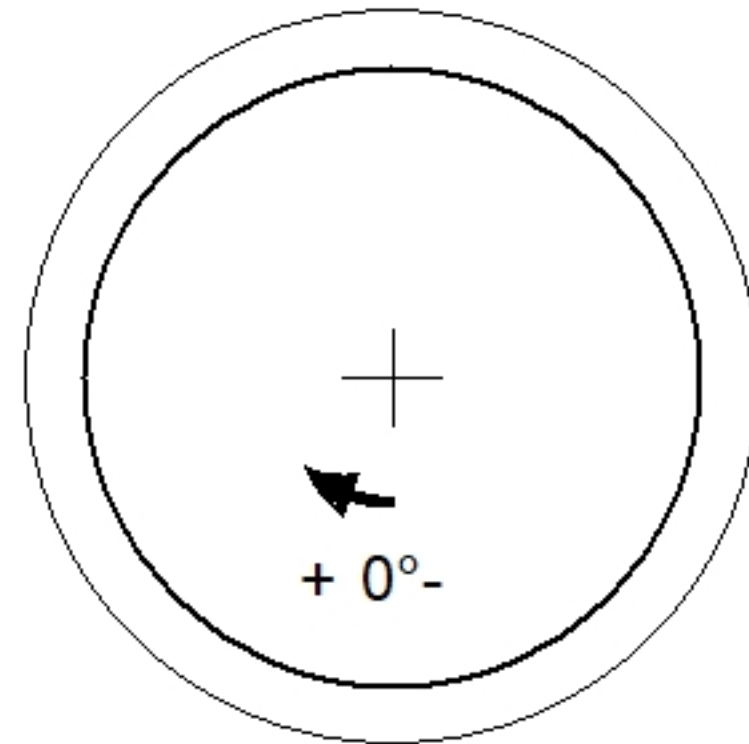
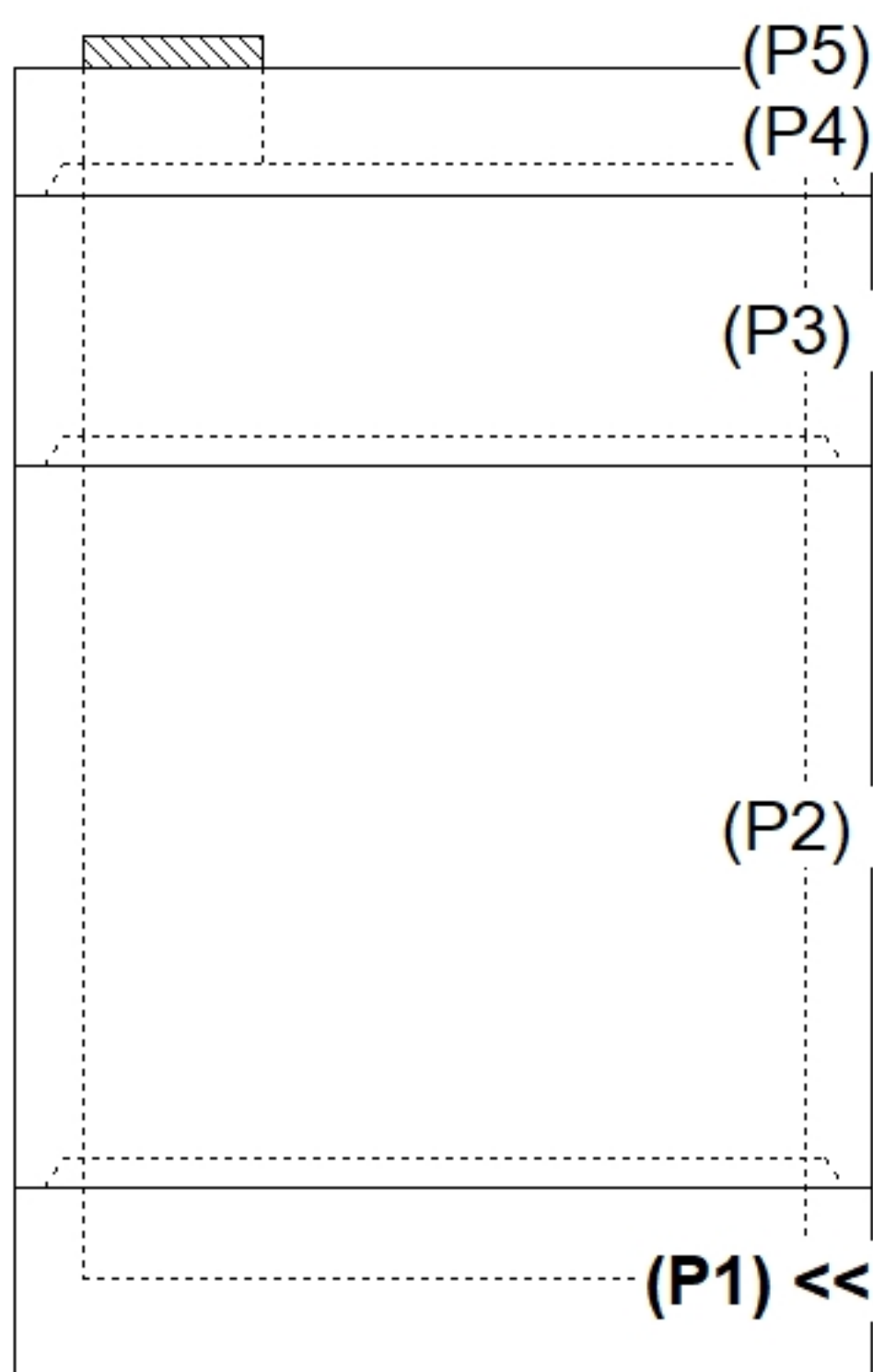

INSIDE WALL DIMENSIONS

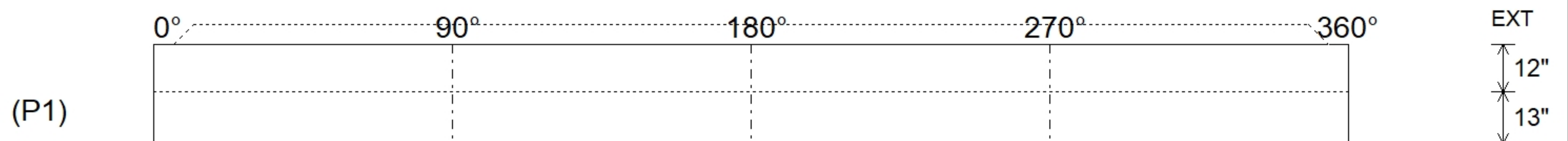

Coating (Int):	Seam Up: Tongue	Wall Thickness: 9"	Height (Int): 12"
Coating (Ext):	Seam Dn: n/a	Floor Height: 13"	Height (Ext): 25"
		Weight (Net): 14124 lb	
		Volume (Net): 3.61cu.yd	

**Structure ID: 10-CS-8**

**P1 MH096BAVF**

**MH MONOBASE 13F, Custom Ht**

P5) 24" - CASTING HEIGHT - 4" P4) 96" - MH FLAT TOP SPEC. (2 - 24"Ø HOLES) - 17" P3) 96" - MH RISER - 36" P2) 96" - MH RISER - 96" P1) 96" - MH MONOBASE 13F, Custom Ht - 12" 1) CVSTENCILING 1) PSASSEMBLY 3) 96" - Conseal CS-102 1.00" 2) Hole - 48	0 lb 10005 lb 8599 lb 21443 lb 14124 lb 0 lb 0 lb 0 lb 0 lb ----- 54171 lb	<b>Structure Notes:</b> (4" TALL CASTING PROVIDED BY OTHERS)  ICAST TO INSTALL THE INTERNALS  CONTECH'S LOGO AS WELL AS THE INLET AND OUTLET MUST BE STENCILED ONTO THE STRUCTURE
Structure Total: 54171 lb		

Rim: 415.85'    Rim to Invert: 8.26'    Slack: 9.12"    Sump: 75"    Step Position:

Position	Elev	Angle	Ext. (cw)	Pipe	Pipe OD	Connector	Hole	Horz Size	Up (L)	Offset
Invert 1										
Invert 2										
Invert 3										
Invert 4										
Invert 5										
Invert 6										
Invert 7										
Invert 8										

RIGHT-SIDE UP VIEW (int. dimensions)

UPSIDE-DOWN VIEW (int. dimenions)

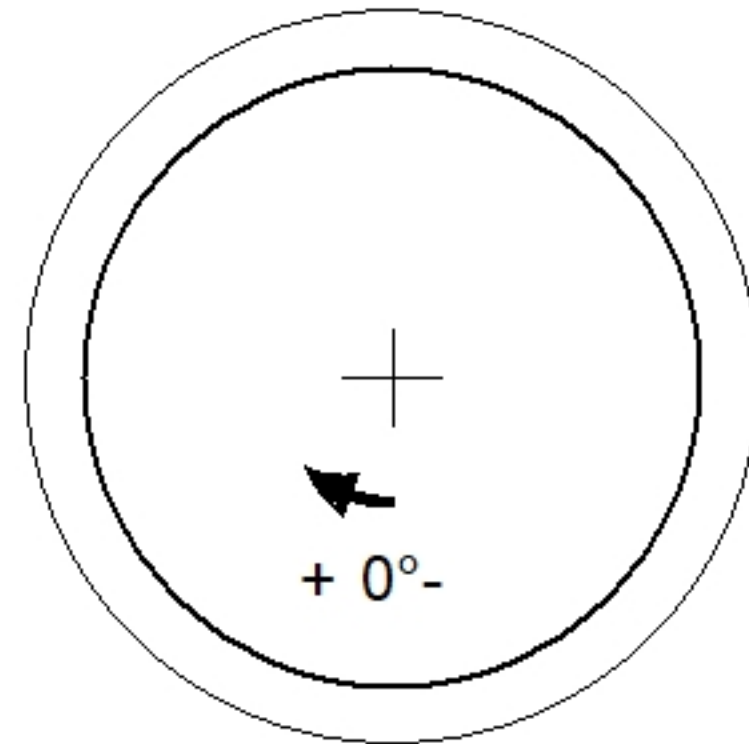
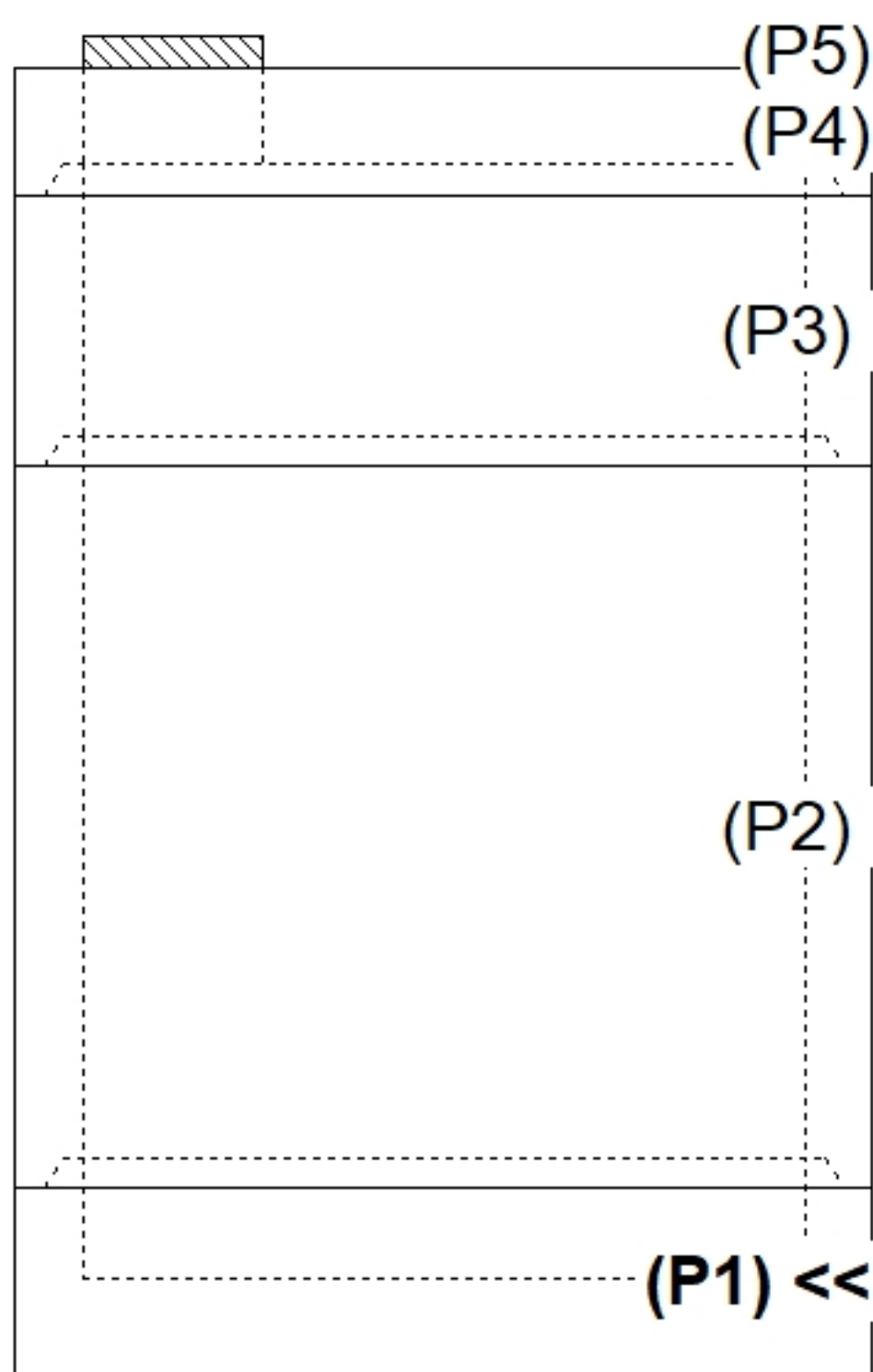

INSIDE WALL DIMENSIONS

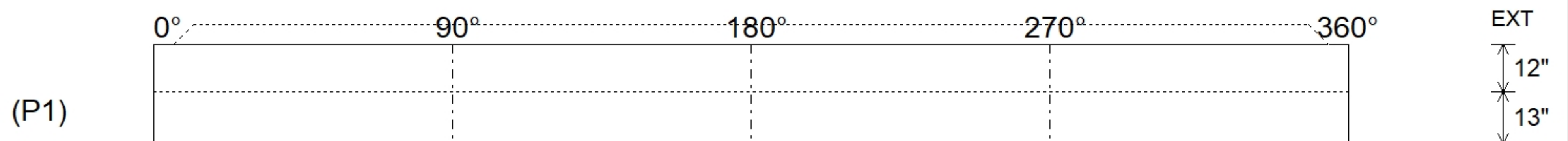

Coating (Int):	Seam Up: Tongue	Wall Thickness: 9"	Height (Int): 12"	Weight (Net): 14124 lb Volume (Net): 3.61cu.yd
Coating (Ext):	Seam Dn: n/a	Floor Height: 13"	Height (Ext): 25"	

**Structure ID: 10-CS-8**

**P2 MH096RS96 MH RISER**

P5) 24" - CASTING HEIGHT - 4" P4) 96" - MH FLAT TOP SPEC. (2 - 24"Ø HOLES) - 17" P3) 96" - MH RISER - 36" P2) 96" - MH RISER - 96" P1) 96" - MH MONOBASE 13F, Custom Ht - 12" 1) CVSTENCILING 1) PSASSEMBLY 3) 96" - Conseal CS-102 1.00" 2) Hole - 48	0 lb 10005 lb 8599 lb 21443 lb 14124 lb 0 lb 0 lb 0 lb 0 lb ----- 54171 lb	<b>Structure Notes:</b> (4" TALL CASTING PROVIDED BY OTHERS)  ICAST TO INSTALL THE INTERNALS  CONTECH'S LOGO AS WELL AS THE INLET AND OUTLET MUST BE STENCILED ONTO THE STRUCTURE
--	--	--

Structure Total: 54171 lb

Rim: 415.85'    Rim to Invert: 8.26'    Slack: 9.12"    Sump: 75"    Step Position:

Position	Elev	Angle	Ext. (cw)	Pipe	Pipe OD	Connector	Hole	Horz Size	Up ( )	Offset
Invert 1	407.59'	270°	268.606"	36" RCP B WALL	44"	Hole 48	48"	50.265"	52"	0"
Invert 2	407.59'	90°	89.535"	36" RCP B WALL	44"	Hole 48	48"	50.265"	52"	0"
Invert 3										
Invert 4										
Invert 5										
Invert 6										
Invert 7										
Invert 8										

**RIGHT-SIDE UP VIEW (int. dimensions)**

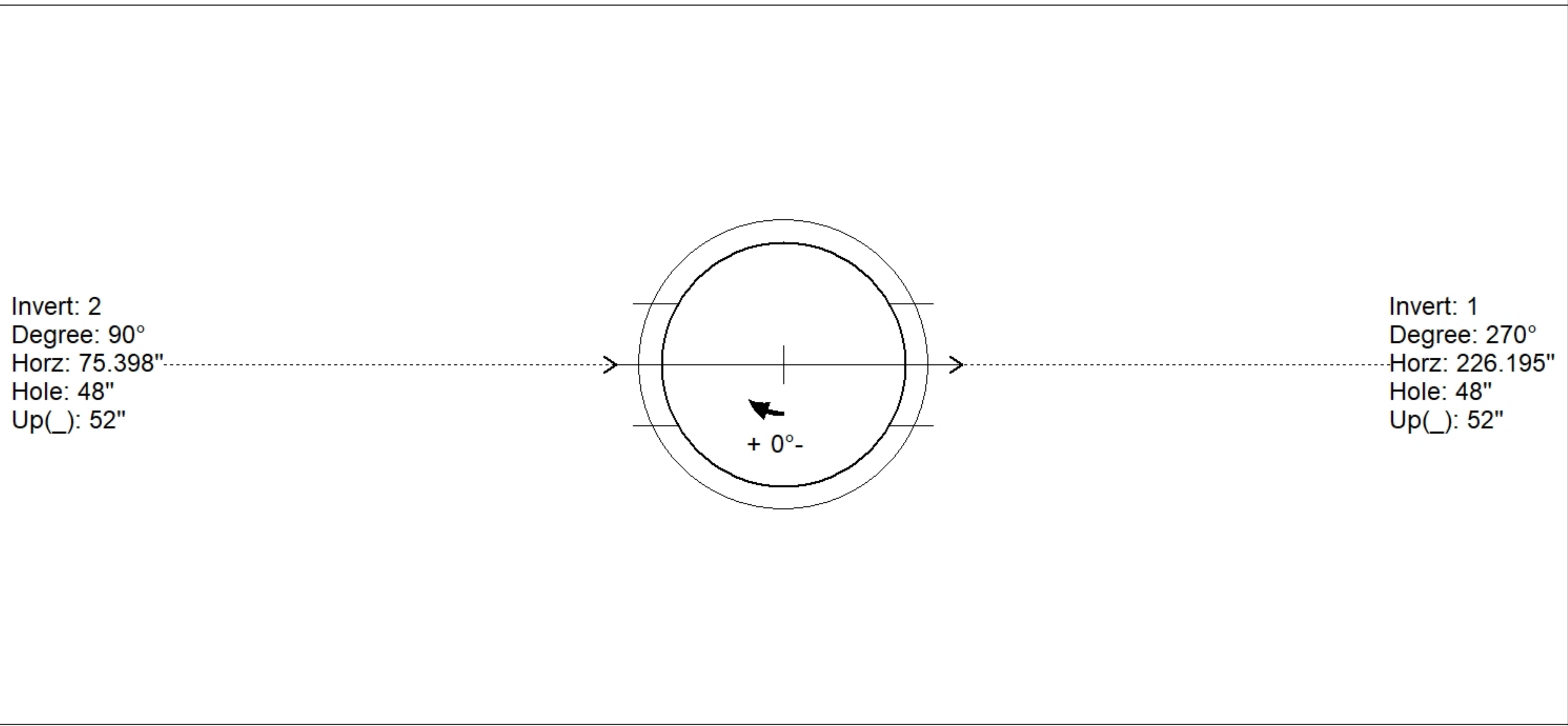
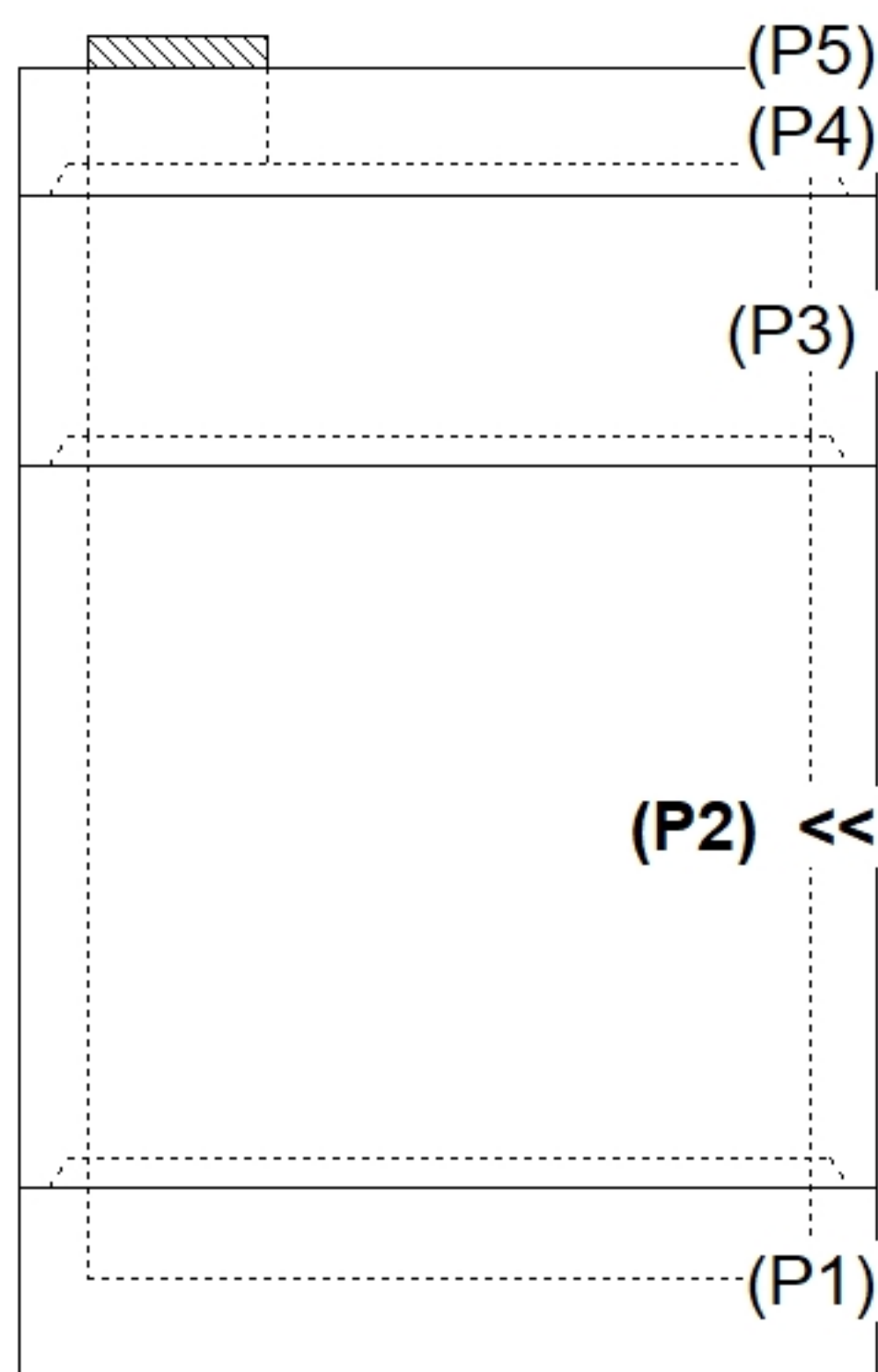

**INSIDE WALL DIMENSIONS**

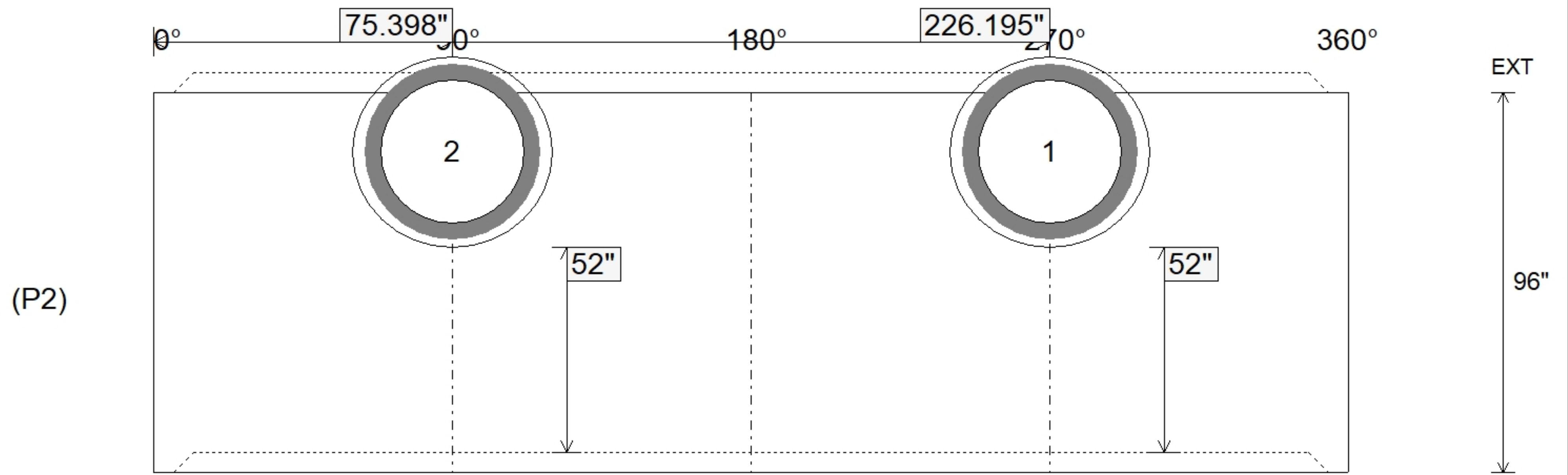

Coating (Int):	Seam Up: Tongue Seam Dn: Groove	Wall Thickness: 9" Floor Height: 0"	Height (Int): 96" Height (Ext): 96"
Coating (Ext):			Weight (Net): 21443 lb Volume (Net): 5.48cu.yd

**Structure ID: 10-CS-8**

**P3 MH096RS36 MH RISER**

P5) 24" - CASTING HEIGHT - 4" P4) 96" - MH FLAT TOP SPEC. (2 - 24"Ø HOLES) - 17" P3) 96" - MH RISER - 36" P2) 96" - MH RISER - 96" P1) 96" - MH MONOBASE 13F, Custom Ht - 12" 1) CVSTENCILING 1) PSASSEMBLY 3) 96" - Conseal CS-102 1.00" 2) Hole - 48	0 lb 10005 lb 8599 lb 21443 lb 14124 lb 0 lb 0 lb 0 lb 0 lb ----- 54171 lb	<b>Structure Notes:</b> (4" TALL CASTING PROVIDED BY OTHERS)  ICAST TO INSTALL THE INTERNALS  CONTECH'S LOGO AS WELL AS THE INLET AND OUTLET MUST BE STENCILED ONTO THE STRUCTURE
Structure Total: 54171 lb		

Rim: 415.85'    Rim to Invert: 8.26'    Slack: 9.12"    Sump: 75"    Step Position:

Position	Elev	Angle	Ext. (cw)	Pipe	Pipe OD	Connector	Hole	Horz Size	Up ( )	Offset
Invert 1	407.59'	270°	268.606"	36" RCP B WALL	44"	Hole 48	48"	50.265"	-44"	0"
Invert 2	407.59'	90°	89.535"	36" RCP B WALL	44"	Hole 48	48"	50.265"	-44"	0"
Invert 3										
Invert 4										
Invert 5										
Invert 6										
Invert 7										
Invert 8										

**RIGHT-SIDE UP VIEW (int. dimensions)**

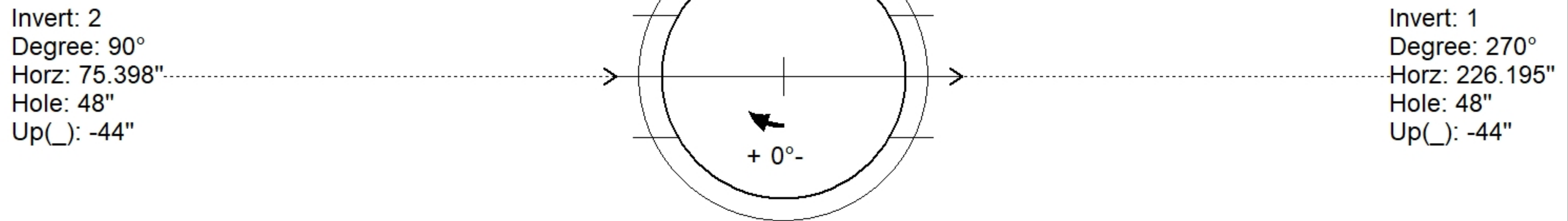
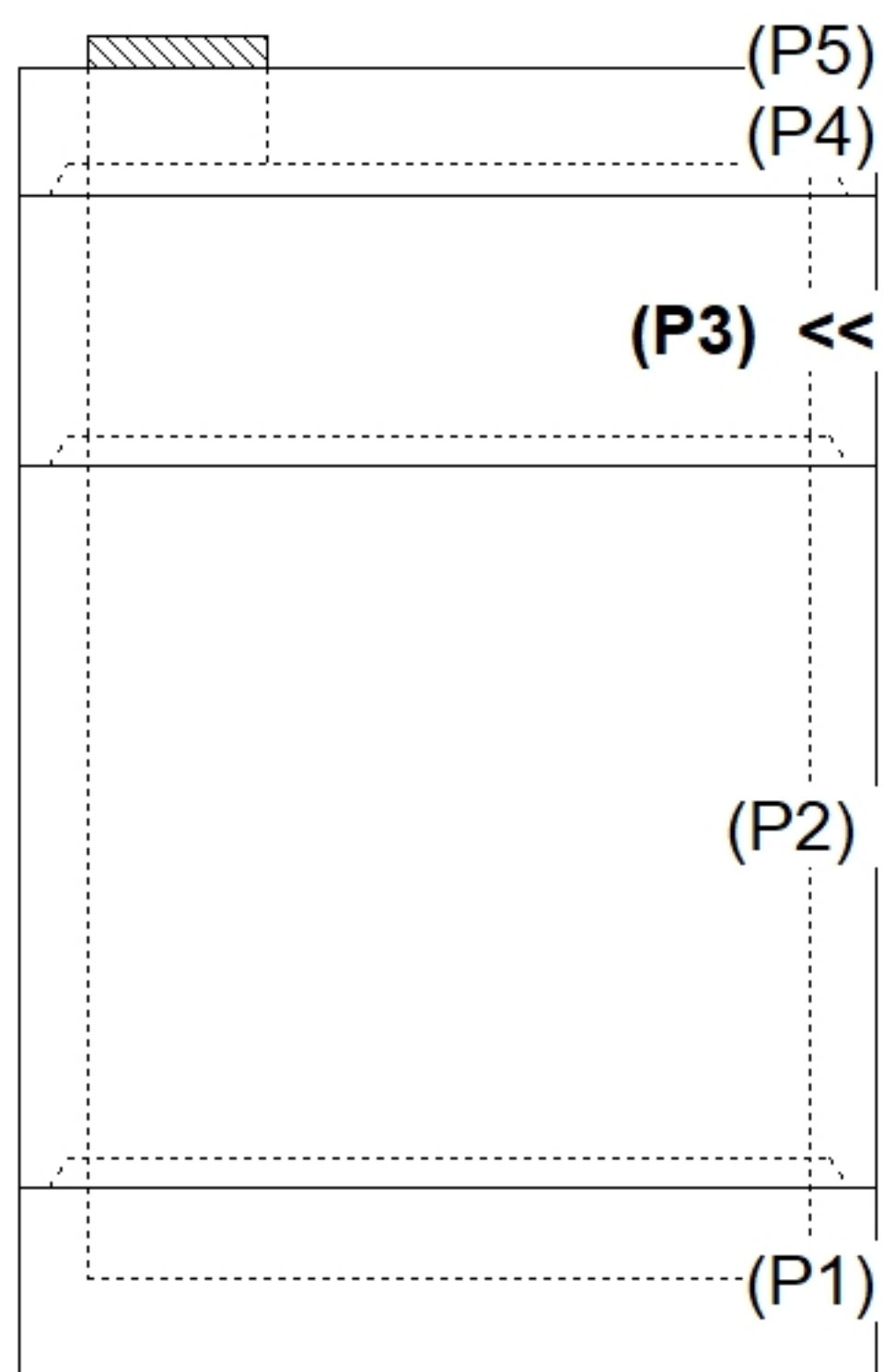

**INSIDE WALL DIMENSIONS**

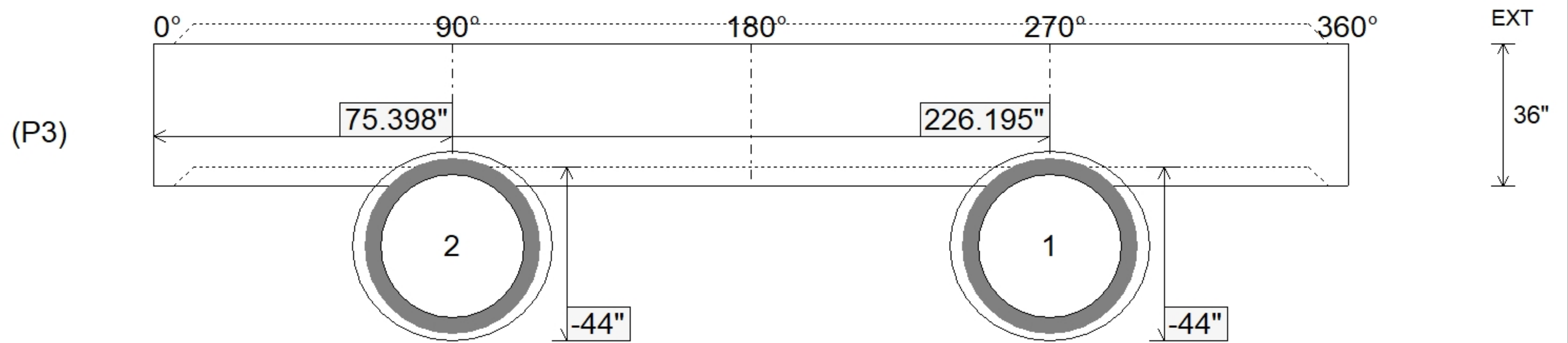

Coating (Int): Coating (Ext):	Seam Up: Tongue Seam Dn: Groove	Wall Thickness: 9" Floor Height: 0"	Height (Int): 36" Height (Ext): 36"	Weight (Net): 8599 lb Volume (Net): 2.2cu.yd
----------------------------------	------------------------------------	--	--	---

Job Name: 25-3422 - 861485 Kroger L-756  
 Job Location: Owensboro, KY  
 Contractor: Contech Engineering Solutions

Plant: Beaver Dam  
 9/25/2025 8:07:58 AM

Tech: J. Coppage  
 PC: T. Sekula



**Structure ID: 10-CS-8**

**P4 MH096LD17SP**

**MH FLAT TOP SPEC. (2 - 24"Ø HOLES)**

P5) 24" - CASTING HEIGHT - 4"	0 lb
P4) 96" - MH FLAT TOP SPEC. (2 - 24"Ø HOLES) - 17"	10005 lb
P3) 96" - MH RISER - 36"	8599 lb
P2) 96" - MH RISER - 96"	21443 lb
P1) 96" - MH MONOBASE 13F, Custom Ht - 12"	14124 lb
1) CVSTENCILING	0 lb
1) PSASSEMBLY	0 lb
3) 96" - Conseal CS-102 1.00"	0 lb
2) Hole - 48	0 lb
Structure Total:	54171 lb

Structure Notes:  
 (4" TALL CASTING PROVIDED BY OTHERS)  
  
 ICAST TO INSTALL THE INTERNALS  
  
 CONTECH'S LOGO AS WELL AS THE  
 INLET AND OUTLET MUST BE  
 STENCILED ONTO THE STRUCTURE

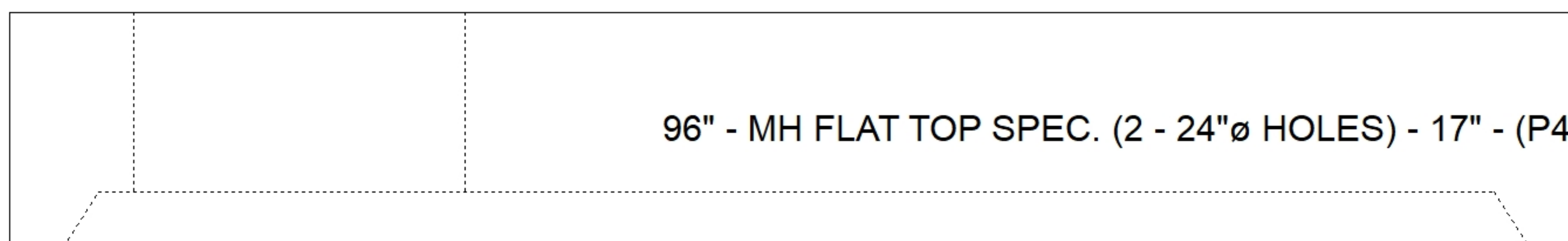
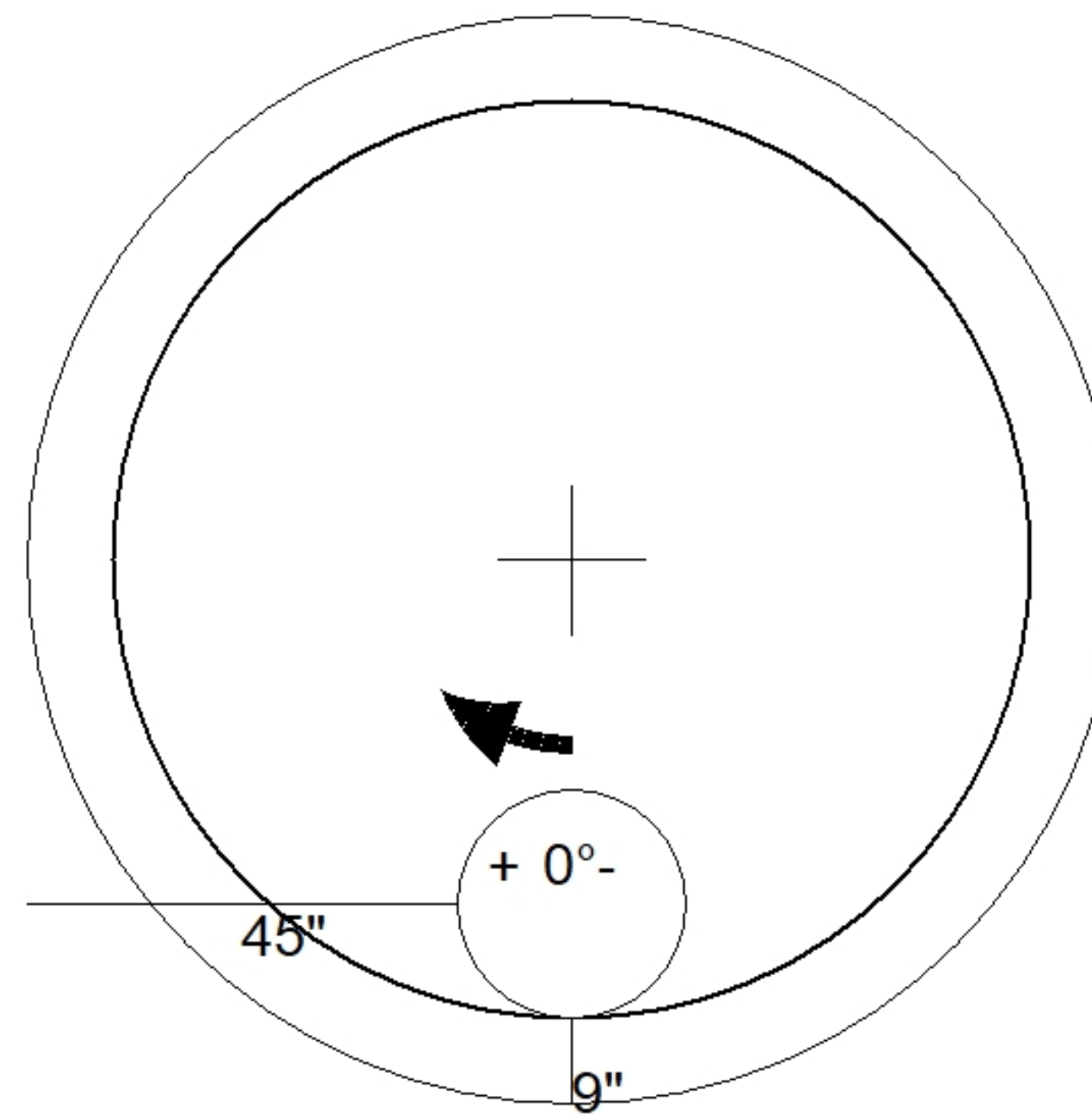

Coating (Int): Coating (Ext):	Seam Up: Flat Seam Dn: Groove	Wall Thickness: 9"	Height (Ext): 17"	Weight (Net): 10005 lb Volume (Net): 2.56cu.yd
----------------------------------	----------------------------------	--------------------	-------------------	---