

Structure ID: 10-CS-8

P3 MH096RS36

MH RISER T/G

P5) 24" - CASTING HEIGHT - 4" P4) 96" - MH FLAT TOP SPEC. (2 - 24"Ø HOLES) F/G - 17" P3) 96" - MH RISER T/G - 36" P2) 96" - MH RISER T/G - 96" P1) 96" - MH MONOBASE 13F, Custom Ht T/n - 12" 1) CVSTENCILING 1) PSASSEMBLY 3) 96" - Conseal CS-102 1.00" 2) Hole - 48	0 lb 10005 lb 8599 lb 21443 lb 14124 lb 0 lb 0 lb 0 lb 0 lb ----- 54171 lb	Structure Notes: (4" TALL CASTING PROVIDED BY OTHERS) ICAST TO INSTALL THE INTERNALS CONTECH'S LOGO AS WELL AS THE INLET AND OUTLET MUST BE STENCILED ONTO THE STRUCTURE
Structure Total: 54171 lb		

Rim: 415.85' Rim to Invert: 8.26' Slack: 9.12" Sump: 75" Step Position:

Position	Elev	Angle	Ext. (cw)	Pipe	Pipe OD	Connector	Hole	Horz Size	Up ()	Offset
Invert 1	407.59'	270°	268.625"	36" RCP B WALL	44"	Hole 48	48"	50.265"	-44"	0"
Invert 2	407.59'	90°	89.5"	36" RCP B WALL	44"	Hole 48	48"	50.265"	-44"	0"
Invert 3										
Invert 4										
Invert 5										
Invert 6										
Invert 7										
Invert 8										

RIGHT-SIDE UP VIEW (int. dimensions)

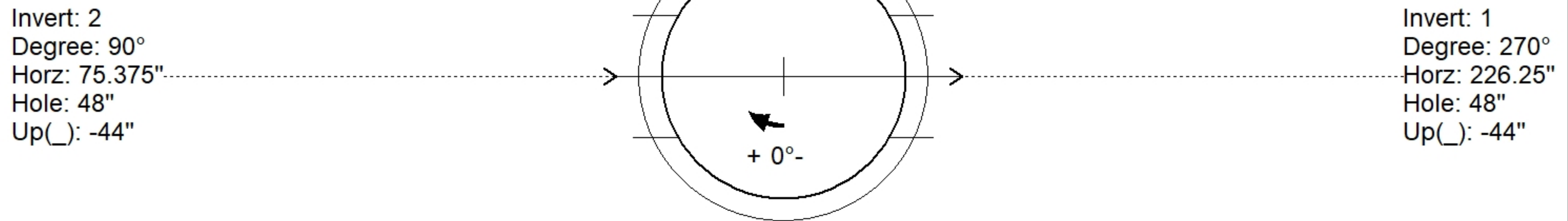
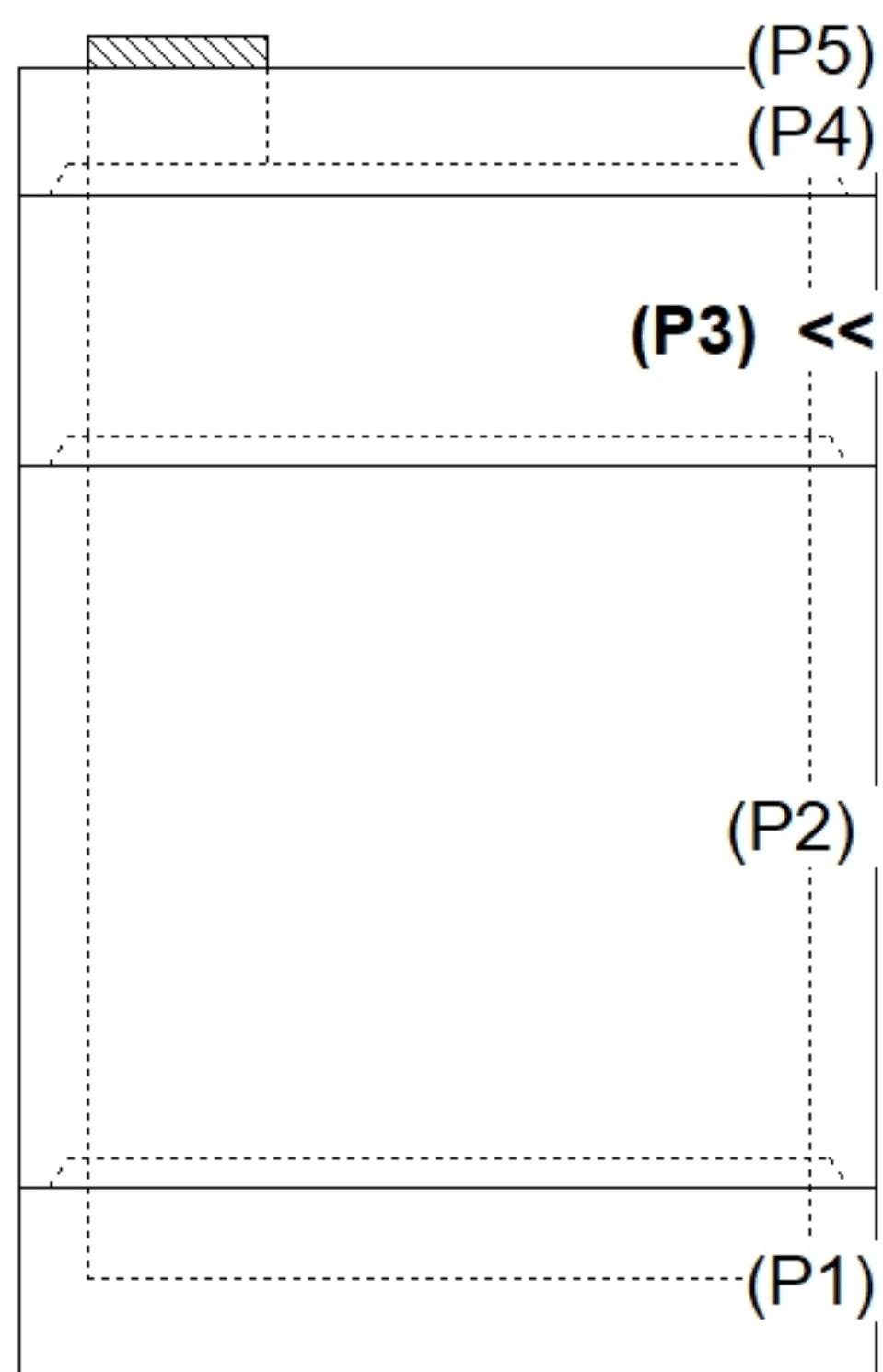

INSIDE WALL DIMENSIONS

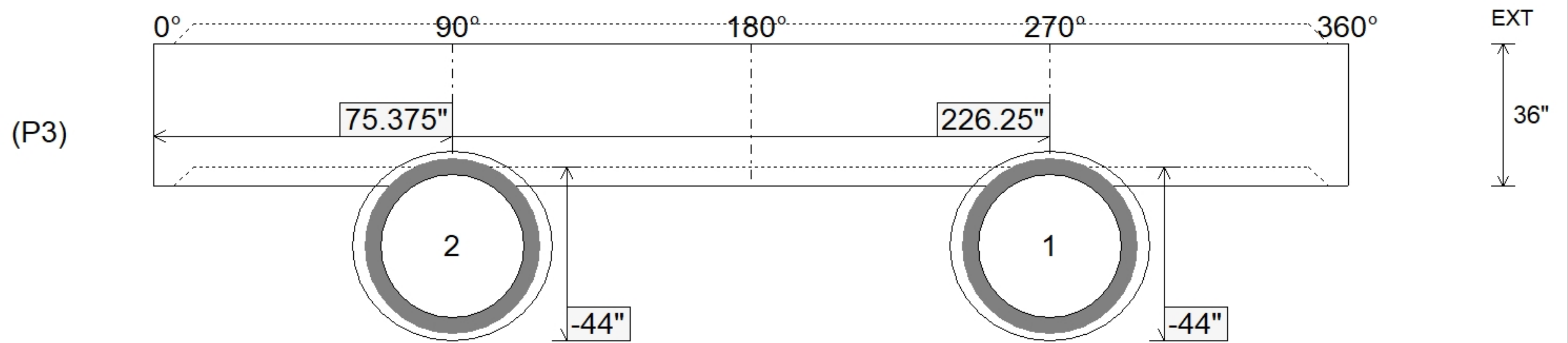

Coating (Int): Coating (Ext):	Seam Up: Tongue Seam Dn: Groove	Wall Thickness: 9" Floor Height: 0"	Height (Int): 36" Height (Ext): 36"	Weight (Net): 8599 lb Volume (Net): 2.2cu.yd
----------------------------------	------------------------------------	--	--	---