

Job Name: 25-3419 - MSU Learning Commons  
 Job Location: Murray, KY  
 Contractor: Sykes Family Farms, LLC.

Plant: 100

2/24/2026 8:27:21 AM

Tech: J. Horsley - F

PC: E. Bradley



**Structure ID: INL 15**

**P1 MH048BAVF**

**MH BASE Custom Ht T/n**

- P3) 32" x 32" - CASTING HEIGHT - 3"
- P2) 48" - MH FLAT TOP w/32"x32" Hole F/G - 12"
- P1) 48" - MH BASE Custom Ht T/n - 67"
- 1) CASTING - HOE 595 F/G
- 1) 48" - Conseal CS-102 1.00"
- 1) 32" x 32" - Conseal CS-102 1.00"
- 2) Hole - 22
- 1) Hole - 8
- 5) MH Step ML-10-TDS-NCR - 10"

0 lb  
 1629 lb  
 5660 lb  
 376 lb  
 0 lb  
 0 lb  
 0 lb  
 0 lb  
 0 lb  
 0 lb  
 -----  
 Structure Total: 7666 lb

- Structure Notes:**
1. PER ASTM C-478 SPECIFICATIONS
  2. CONCRETE: 4,000 PSI AT 28 DAYS
  3. REINFORCEMENT: PER ASTM A615
  4. NO STORM INVERT
  5. STEPS AT 282 DEGREES
  6. HOE 595 FRAME & GRATES SUPPLIED BY ICAST

Rim: 539.5' Rim to Invert: 6.7' Slack: 0.65" Sump: 2.25" Step Position: 282°

| Position | Elev   | Angle | Ext. (cw) | Pipe                | Pipe OD | Connector | Hole | Horz Size | Up ( )  | Offset |
|----------|--------|-------|-----------|---------------------|---------|-----------|------|-----------|---------|--------|
| Invert 1 | 532.8' | 0°    | 0"        | 18" HDPE DR11       | 18"     | Hole 22   | 22"  | 22.854"   | 0.5"    | 0"     |
| Invert 2 | 532.8' | 168°  | 85"       | 15" RCP B WALL      | 19.5"   | Hole 22   | 22"  | 22.854"   | 0"      | 0"     |
| Invert 3 | 537.2' | 90°   | 45.5"     | 6" HDPE (perf pipe) | 6.9"    | Hole 8    | 8"   | 8.038"    | 54.625" | 0"     |
| Invert 4 |        |       |           |                     |         |           |      |           |         |        |
| Invert 5 |        |       |           |                     |         |           |      |           |         |        |
| Invert 6 |        |       |           |                     |         |           |      |           |         |        |
| Invert 7 |        |       |           |                     |         |           |      |           |         |        |
| Invert 8 |        |       |           |                     |         |           |      |           |         |        |

RIGHT-SIDE UP VIEW (int. dimensions)

UPSIDE-DOWN VIEW (int. dimensions)

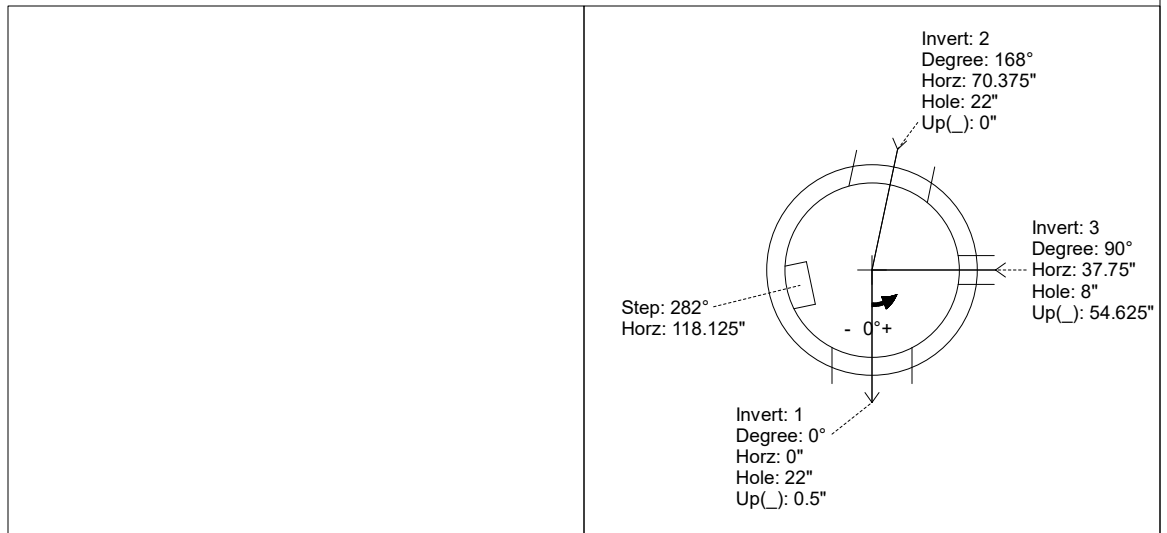
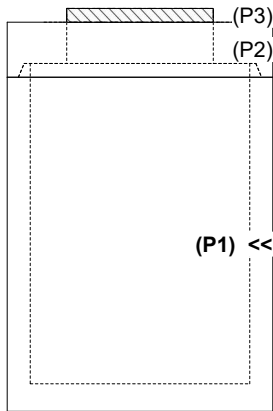

INSIDE WALL DIMENSIONS

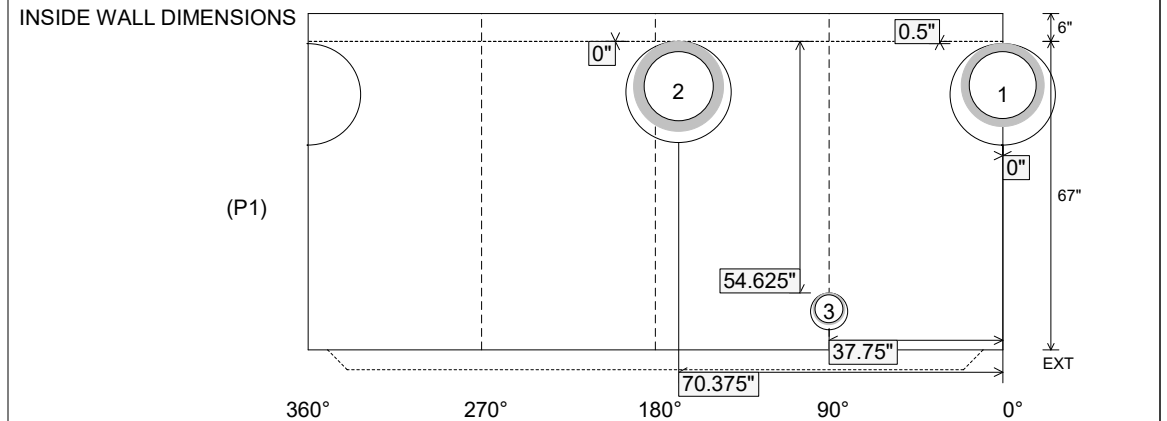

Coating (Int):  
 Coating (Ext):

Seam Up: Tongue  
 Seam Dn: n/a

Wall Thickness: 5"  
 Floor Height: 6"

Height (Int): 67"  
 Height (Ext): 73"

Weight (Net): 5660 lb  
 Volume (Net): 1.45cu.yd