

Structure ID: INL 1

P1 BX24240606VF

BOX BASE 6inW, 6inF, Variable Ht F/n

- P2) 24" x 24" - CASTING HEIGHT - 5"
- P1) 24" x 24" - BOX BASE 6inW, 6inF, Variable Ht F/n - 32"
- 1) CASTING - HOE KY-465 SET (CBI TY F)
- 1) 24" x 24" - Conseal CS-102 1.00"
- 2) Hole - 20
- 1) Hole - 8

	0 lb
	2244 lb
	465 lb
	0 lb
	0 lb
	0 lb
Structure Total:	2709 lb

- Structure Notes:
1. PER ASTM C-913 SPECIFICATIONS
 2. CONCRETE: 4,000 PSI AT 28 DAYS
 3. REINFORCEMENT: #5 BAR @ 12" C.C. E.W. (GRADE 60) - 2" MIN. REBAR CLEARANCE (TYP)
 4. NO STORM INVERT
 5. NO STEPS
 6. HOE KY-465 FRAME, GRATE, & CURB HOOD SUPPLIED BY ICAST

Rim: 538.8' Rim to Invert: 3' Slack: 0.25" Sump: 1.25" Step Position:

Position	Elev	Angle	Ext. (cw)	Pipe	Pipe OD	Connector	Hole	Horz Size	Up ()	Offset
Invert 1	535.8'	0°	18"	15" HDPE	17.6"	Hole 20	20"	20"	0"	0"
Invert 2	535.8'	90°	18"	15" HDPE	17.6"	Hole 20	20"	20"	0"	0"
Invert 3	537.3'	180°	18"	6" HDPE (perf pipe)	6.9"	Hole 8	8"	8"	18.75"	0"
Invert 4										
Invert 5										
Invert 6										
Invert 7										
Invert 8										

RIGHT-SIDE UP VIEW (int. dimensions)

UPSIDE-DOWN VIEW (int. dimensions)

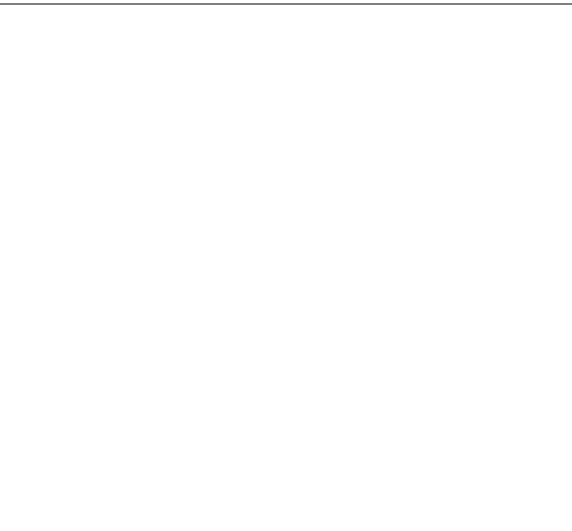
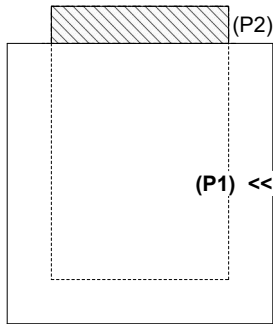

INSIDE WALL DIMENSIONS

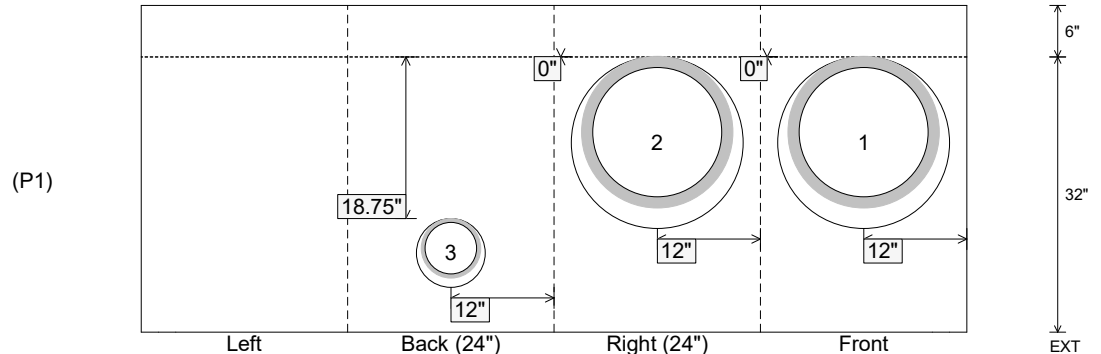

Coating (Int): Coating (Ext):	Seam Up: Flat Seam Dn: n/a	Wall Thickness: 6" Floor Height: 6"	Height (Int): 32" Height (Ext): 38"	Weight (Net): 2244 lb Volume (Net): 0.57cu.yd
----------------------------------	-------------------------------	--	--	--