

**TOP VIEW**

**GENERAL NOTES:**

1. DESIGN LOADING – AASHTO HS-20.
2. DESIGN SPECIFICATIONS – ACI 318-14.
3. CONCRETE: 5,000 PSI AT 28 DAYS. CONCRETE.
4. JOINT SEALANT SHALL CONFORM TO ASTM C-990 OR ASTM C-443.
5. REINFORCING: AS SHOWN BELOW (GRADE 60) SEE CONTECH DRAWING SF8X16 FOR ADDITIONAL INFORMATION. PER ASTM A615 (GRADE 60).
6. WEIGHTS:  
 FIRST POUR = 11,093 LBS  
 SECOND POUR = 21,752 LBS.  
 TOTAL = 32,845 LBS
7. STRUCTURE TO HAVE INTERNALS INSTALLED BY ICAST.
8. CONTECH'S LOGO AS WELL AS THE INLETS AND OUTLETS TO BE STENCILED ONTO THE STRUCTURE.

**FIRST POUR DRAWING**

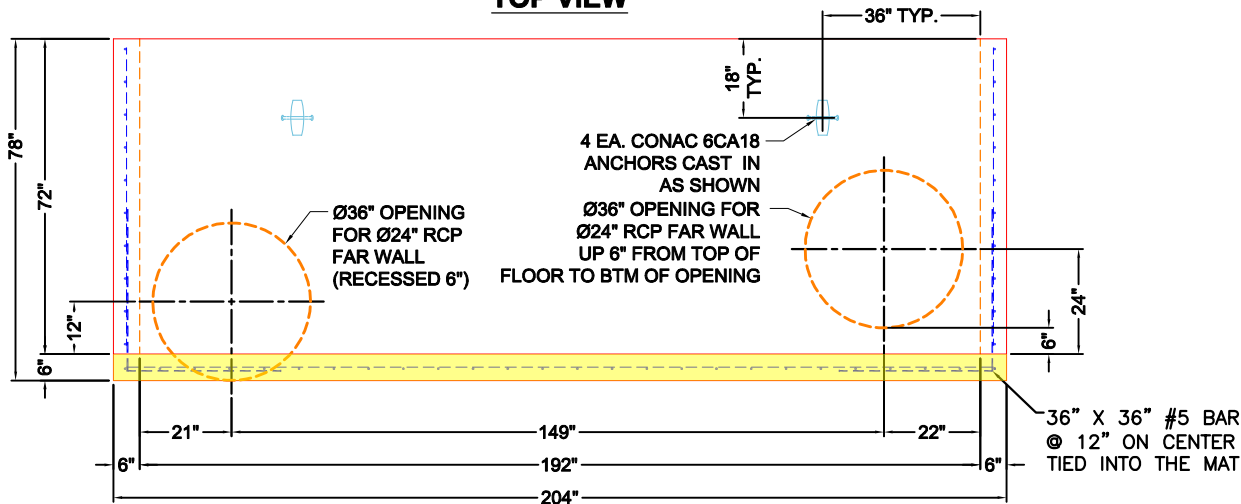

**FRONT VIEW**

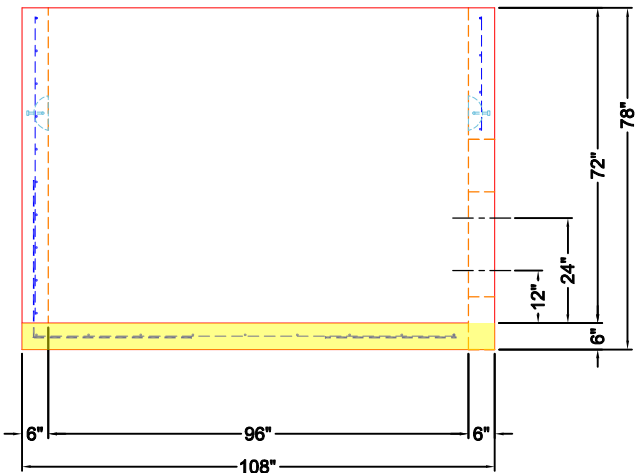

**RIGHT VIEW**

<p>PRODUCTION WORK ORDER</p>		<p>PRODUCT I.D.: CVBVF</p>	<p>DESCRIPTION: 96" X 192" X 72" TALL VAULT BASE</p>		
	<p>QUALITY CONTROL CHECKLIST</p> <p><input type="checkbox"/> ALL DIMENSIONS CORRECT.</p> <p><input type="checkbox"/> LIFTERS INSTALLED.</p> <p><input type="checkbox"/> OPENING CENTERED.</p> <p><input type="checkbox"/> REINFORCING CORRECT.</p> <p><input type="checkbox"/> SURFACE QUALITY ACCEPTABLE.</p> <p><input type="checkbox"/> EDGES CHAMFERED.</p> <p><input type="checkbox"/> ALL PATCHWORK ACCEPTABLE.</p>		<p>PRODUCT VIEW: RIGHT SIDE UP</p> <p>CUSTOMER: CONTECH ENGINEERED SOLUTIONS, LLC</p>		
			<p>PLANT: BEAVER DAM, KY.</p> <p>PROJECT: 833965 CARLOCK DEALERSHIP</p>		
			<p>WEIGHT: 32,845 LBS.</p> <p>STRUCTURE: KRACKEN KVOV0816-10</p>		
			<p>TOP SECTION JOINT: N/A</p> <p>ORDER NO: 25-3384</p>		
			<p>BASE SECTION JOINT: N/A</p> <p>PC: T. SEKULA      DRAWING: J. COPPAGE</p>		
			<p>QC CHECK INITIALS:</p> <p>DATE: 9/17/25      SCALE: NTS      PG. 1 of 1</p>		

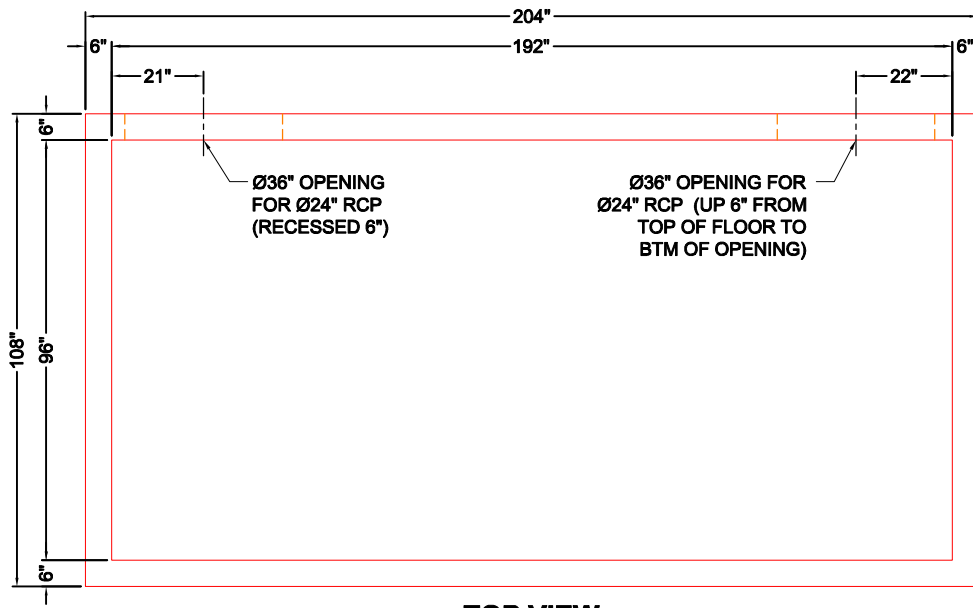

**TOP VIEW**

**GENERAL NOTES:**

1. DESIGN LOADING – AASHTO HS-20.
2. DESIGN SPECIFICATIONS – ACI 318-14.
3. CONCRETE: 5,000 PSI AT 28 DAYS. CONCRETE.
4. JOINT SEALANT SHALL CONFORM TO ASTM C-990 OR ASTM C-443.
5. REINFORCING: AS SHOWN BELOW (GRADE 60) SEE CONTECH DRAWING SF8X16 FOR ADDITIONAL INFORMATION. PER ASTM A615 (GRADE 60).
6. WEIGHTS:  
FIRST POUR = 11,093 LBS  
SECOND POUR = 21,752 LBS.  
TOTAL = 32,845 LBS
7. STRUCTURE TO HAVE INTERNALS INSTALLED BY ICAST.
8. CONTECH'S LOGO AS WELL AS THE INLETS AND OUTLETS TO BE STENCILED ONTO THE STRUCTURE.

**SECOND POUR DRAWING**

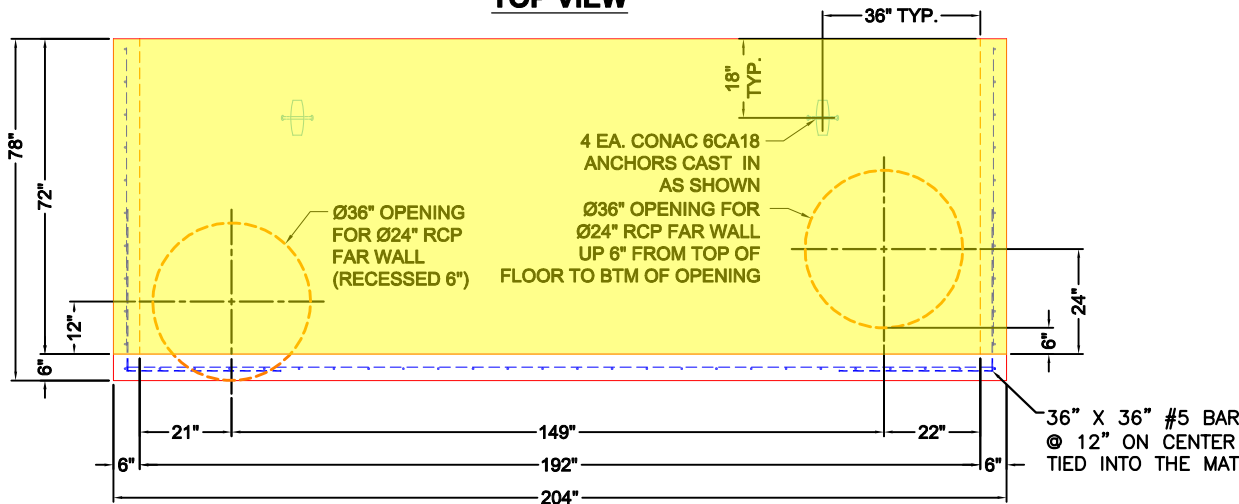

**FRONT VIEW**

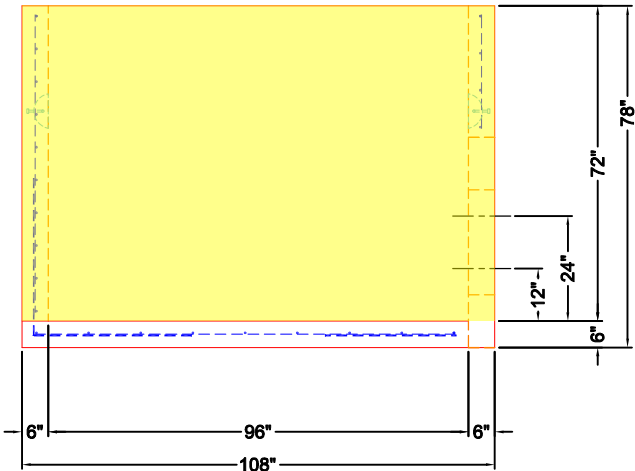

**RIGHT VIEW**

		<b>PRODUCTION WORK ORDER</b> QUALITY CONTROL CHECKLIST <input type="checkbox"/> ALL DIMENSIONS CORRECT. <input type="checkbox"/> LIFTERS INSTALLED. <input type="checkbox"/> OPENING CENTERED. <input type="checkbox"/> REINFORCING CORRECT. <input type="checkbox"/> SURFACE QUALITY ACCEPTABLE. <input type="checkbox"/> EDGES CHAMFERED. <input type="checkbox"/> ALL PATCHWORK ACCEPTABLE.	PRODUCT I.D.: CVBVF PRODUCT VIEW: RIGHT SIDE UP PLANT: BEAVER DAM, KY. WEIGHT: 32,845 LBS. TOP SECTION JOINT: N/A BASE SECTION JOINT: N/A QC CHECK INITIALS:	DESCRIPTION: 96" X 192" X 72" TALL VAULT BASE CUSTOMER: CONTECH ENGINEERED SOLUTIONS, LLC PROJECT: 833965 CARLOCK DEALERSHIP STRUCTURE: KRACKEN KVOV0816-10 ORDER NO: 25-3384 PC: T. SEKULA      DRAWING: J. COPPAGE DATE: 9/17/25      SCALE: NTS      PG. 1 of 1
---	--	--	--	--

MINIMUM LAP	
BAR SIZE	LAP
#4 [10M]	21" [535]
#5 [15M]	26" [660]
#6 [20M]	31" [790]
#7 [25M]	36" [915]
#8 [32M]	46" [1170]

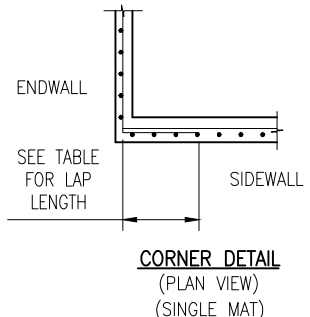
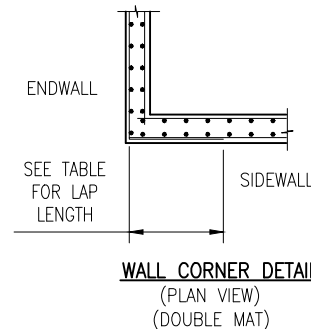
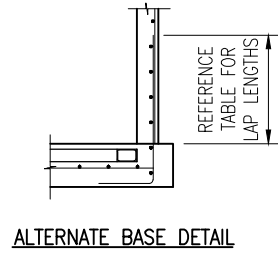

- NOTES:
- DESIGN LOAD = AASHTO HS20-44 (ONE LANE)
  - CONCRETE STRENGTH = 5000psi
  - REINFORCING STEEL - GRADE 60
  - CHART BELOW SHOWS MAXIMUM DEPTH OF FILL FOR UNIT CLASS AT VARIOUS WATER TABLE DEPTHS. DRY INDICATED W/T BELOW UNIT. FILL DEPTHS GREATER THAN 10' SHALL REQUIRE SPECIAL DESIGN.
  - PIPE OPENINGS, SIZE AND LOCATION, AS REQUIRED. PROVIDE ADDITIONAL REINFORCING EQUAL TO THE BARS INTERRUPTED, 1/2 EACH SIDE. ADD #4 DIAGONAL TRIM BARS AROUND OPENINGS.
  - IF WALL THICKNESS DIFFERS BETWEEN UNITS, ADJUST WALL THICKNESS TO MATCH THE THICKER WALL.
  - FULL HEIGHT MONO BASE UNIT, MUST HAVE TOP SLAB IN PLACE PRIOR TO BACK FILLING.
  - BAR WEIGHTS & DETAILS BASED ON VISUAL SHOWN.
  - SECONDARY CAST FLOW KIT SHALL BE IN PLACE PRIOR TO BACK FILLING.
  - THE OPENING SIZES AND LOCATIONS MAY VARY. FOR EXACT SIZES AND LOCATIONS SEE CONTECH PROJECT SPECIFIC DRAWINGS.

SECTION	0	3	6	9	DRY
FULL BASE	5.25	6.75	9.25	10.00	10.00

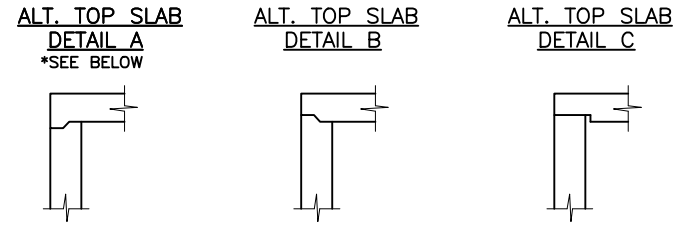

\* ALTERNATE SLAB DETAIL "A" CANNOT BE USED WITH FULL HEIGHT MONO BASE. SEE NOTE 7 ABOVE.

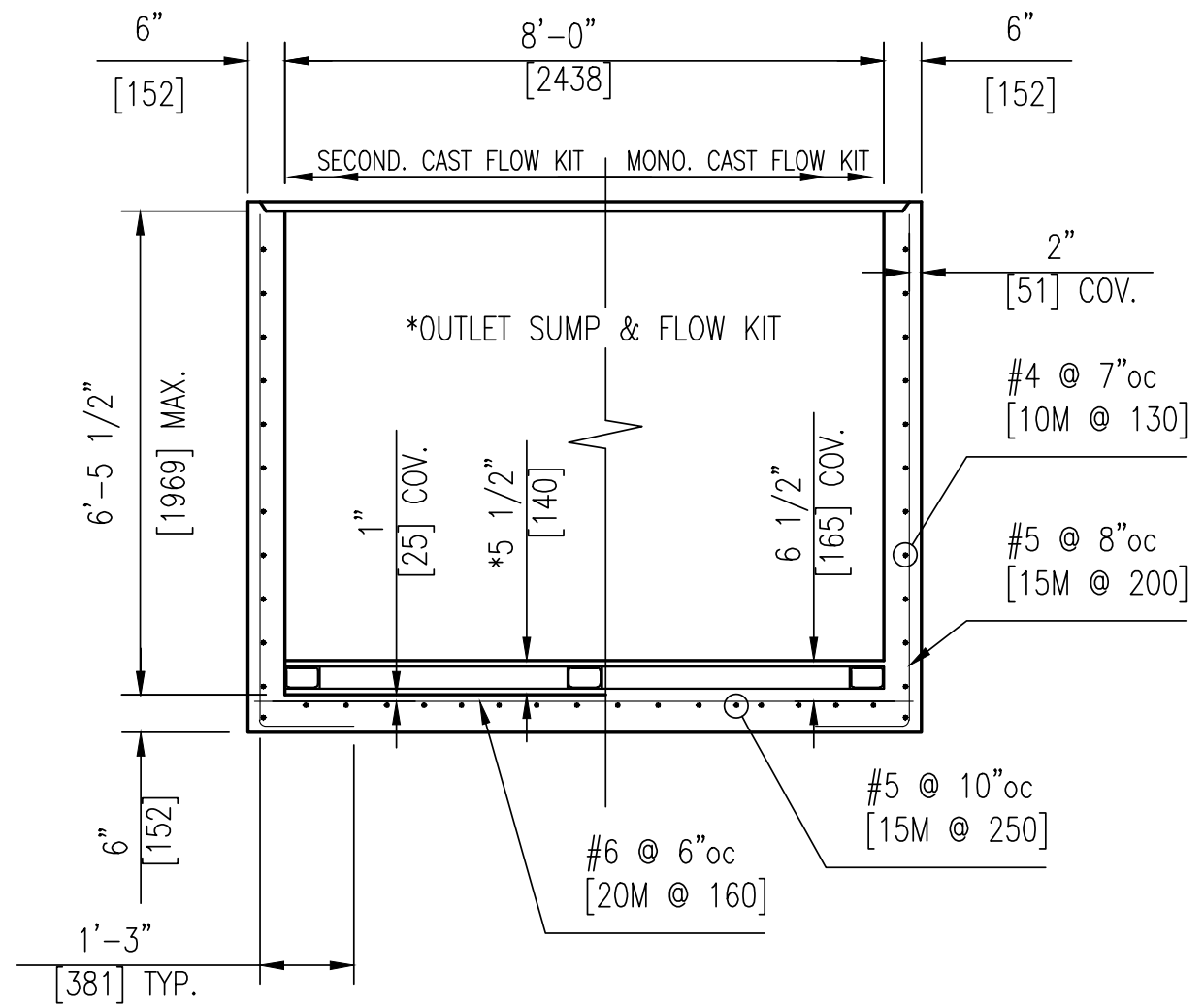

**FULL HEIGHT MONOLITHIC BASE UNIT**  
(BAR WEIGHT = 1747 LBS.)  
SEE NOTE 7

ALTERNATE WALL DESIGN (HORIZONTAL BARS TO OUTSIDE)			
WALLS	VERT.	HORIZ.	COV. TO HORIZ.
6"	#5 @ 8"	#4 @ 10"	1 1/2"

STORMFILTER 8' X 16': 800 CLASS 16'-0" L x 8'-0" W x 6'-0" I.D.

**25-3384**  
**833965 Carlock Dealership**  
**KRACKEN KVOV0816-10**



PREPARED FOR:

TITLE: STORMFILTER 8 X 16 - 800 CLASS

PROJECT: STORMFILTER

DRAWN BY: KMK

CHECKED BY: SLV

SCALE: NONE

DATE: 6/2010

JOB No: 2007.025.058

NUMBER: SF8X16

