

Job Name: 25-3353 - PORTLAND SEWER IMPROVEMENTS

Job Location: Portland, TN 37148

Contractor: Core & Main LP (Nashville)

PC: E. Bradley

TECH: J. Horsley - F

Plant: 100



Structure ID: **SSMH B-2**

Spec: Sanitary

Type: SAN.MH w/ConBlock-CDA Red

Size: 48"

Rim: 777.33'

Invert: 771.33'

Rim to Invert: 6'

Sump: 2"

Floor (Top): 771.163'

Floor Height: 6"

Floor (Bot): 770.663'

Overall Height: 6.5'

Slack: 2"

Structure Notes:

1. PER ASTM C478 SPECIFICATIONS.
2. CONCRETE = 4,000 PSI AT 28 DAYS.
3. ADMIXTURE = CONBLOCK CDA RED.
4. CASTING BY I-CAST (JBS 1155 F/C "SANITARY").

REINFORCING PER ASTM A615 (GRADE 60).

- CONE (As .12)
- RISER/WALLS (As .12)
- FLOOR (As .31) #5 BARS AT 12" C.C.E.W.

STRUCTURE SUMMARY:

| | |
|--|----------------|
| P3) 24" - CASTING HEIGHT - 6" | 0 lb |
| P2) 48" - ECC CONE w/ 24" HOLE, w/ConBlock-CDA Red F/G - 36" | 2251 lb |
| P1) 48" - MH BASE w/ConBlock-CDA Red T/n - 30" | 3330 lb |
| 1) JOINT WRAP - 0.065"x6"x50' CONSEAL CS212 | 0 lb |
| 1) JOINT WRAP PRIMER - CONSEAL CS-75 (1 gal.) | 0 lb |
| 1) 48" - MH INVERT CHANNEL - FULL HEIGHT | 1440 lb |
| 1) ADMIXTURE CONBLOCK CDA RED | 0 lb |
| 1) CASTING - JBS 1155 F/C SANITARY | 250 lb |
| 1) 48" - Conseal CS-102 1.00" (Double) | 0 lb |
| 2) PSX - 12-08 NYLO | 16 lb |
| 5) MH Step ML-10-TDS-NCR - 10" | 0 lb |
| Structure Total: | 7287 lb |

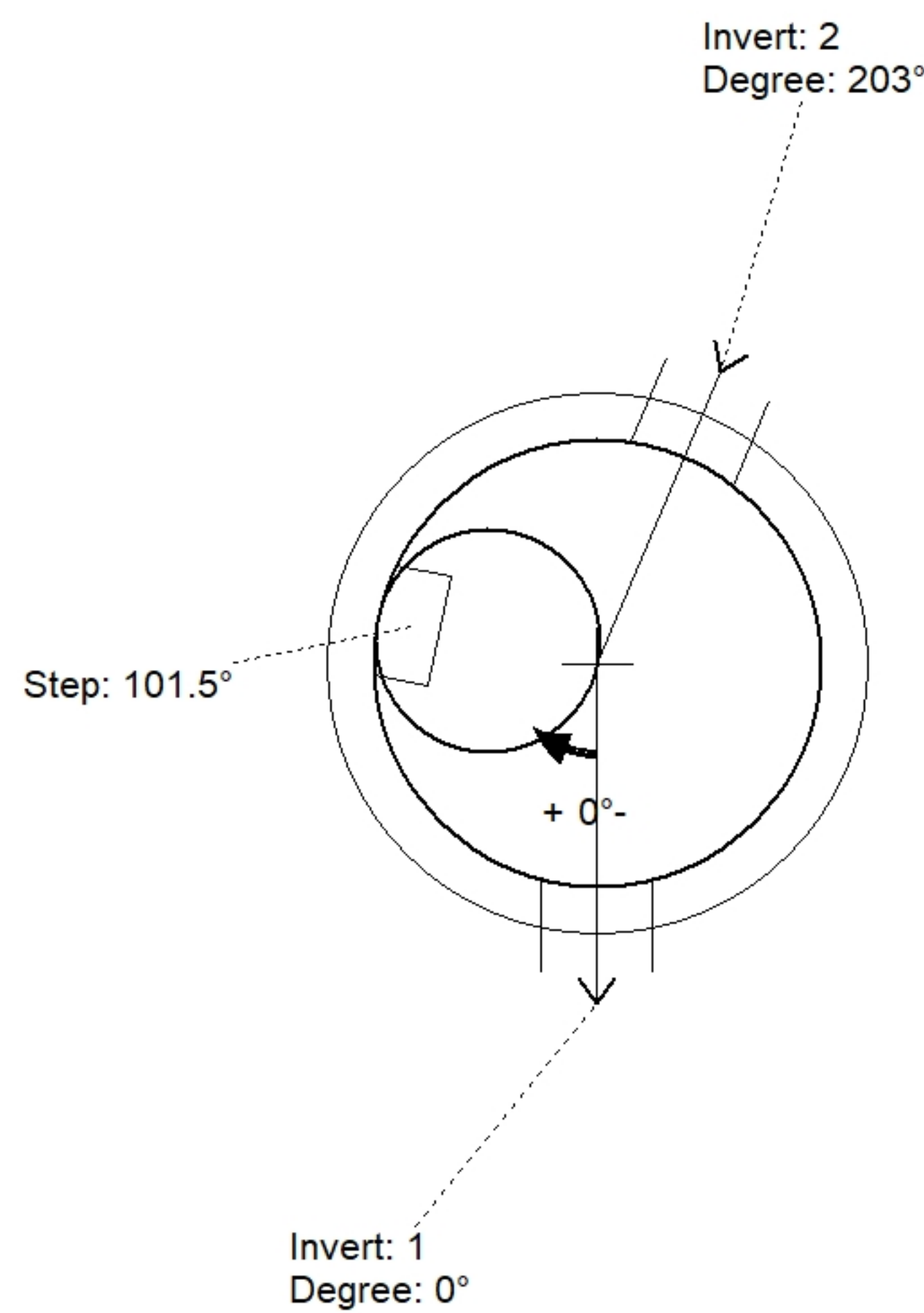

| Position | Elev | Angle | Pipe | Pipe OD | Hole | Connector | Up () | Ref |
|----------|---------|-------|--------------|---------|------|----------------|--------|-----|
| Rim | 777.33' | | | | | | | |
| Reducer | | | | | | | | |
| Invert 1 | 771.33' | 0° | 8" PVC SDR26 | 8.5" | 12" | PSX 12-08 NYLO | 0" | P1 |
| Invert 2 | 771.53' | 203° | 8" PVC SDR26 | 8.5" | 12" | PSX 12-08 NYLO | 2.375" | P1 |
| Invert 3 | | | | | | | | |
| Invert 4 | | | | | | | | |
| Invert 5 | | | | | | | | |
| Invert 6 | | | | | | | | |
| Invert 7 | | | | | | | | |
| Invert 8 | | | | | | | | |

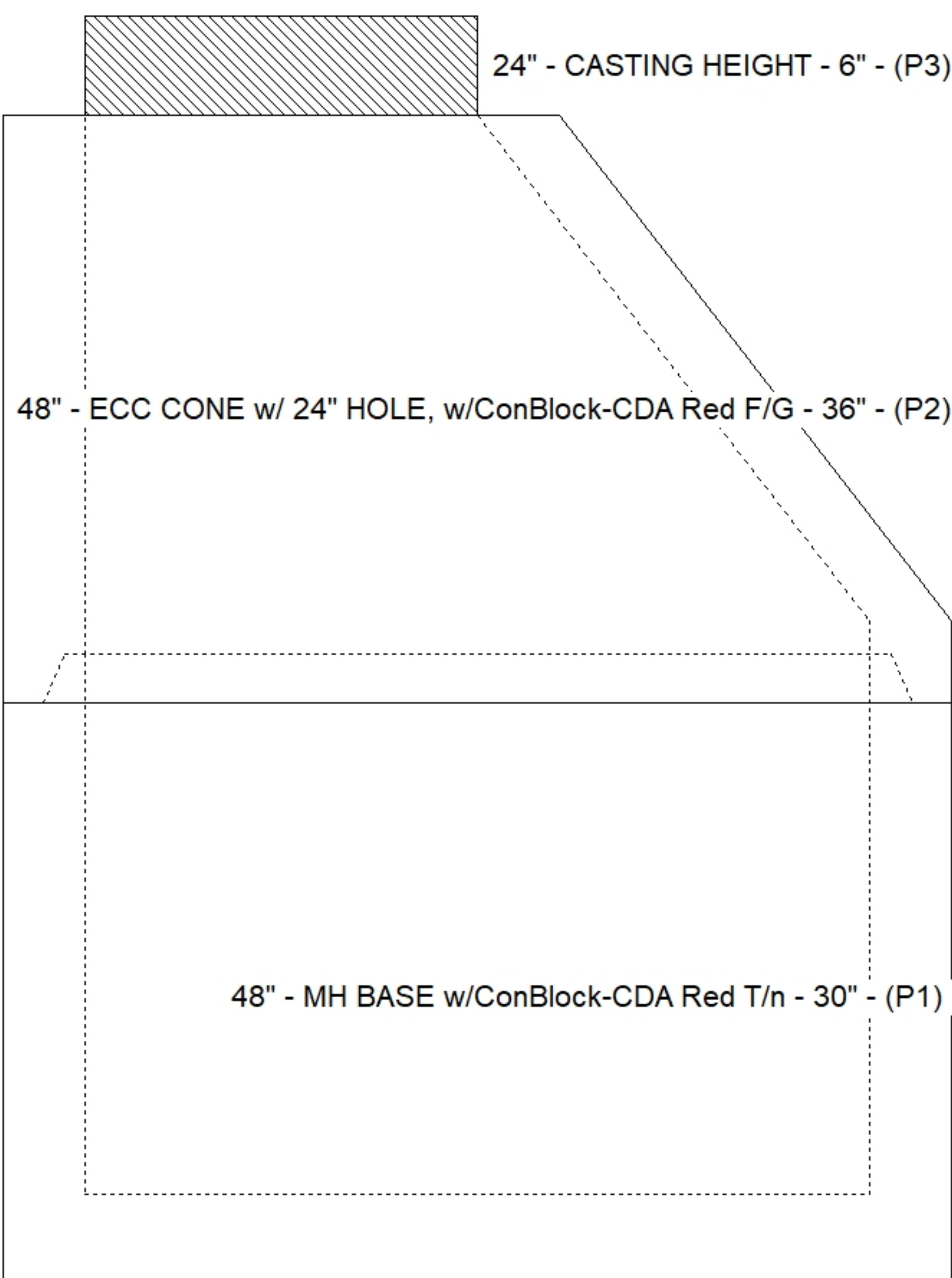

Cast (Int. Dim.) - Interior Dimensions

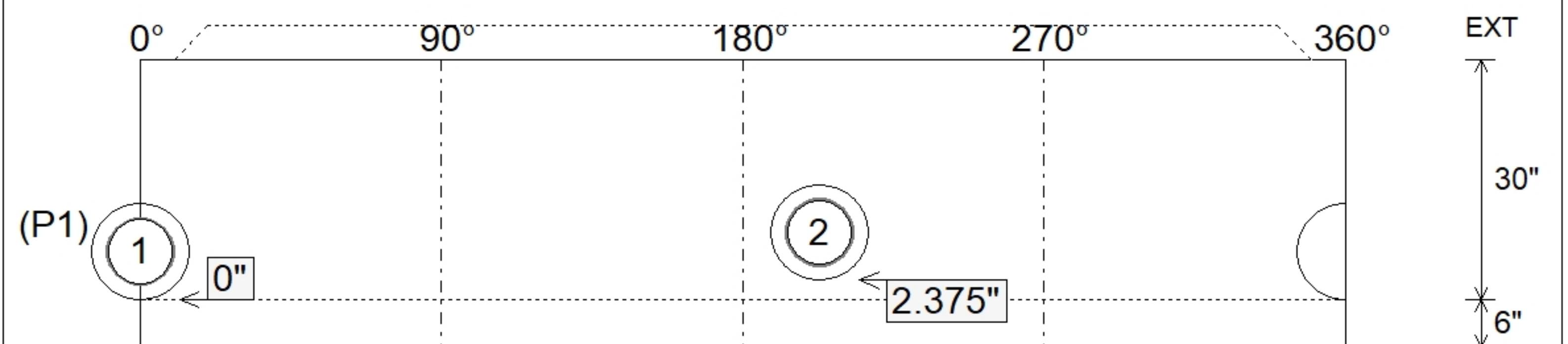

Submittal Drawing
11/13/2025 8:58:44 AM

SUBMITTAL
APPROVED BY: