

Job Name: 25-3353 - PORTLAND SEWER IMPROVEMENTS	Plant: 100	Tech: J. Horsley - F
Job Location: Portland, TN 37148	11/13/2025 8:59:23 AM	PC: E. Bradley
Contractor: Core & Main LP (Nashville)		

Structure ID: SSMH 316

P1 MH048BA24CDARED

MH BASE w/ConBlock-CDA Red T/n

- P3) 24" - CASTING HEIGHT - 6"
- P2) 48" - ECC CONE w/ 24" HOLE, w/ConBlock-CDA Red F/G - 30"
- P1) 48" - MH BASE w/ConBlock-CDA Red T/n - 24"
- 1) JOINT WRAP - 0.065"x6"x50' CONSEAL CS212
- 1) JOINT WRAP PRIMER - CONSEAL CS-75 (1 gal.)
- 1) 48" - MH INVERT CHANNEL - FULL HEIGHT
- 1) ADMIXTURE CONBLOCK CDA RED
- 1) CASTING - JBS 1155 F/C SANITARY
- 1) 48" - Conseal CS-102 1.00" (Double)
- 1) PSX - 12-08 NYLO
- 5) MH Step ML-10-TDS-NCR - 10"

0 lb
1961 lb
2959 lb
0 lb
0 lb
1440 lb
0 lb
250 lb
0 lb
8 lb
0 lb

Structure Total: 6618 lb

Structure Notes:

1. PER ASTM C478 SPECIFICATIONS.
2. CONCRETE = 4,000 PSI AT 28 DAYS.
3. ADMIXTURE = CONBLOCK CDA RED.
4. CASTING BY I-CAST (JBS 1155 F/C "SANITARY").

REINFORCING PER ASTM A615 (GRADE 60).

- CONE (As .12)
- RISER/WALLS (As .12)
- FLOOR (As .31) #5 BARS AT 12" C.C.E.W.

Rim: 792' Rim to Invert: 5' Slack: 2" Sump: 2" Step Position: 180°

Position	Elev	Angle	Ext. (cw)	Pipe	Pipe OD	Connector	Hole	Horz Size	Up ()	Offset
Invert 1	787'	0°	0"	8" PVC SDR26	8.5"	PSX 12-08 NYLO	12"	12.129"	0"	0"
Invert 2										
Invert 3										
Invert 4										
Invert 5										
Invert 6										
Invert 7										
Invert 8										

RIGHT-SIDE UP VIEW (int. dimensions)

UPSIDE-DOWN VIEW (int. dimensions)

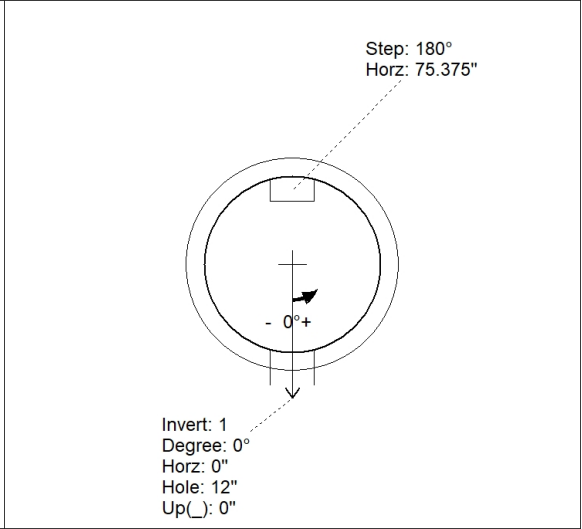
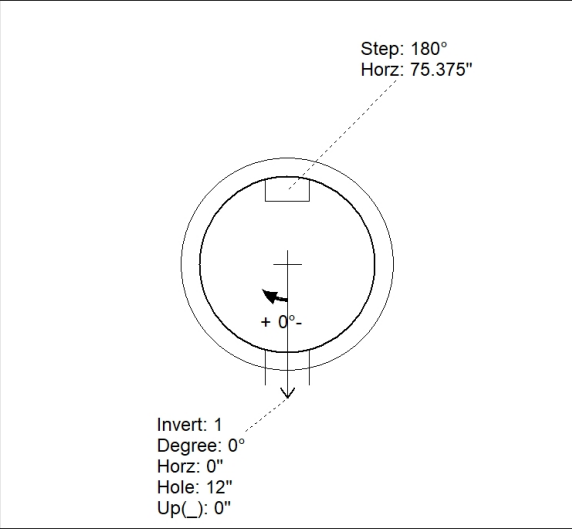
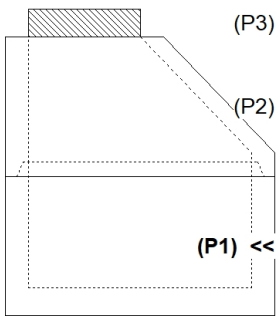

INSIDE WALL DIMENSIONS

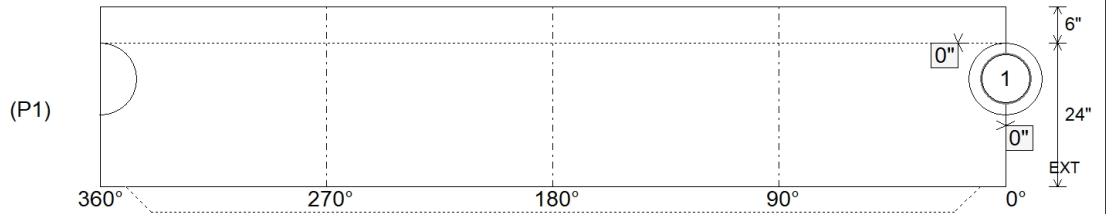

Coating (Int):	Seam Up: Tongue	Wall Thickness: 5"	Height (Int): 24"	Weight (Net): 2959 lb
Coating (Ext):	Seam Dn: n/a	Floor Height: 6"	Height (Ext): 30"	Volume (Net): 0.76cu.yd

Job Name: 25-3353 - PORTLAND SEWER IMPROVEMENTS	Plant: 100	Tech: J. Horsley - F
Job Location: Portland, TN 37148	11/13/2025 8:59:23 AM	PC: E. Bradley
Contractor: Core & Main LP (Nashville)		

Structure ID: SSMH 316

P1A MH048BA24CDARED

MH BASE w/ConBlock-CDA Red T/n

- P3) 24" - CASTING HEIGHT - 6"
- P2) 48" - ECC CONE w/ 24" HOLE, w/ConBlock-CDA Red F/G - 30"
- P1) 48" - MH BASE w/ConBlock-CDA Red T/n - 24"
- 1) JOINT WRAP - 0.065"x6"x50' CONSEAL CS212
- 1) JOINT WRAP PRIMER - CONSEAL CS-75 (1 gal.)
- 1) 48" - MH INVERT CHANNEL - FULL HEIGHT
- 1) ADMIXTURE CONBLOCK CDA RED
- 1) CASTING - JBS 1155 F/C SANITARY
- 1) 48" - Conseal CS-102 1.00" (Double)
- 1) PSX - 12-08 NYLO
- 5) MH Step ML-10-TDS-NCR - 10"

0 lb
1961 lb
2959 lb
0 lb
0 lb
1440 lb
0 lb
250 lb
0 lb
8 lb
0 lb

Structure Total: 6618 lb

Structure Notes:

1. PER ASTM C478 SPECIFICATIONS.
2. CONCRETE = 4,000 PSI AT 28 DAYS.
3. ADMIXTURE = CONBLOCK CDA RED.
4. CASTING BY I-CAST (JBS 1155 F/C "SANITARY").

REINFORCING PER ASTM A615 (GRADE 60).

- CONE (As .12)
- RISER/WALLS (As .12)
- FLOOR (As .31) #5 BARS AT 12" C.C.E.W.

Rim: 792' Rim to Invert: 5' Slack: 2" Sump: 2" Step Position: 180°

Position	Elev	Angle	Ext. (cw)	Pipe	Pipe OD	Connector	Hole	Horz Size	Up ()	Offset
Invert 1	787'	0°	0"	8" PVC SDR26	8.5"	PSX 12-08 NYLO	12"	12.129"	0"	0"
Invert 2										
Invert 3										
Invert 4										
Invert 5										
Invert 6										
Invert 7										
Invert 8										

RIGHT-SIDE UP VIEW (int. dimensions)

UPSIDE-DOWN VIEW (int. dimensions)

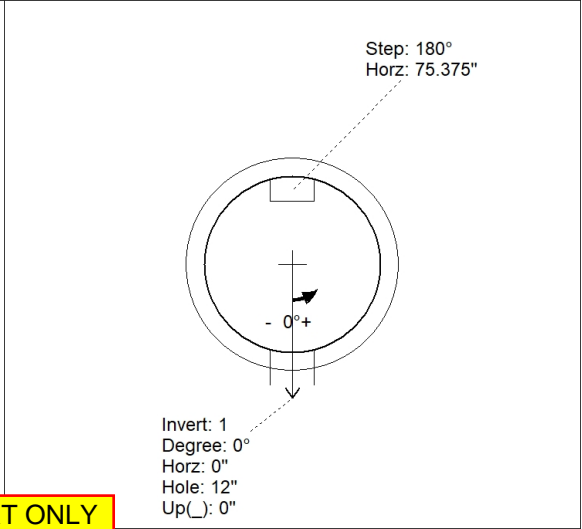
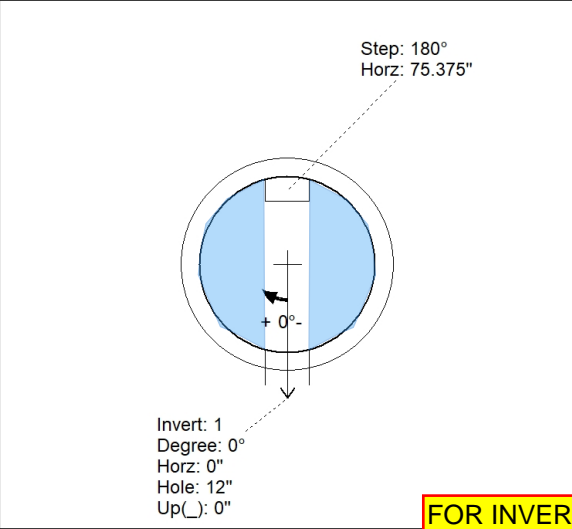
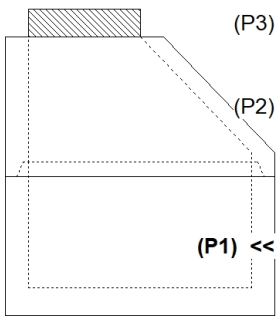

INSIDE WALL DIMENSIONS

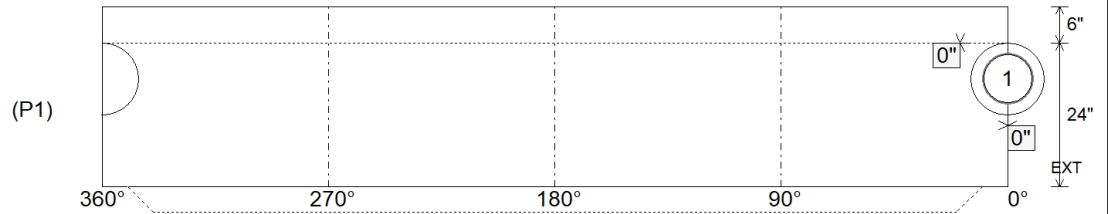

Coating (Int):	Seam Up: Tongue	Wall Thickness: 5"	Height (Int): 24"	Weight (Net): 2959 lb
Coating (Ext):	Seam Dn: n/a	Floor Height: 6"	Height (Ext): 30"	Volume (Net): 0.76cu.yd