

Job Name: 25-3353 - PORTLAND SEWER IMPROVEMENTS	Plant: 100	Tech: J. Horsley - F
Job Location: Portland, TN 37148	11/13/2025 8:59:41 AM	PC: E. Bradley
Contractor: Core & Main LP (Nashville)		

**Structure ID: SSMH 172**

**P2 MH048RS36CDARED**

**MH RISER w/ConBlock-CDA Red T/G**

P4) 24" - CASTING HEIGHT - 6"	0 lb
P3) 48" - ECC CONE w/ 24" HOLE, w/ConBlock-CDA Red F/G - 30"	1961 lb
P2) 48" - MH RISER w/ConBlock-CDA Red T/G - 36"	2515 lb
P1) 48" - MH BASE w/ConBlock-CDA Red T/n - 24"	2959 lb
1) JOINT WRAP - 0.065"x6"x50' CONSEAL CS212	0 lb
1) JOINT WRAP PRIMER - CONSEAL CS-75 (1 gal.)	0 lb
1) 48" - MH INVERT CHANNEL - FULL HEIGHT	1440 lb
1) ADMIXTURE CONBLOCK CDA RED	0 lb
1) CASTING - JBS 1155 F/C SANITARY	250 lb
2) 48" - Conseal CS-102 1.00" (Double)	0 lb
1) PSX - 12-08 NYLO	8 lb
8) MH Step ML-10-TDS-NCR - 10"	0 lb
<b>Structure Total:</b>	<b>9133 lb</b>

**Structure Notes:**  
 1. PER ASTM C478 SPECIFICATIONS.  
 2. CONCRETE = 4,000 PSI AT 28 DAYS.  
 3. ADMIXTURE = CONBLOCK CDA RED.  
 4. CASTING BY I-CAST (JBS 1155 F/C "SANITARY").

REINFORCING PER ASTM A615 (GRADE 60).  
 - CONE (As .12)  
 - RISER/WALLS (As .12)  
 - FLOOR (As .31) #5 BARS AT 12" C.C.E.W.

Rim: 818' Rim to Invert: 8' Slack: 2" Sump: 2" Step Position: 180°

Position	Elev	Angle	Ext. (cw)	Pipe	Pipe OD	Connector	Hole	Horz Size	Up (L)	Offset
Invert 1										
Invert 2										
Invert 3										
Invert 4										
Invert 5										
Invert 6										
Invert 7										
Invert 8										

**RIGHT-SIDE UP VIEW (int. dimensions)**

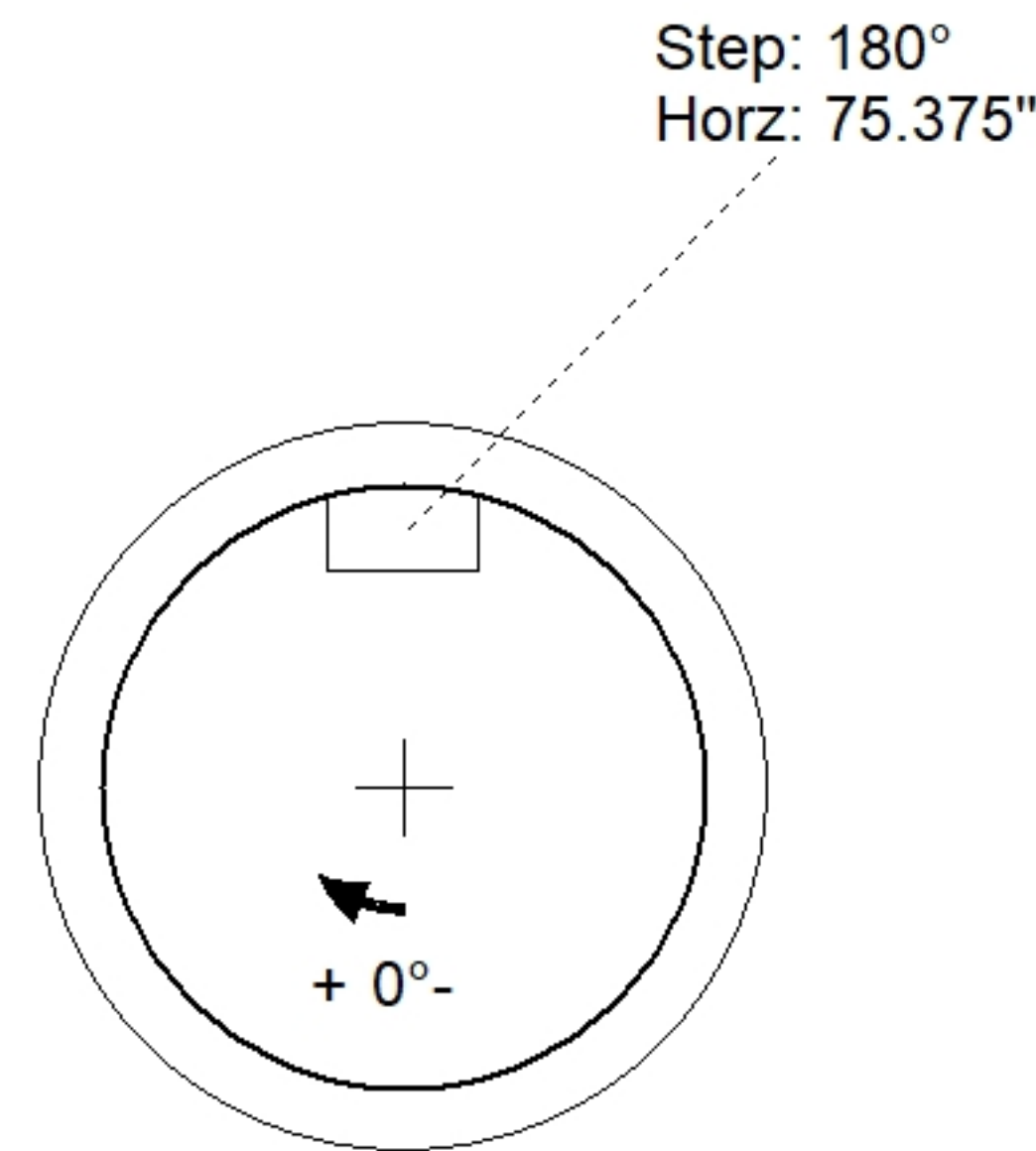
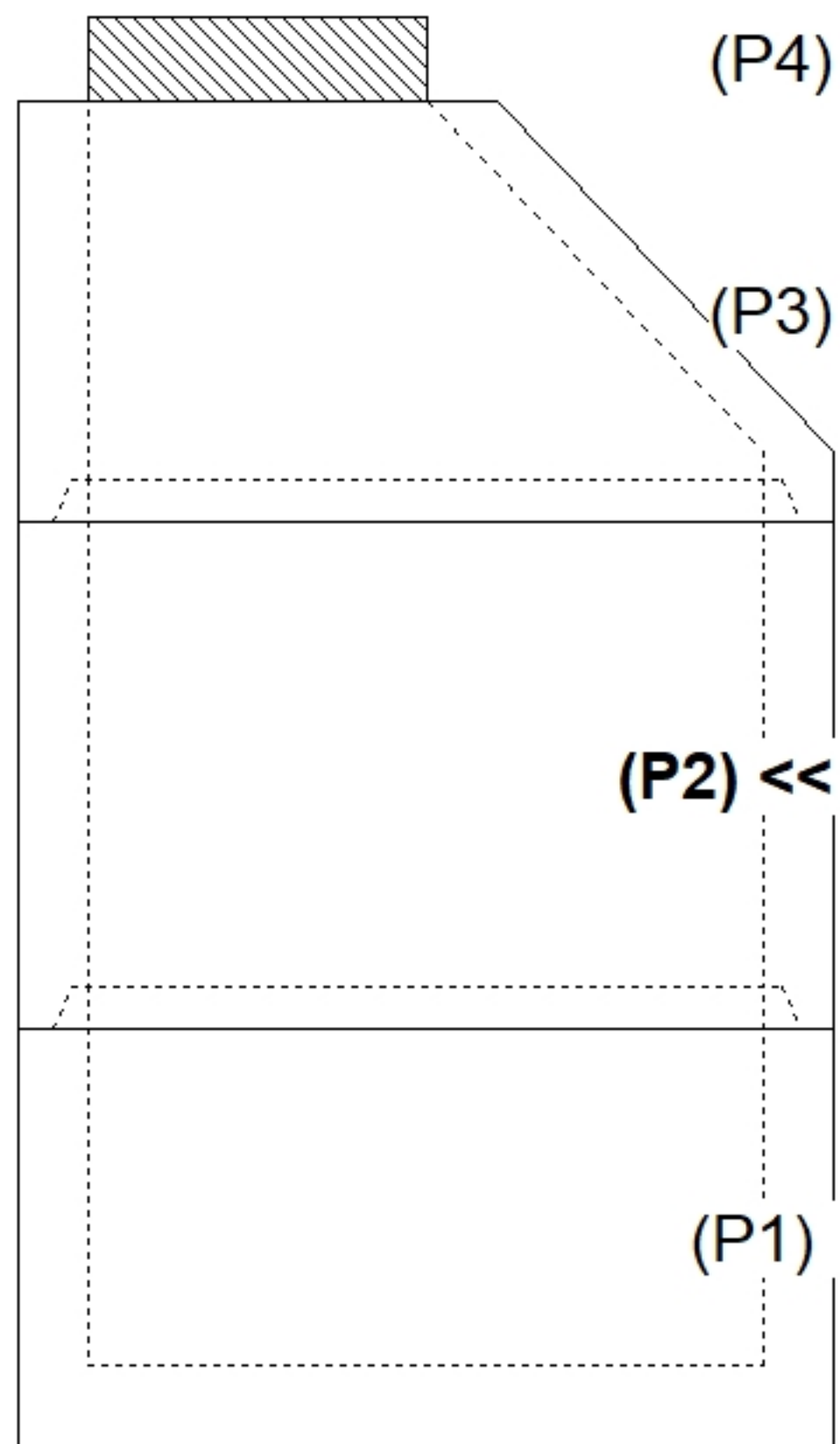

**INSIDE WALL DIMENSIONS**

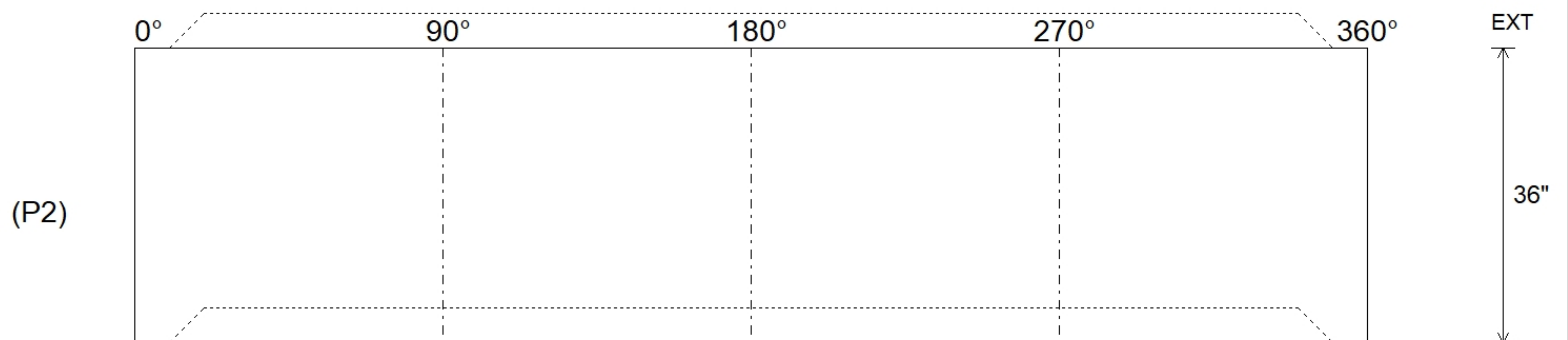

Coating (Int):	Seam Up: Tongue	Wall Thickness: 5"	Height (Int): 36"	Weight (Net): 2515 lb
Coating (Ext):	Seam Dn: Groove	Floor Height: 0"	Height (Ext): 36"	Volume (Net): 0.64cu.yd