

Job Name: 25-3347 - EARLE CREEK TRIBUTARY CULVERT
 Job Location: ANTON, KY
 Contractor: Kmac Contracting, LLC

Plant: Beaver Dam

Tech: J. Coppage

12/22/2025 11:42:04 AM

PC: T. Lewis



Structure ID: BOX CUVERT 2

P3 BC096072-08WLF-9HC

BOX CULVERT (08W/08F/08T)

P8) 96" x 72" - BOX CULVERT (08W/08F/08T) - 69"	17992 lb
P7) 96" x 72" - BOX CULVERT (08W/08F/08T) - 69"	17992 lb
P6) 96" x 72" - BOX CULVERT (08W/08F/08T) - 69"	17992 lb
P5) 96" x 72" - BOX CULVERT (08W/08F/08T) - 69"	17992 lb
P4) 96" x 72" - BOX CULVERT (08W/08F/08T) - 69"	17992 lb
P3) 96" x 72" - BOX CULVERT (08W/08F/08T) - 69"	17992 lb
P2) 96" x 72" - BOX CULVERT (08W/08F/08T) - 69"	17992 lb
P1) 96" x 72" - BOX CULVERT (08W/08F/08T) - 54"	14077 lb
1) Conseal CS-102 1.00" (Single)	0 lb
1) JOINT WRAP - 0.065"x12"x50' CONSEAL CS212	0 lb
1) JOINT WRAP PRIMER - CONSEAL CS-75 (1 gal.)	0 lb
Structure Total:	140021 lb

Rim: 45' Rim to Invert: 0' Slack: 3" Sump: 0" Step Position:

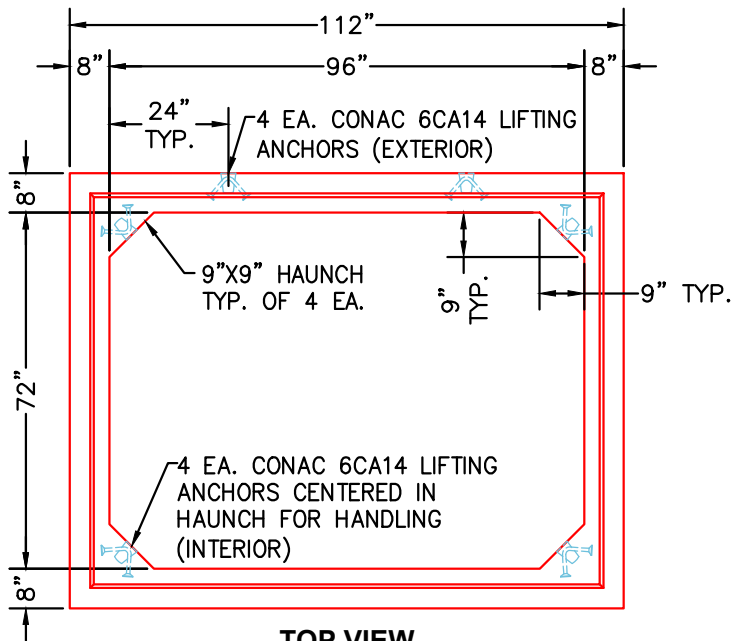

NOTES:

1. BOX CULVERT IS DESIGNED PER SECTION 605 OF THE KYTC STANDARD SPECIFICATION FOR ROAD & BRIDGE CONSTRUCTION.
2. LOAD REQUIREMENTS PER KY-HL93 (KY TABLE 1)
3. REINFORCEMENT SHALL CONFORM TO ASTM A615, SEE ATTACHED REINFORCING DESIGN KYTC TABLE 1.
4. CONCRETE: 5,000 PSI AT 28 DAYS.
5. BOX CULVERT TO BE SEALED WITH CONCRETE SEALANTS, INC. CS-102 ROLL BUTYL MASTIC & CS-212 12" WRAP. (SUPPLIED BY ICAST).
6. WEIGHT: 17,992 LBS.

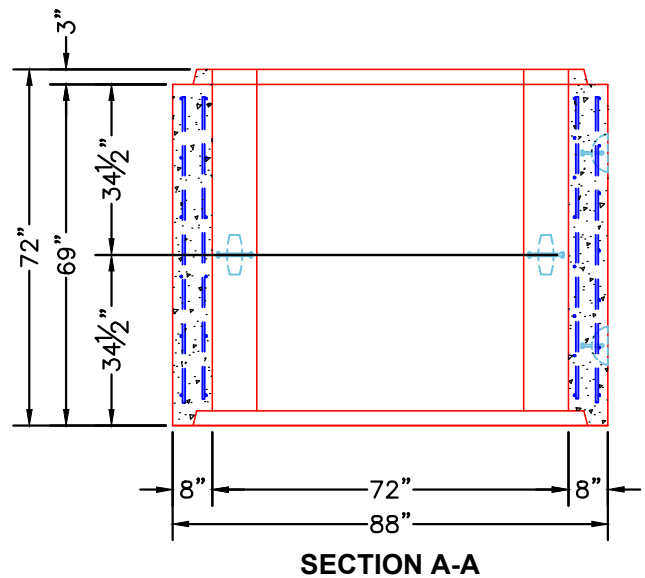
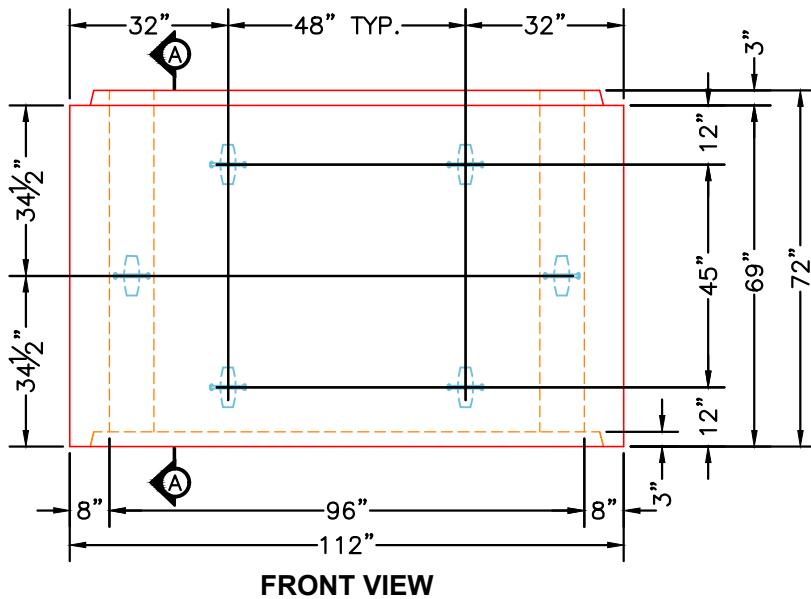
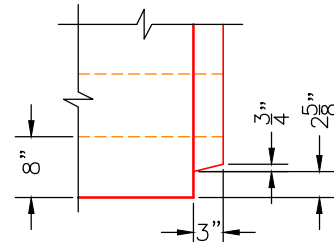

Coating (Int): Coating (Ext):	Seam Up: Tongue Seam Dn: Groove	Wall Thickness: 8" Floor Height: 0"	Height (Int): 69" Height (Ext): 69"	Weight (Net): 17992 lb Volume (Net): 4.6cu.yd
----------------------------------	------------------------------------	--	--	--

25-3347
EARLE CREEK TRIBUTARY CULVERT
REINFORCEMENT INFORMATION



TRANSPORTATION CABINET

Frankfort, Kentucky 40622
www.transportation.ky.gov/

Steven L. Beshear
Governor

Michael W. Hancock, P.E.
Secretary

MEMORANDUM

TO: Allen Myers, P.E., Division of Materials
Nancy Albright, P.E., Division of Maintenance
Steven D. Criswell, P.E., Division of Construction
Directors

ATTN: Wesley Glass, P.E., Division of Materials
Nasby Stroop, P.E., Division of Construction

FROM: Lizabeth Likins, E.I.T., Division of Construction 

DATE: August 27th, 2012

SUBJECT: Kentucky Table 1, Precast Box Culvert Steel Requirements

In order to expedite the approval of precast box culvert designs and guarantee the quality design equivalent to a KYHL-93 cast-in-place culvert design, Kentucky Table 1 may be used. The table provides the minimum required steel area for each designated location in precast box culverts. Fabrication may begin on designs meeting the requirements of Kentucky Table 1 without approved shop drawings at the risk and expense of the fabricator.

For box culverts with fill heights between the values listed in the table, the more conservative steel values from either above or below the specified fill height will govern. This is not an exhaustive listing of box culvert sizes or fill heights. For fill heights exceeding Kentucky Table 1 and/or design load requirements other than KYHL-93, a design stamped by a Professional Engineer, licensed in the Commonwealth of Kentucky, or a design verified by the inputs of FHWA BOXCAR version 3.1 will be required. The default design values are listed in the attachment.

Equivalent steel areas are in units of square inches per foot of length. Lengths and spacing of reinforcements listed are in units of inches. The fabricator is required to advise the Division of Materials prior to initiation of fabrication. The following KY Table 1 will replace all previous versions of KY Table 3 and addendums.

Attachments



An Equal Opportunity Employer M/F/D

25-3347 EARLE CREEK TRIBUTARY CULVERT REINFORCEMENT INFORMATION

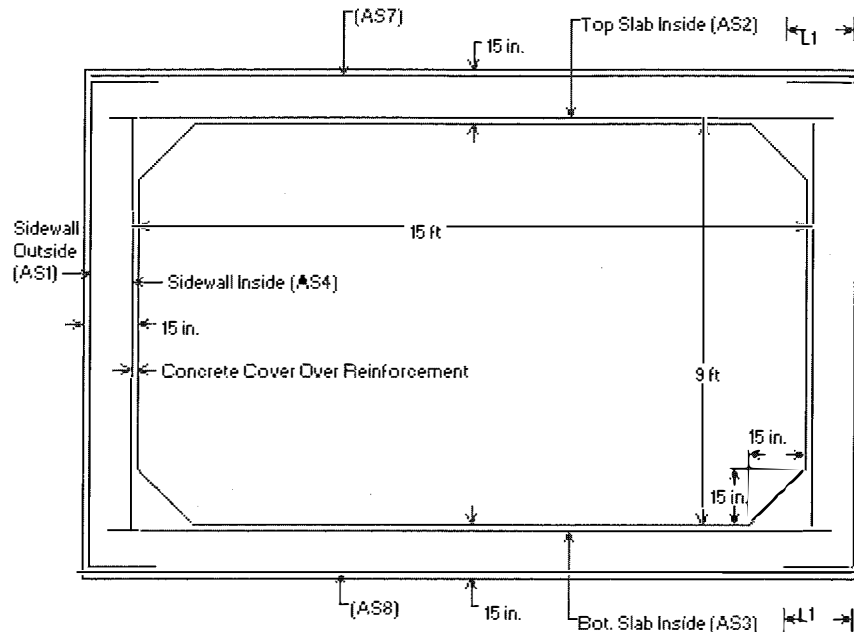

- * $\langle L1 \rangle$ is Splice Length
- * (AS7) is Top Slab Outside
- * (AS8) is Bottom Slab Outside
- * See Box Culvert Design Summary Sheet for transverse and distribution reinforcement, as required.
- * For sidewall thicknesses of 6 in. and above, extend AS2 and AS3 a min. of 4 in. beyond the inside face of the sidewall. For thicknesses less than 6 in., extend AS2 and AS3 at least to within 1-1/2 in. of the outside face of the sidewall.

Notes:

- 1) Other reinforcement schemes that provide the required reinforcement areas at all locations identified in the program output are acceptable.
- 2) Longitudinal reinforcement is not shown for clarity, see AASHTO M259 for longitudinal reinforcement and for additional requirements.

KY Table 1

Precast Culvert KYHL-93 Design Table

	Design Earth Cover, ft	As1	As2	As3	As4	As7	As8	As5	As6
8x6x8	0<2	0.267	0.536	0.382	0.192	0.192	0.192	0.192	0.192
	2<3	0.266	0.458	0.382	0.192	0.192	0.192	0.192	0.192
	3-5	0.237	0.392	0.359	0.192	0.192	0.192		
	10	0.244	0.365	0.38	0.192	0.192	0.192		
	15	0.321	0.489	0.505	0.192	0.192	0.192		
	20	0.408	0.627	0.644	0.192	0.192	0.192		
	25	0.502	0.774	0.791	0.192	0.192	0.192		
	30	0.602	0.928	0.946	0.192	0.192	0.192		
	35	0.708	1.089	1.108	0.192	0.192	0.192		

**25-3347
EARLE CREEK TRIBUTARY CULVERT
REINFORCEMENT INFORMATION**