

Job Name: 25-3333 Canon Court  
 Job Location: Dawson Springs, KY  
 Contractor: J & J Excavating

Plant: 100

11/19/2025 6:26:04 PM

Tech: J. Horsley -F

PC: A. Chambers



**Structure ID: SSMH 1-4**

**P1 MH048BA30**

**MH BASE T/n**

- P3) 24" - CASTING HEIGHT - 7"
- P2) 48" - ECC CONE w/ 24" HOLE F/G - 24"
- P1) 48" - MH BASE T/n - 30"
- 1) 48" - MH INVERT CHANNEL - FULL HEIGHT
- 1) JOINT WRAP - 0.065"x6"x50' CONSEAL CS212
- 1) JOINT WRAP PRIMER - CONSEAL CS-75 (1 gal.)
- 1) CASTING - HOE MC-375 F/C Sanitary
- 1) 48" - Conseal CS-102 1.00" (Double)
- 3) PSX - 12-08 NYLO
- 4) MH Step ML-10-TDS-NCR - 10"

0 lb  
 1550 lb  
 3282 lb  
 1440 lb  
 0 lb  
 0 lb  
 271 lb  
 0 lb  
 24 lb  
 0 lb  
 -----  
 Structure Total: 6567 lb

**Structure Notes:**  
 1. PER ASTM C478 SPECIFICATIONS.  
 2. CONCRETE = 4,000 PSI AT 28 DAYS.  
 3. CASTING BY ICAST (HOE MC-375 "SANITARY" F/C).  
  
 REINFORCING PER ASTM A615 (GRADE 60).  
 - CONE (As .12)  
 - RISER/WALLS (As .12)  
 - FLOOR (As .31) #5 BARS AT 12" C.C.E.W.

Rim: 407.59'    Rim to Invert: 5'    Slack: 1"    Sump: 2"    Step Position: 0°

Position	Elev	Angle	Ext. (cw)	Pipe	Pipe OD	Connector	Hole	Horz Size	Up ( )	Offset
Invert 1	402.59'	0°	0"	8" PVC SDR26	8.5"	PSX 12-08 NYLO	12"	12.129"	0"	0"
Invert 2	403.71'	90°	45.5"	8" PVC SDR26	8.5"	PSX 12-08 NYLO	12"	12.129"	13.5"	0"
Invert 3	402.69'	180°	91.125"	8" PVC SDR26	8.5"	PSX 12-08 NYLO	12"	12.129"	1.25"	0"
Invert 4										
Invert 5										
Invert 6										
Invert 7										
Invert 8										

RIGHT-SIDE UP VIEW (int. dimensions)

UPSIDE-DOWN VIEW (int. dimensions)

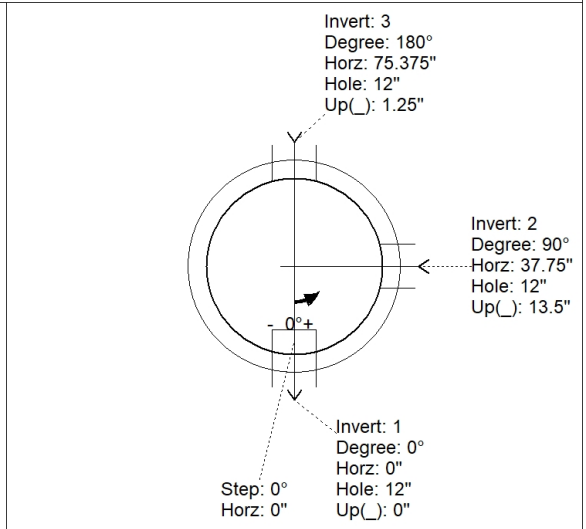
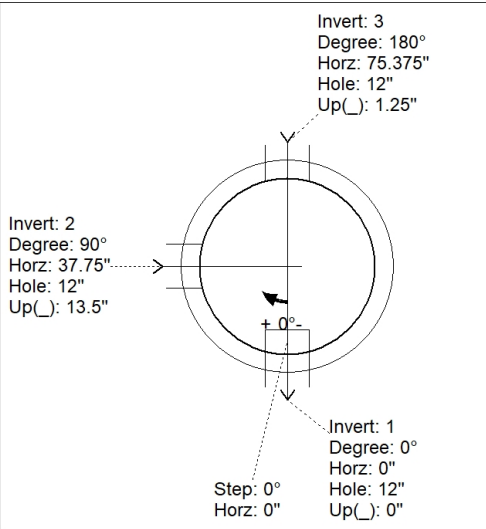
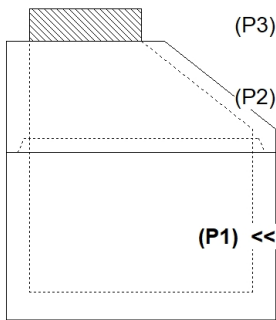

INSIDE WALL DIMENSIONS

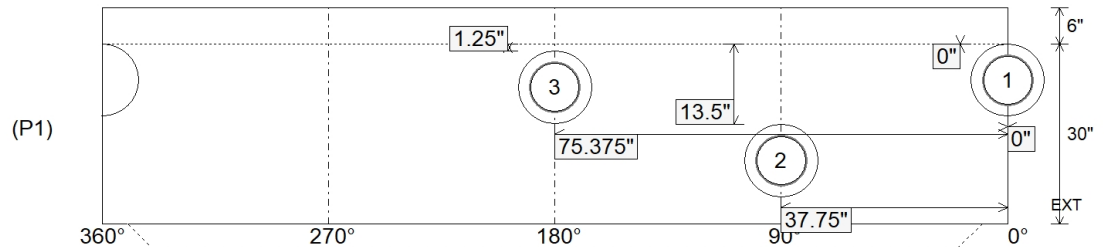

Coating (Int):  
 Coating (Ext):

Seam Up: Tongue  
 Seam Dn: n/a

Wall Thickness: 5"  
 Floor Height: 6"

Height (Int): 30"  
 Height (Ext): 36"

Weight (Net): 3282 lb  
 Volume (Net): 0.84cu.yd

Job Name: 25-3333 Canon Court  
 Job Location: Dawson Springs, KY  
 Contractor: J & J Excavating

Plant: 100

11/19/2025 6:26:04 PM

Tech: J. Horsley -F

PC: A. Chambers



**Structure ID: SSMH 1-4**

**P1A MH048BA30**

**MH BASE T/n**

- P3) 24" - CASTING HEIGHT - 7"
- P2) 48" - ECC CONE w/ 24" HOLE F/G - 24"
- P1) 48" - MH BASE T/n - 30"
- 1) 48" - MH INVERT CHANNEL - FULL HEIGHT
- 1) JOINT WRAP - 0.065"x6"x50' CONSEAL CS212
- 1) JOINT WRAP PRIMER - CONSEAL CS-75 (1 gal.)
- 1) CASTING - HOE MC-375 F/C Sanitary
- 1) 48" - Conseal CS-102 1.00" (Double)
- 3) PSX - 12-08 NYLO
- 4) MH Step ML-10-TDS-NCR - 10"

0 lb  
 1550 lb  
 3282 lb  
 1440 lb  
 0 lb  
 0 lb  
 271 lb  
 0 lb  
 24 lb  
 0 lb  
 -----  
 Structure Total: 6567 lb

**Structure Notes:**  
 1. PER ASTM C478 SPECIFICATIONS.  
 2. CONCRETE = 4,000 PSI AT 28 DAYS.  
 3. CASTING BY ICAST (HOE MC-375 "SANITARY" F/C).  
  
 REINFORCING PER ASTM A615 (GRADE 60).  
 - CONE (As .12)  
 - RISER/WALLS (As .12)  
 - FLOOR (As .31) #5 BARS AT 12" C.C.E.W.

Rim: 407.59' Rim to Invert: 5' Slack: 1" Sump: 2" Step Position: 0°

Position	Elev	Angle	Ext. (cw)	Pipe	Pipe OD	Connector	Hole	Horz Size	Up ( )	Offset
Invert 1	402.59'	0°	0"	8" PVC SDR26	8.5"	PSX 12-08 NYLO	12"	12.129"	0"	0"
Invert 2	403.71'	90°	45.5"	8" PVC SDR26	8.5"	PSX 12-08 NYLO	12"	12.129"	13.5"	0"
Invert 3	402.69'	180°	91.125"	8" PVC SDR26	8.5"	PSX 12-08 NYLO	12"	12.129"	1.25"	0"
Invert 4										
Invert 5										
Invert 6										
Invert 7										
Invert 8										

RIGHT-SIDE UP VIEW (int. dimensions)

UPSIDE-DOWN VIEW (int. dimensions)

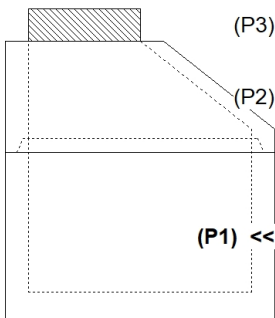
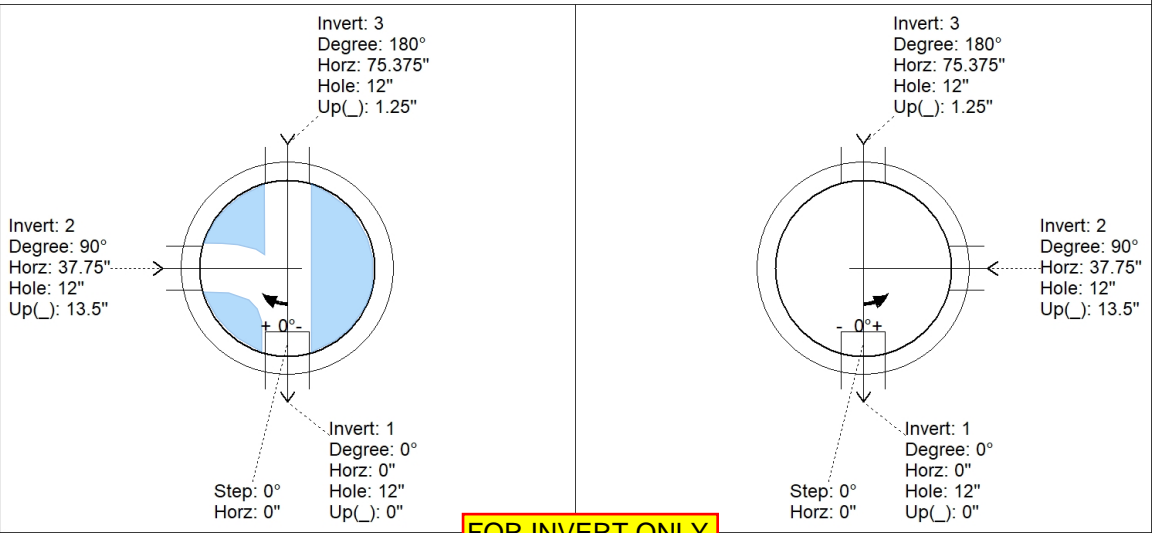

FOR INVERT ONLY

INSIDE WALL DIMENSIONS

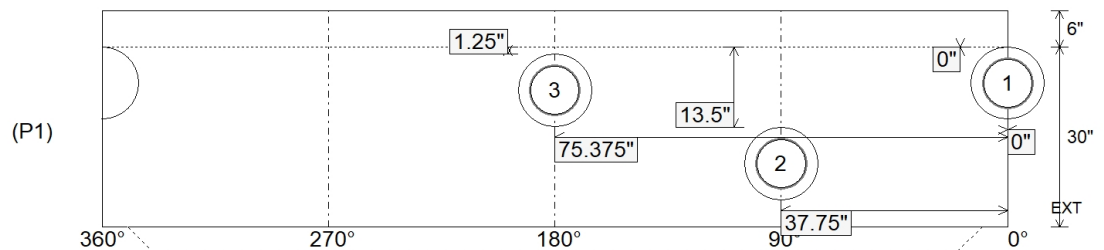

Coating (Int): Coating (Ext):	Seam Up: Tongue Seam Dn: n/a	Wall Thickness: 5" Floor Height: 6"	Height (Int): 30" Height (Ext): 36"	Weight (Net): 3282 lb Volume (Net): 0.84cu.yd
----------------------------------	---------------------------------	----------------------------------------	----------------------------------------	--------------------------------------------------