

Job Name: 25-3333 Canon Court
 Job Location: Dawson Springs, KY
 Contractor: J & J Excavating

Plant: 100

11/19/2025 6:26:01 PM

Tech: J. Horsley -F

PC: A. Chambers



Structure ID: SSMH 1-2

P1 MH048BA30

MH BASE T/n

- P4) 24" - CASTING HEIGHT - 7"
- P3) 24" - GRADE RING F/F - 3"
- P2) 48" - ECC CONE w/ 24" HOLE F/G - 42"
- P1) 48" - MH BASE T/n - 30"
- 1) 48" - MH INVERT CHANNEL - FULL HEIGHT
- 1) JOINT WRAP - 0.065"x6"x50' CONSEAL CS212
- 1) JOINT WRAP PRIMER - CONSEAL CS-75 (1 gal.)
- 1) CASTING - HOE MC-375 F/C Sanitary
- 1) 48" - Conseal CS-102 1.00" (Double)
- 2) PSX - 12-08 NYLO
- 6) MH Step ML-10-TDS-NCR - 10"

0 lb
 202 lb
 3200 lb
 3330 lb
 1440 lb
 0 lb
 0 lb
 271 lb
 0 lb
 16 lb
 0 lb

Structure Total: 8460 lb

Structure Notes:

1. PER ASTM C478 SPECIFICATIONS.
2. CONCRETE = 4,000 PSI AT 28 DAYS.
3. CASTING BY ICAST (HOE MC-375 "SANITARY" F/C).

REINFORCING PER ASTM A615 (GRADE 60).

- CONE (As .12)
- RISER/WALLS (As .12)
- FLOOR (As .31) #5 BARS AT 12" C.C.E.W.

Rim: 407.68' Rim to Invert: 6.74' Slack: 0.88" Sump: 2" Step Position: 0°

Position	Elev	Angle	Ext. (cw)	Pipe	Pipe OD	Connector	Hole	Horz Size	Up ()	Offset
Invert 1	400.94'	0°	0"	8" PVC SDR26	8.5"	PSX 12-08 NYLO	12"	12.129"	0"	0"
Invert 2	401.04'	180°	91.125"	8" PVC SDR26	8.5"	PSX 12-08 NYLO	12"	12.129"	1.25"	0"
Invert 3										
Invert 4										
Invert 5										
Invert 6										
Invert 7										
Invert 8										

RIGHT-SIDE UP VIEW (int. dimensions)

UPSIDE-DOWN VIEW (int. dimensions)

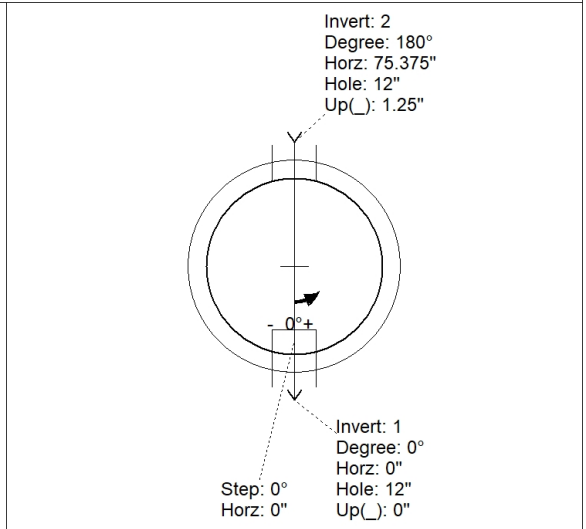
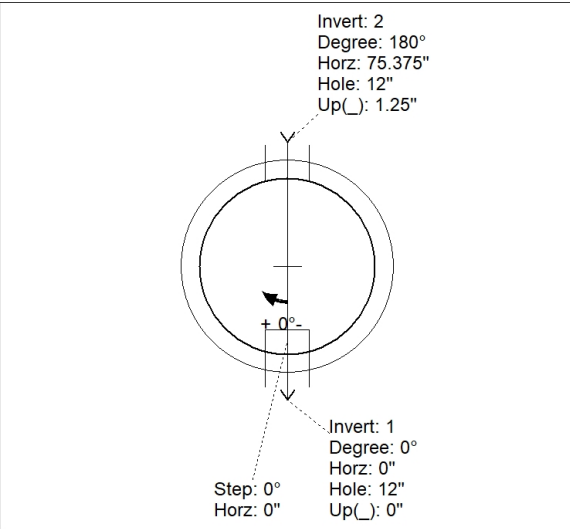
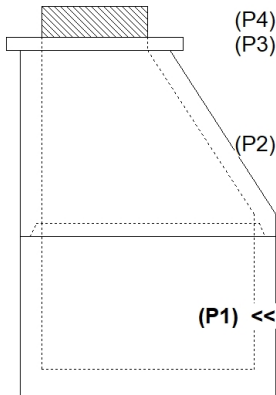

INSIDE WALL DIMENSIONS

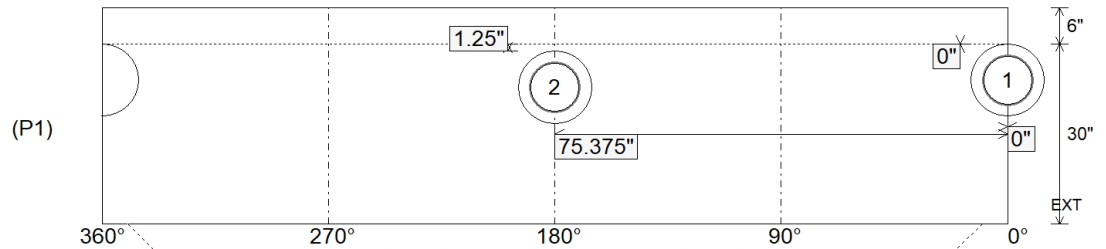

Coating (Int):
 Coating (Ext):

Seam Up: Tongue
 Seam Dn: n/a

Wall Thickness: 5"
 Floor Height: 6"

Height (Int): 30"
 Height (Ext): 36"

Weight (Net): 3330 lb
 Volume (Net): 0.85cu.yd

Job Name: 25-3333 Canon Court
 Job Location: Dawson Springs, KY
 Contractor: J & J Excavating

Plant: 100

11/19/2025 6:26:01 PM

Tech: J. Horsley -F

PC: A. Chambers



Structure ID: SSMH 1-2

P1A MH048BA30

MH BASE T/n

- P4) 24" - CASTING HEIGHT - 7"
- P3) 24" - GRADE RING F/F - 3"
- P2) 48" - ECC CONE w/ 24" HOLE F/G - 42"
- P1) 48" - MH BASE T/n - 30"
- 1) 48" - MH INVERT CHANNEL - FULL HEIGHT
- 1) JOINT WRAP - 0.065"x6"x50' CONSEAL CS212
- 1) JOINT WRAP PRIMER - CONSEAL CS-75 (1 gal.)
- 1) CASTING - HOE MC-375 F/C Sanitary
- 1) 48" - Conseal CS-102 1.00" (Double)
- 2) PSX - 12-08 NYLO
- 6) MH Step ML-10-TDS-NCR - 10"

0 lb
 202 lb
 3200 lb
 3330 lb
 1440 lb
 0 lb
 0 lb
 271 lb
 0 lb
 16 lb
 0 lb

Structure Total: 8460 lb

Structure Notes:

1. PER ASTM C478 SPECIFICATIONS.
2. CONCRETE = 4,000 PSI AT 28 DAYS.
3. CASTING BY ICAST (HOE MC-375 "SANITARY" F/C).

REINFORCING PER ASTM A615 (GRADE 60).

- CONE (As .12)
- RISER/WALLS (As .12)
- FLOOR (As .31) #5 BARS AT 12" C.C.E.W.

Rim: 407.68' Rim to Invert: 6.74' Slack: 0.88" Sump: 2" Step Position: 0°

Position	Elev	Angle	Ext. (cw)	Pipe	Pipe OD	Connector	Hole	Horz Size	Up ()	Offset
Invert 1	400.94'	0°	0"	8" PVC SDR26	8.5"	PSX 12-08 NYLO	12"	12.129"	0"	0"
Invert 2	401.04'	180°	91.125"	8" PVC SDR26	8.5"	PSX 12-08 NYLO	12"	12.129"	1.25"	0"
Invert 3										
Invert 4										
Invert 5										
Invert 6										
Invert 7										
Invert 8										

RIGHT-SIDE UP VIEW (int. dimensions)

UPSIDE-DOWN VIEW (int. dimensions)

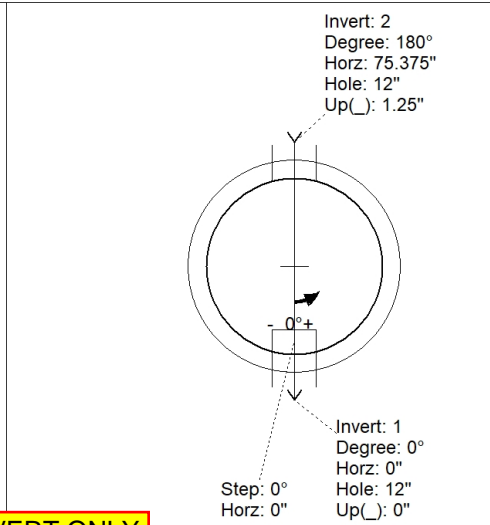
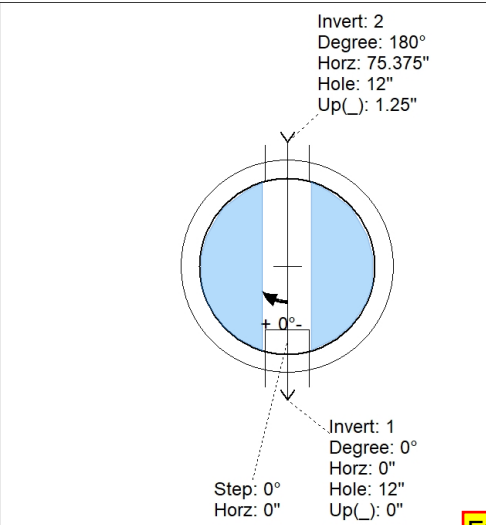
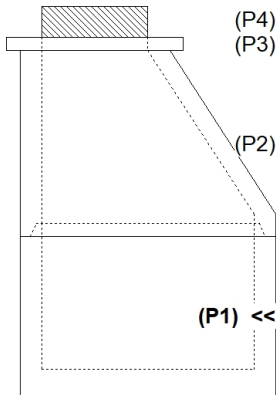

FOR INVERT ONLY

INSIDE WALL DIMENSIONS

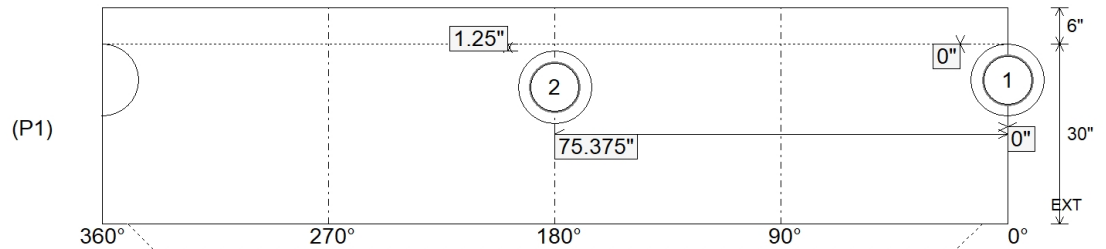

Coating (Int):
 Coating (Ext):

Seam Up: Tongue
 Seam Dn: n/a

Wall Thickness: 5"
 Floor Height: 6"

Height (Int): 30"
 Height (Ext): 36"

Weight (Net): 3330 lb
 Volume (Net): 0.85cu.yd