

Job Name: 25-3310 - Mammoth Cave NP-MACA 12  
 Job Location: Mammoth Cave, KY  
 Contractor: Phillips Brothers

Plant: 100  
 4/2/2026 7:49:59 PM

Tech: J. Horsley - F  
 PC: C. Goff



**Structure ID: CB4**

**P1 BX3636-08BAVF**

**BOX BASE 8inW, 8inF, Variable Ht F/n**

- P3) 24" x 36" - CASTING HEIGHT - 6"
- P2) 36" x 36" - CB FLAT TOP 8"W w/24"x36" HOLE F/F - 6"
- P1) 36" x 36" - BOX BASE 8inW, 8inF, Variable Ht F/n - 34"
- 1) 36" x 36" - Conseal CS-102 1.00"
- 1) 24" x 36" - Conseal CS-102 1.00"
- 2) Hole - 22

0 lb  
 926 lb  
 5216 lb  
 0 lb  
 0 lb  
 0 lb  
 -----  
 Structure Total: 6143 lb

- Structure Notes:**
1. PER ASTM C913 SPECIFICATIONS.
  2. CONCRETE = 4,000 PSI AT 28 DAYS.
  3. NO INVERT CHANNEL.
  4. CASTING SUPPLIED BY OTHERS (HOE-525).

REINFORCING PER ASTM A615 (GRADE 60).  
 - TOP SLAB (As .12) #5 BARS AT 6" C.C.E.W..  
 - WALLS (As .12) #5 BARS AT 6" C.C.E.W..  
 - FLOOR (As .12) #5 BARS AT 6" C.C.E.W.

Rim: 738.58' Rim to Invert: 2.96' Slack: 0.56" Sump: 11.04" Step Position:

Position	Elev	Angle	Ext. (cw)	Pipe	Pipe OD	Connector	Hole	Horz Size	Up ( )	Offset
Invert 1	735.62'	45°	33.625"	15" RCP B WALL	19.5"	Hole 22	22"	31.113"	8.75"	-13"
Invert 2	735.62'	180°	26"	15" RCP B WALL	19.5"	Hole 22	22"	22"	8.75"	0"
Invert 3										
Invert 4										
Invert 5										
Invert 6										
Invert 7										
Invert 8										

RIGHT-SIDE UP VIEW (int. dimensions)

UPSIDE-DOWN VIEW (int. dimensions)

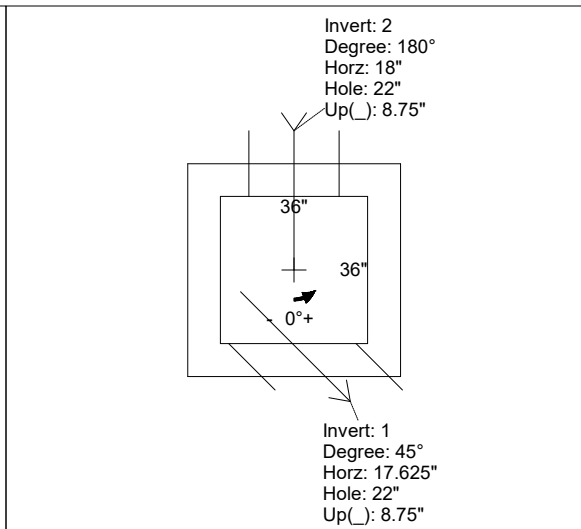
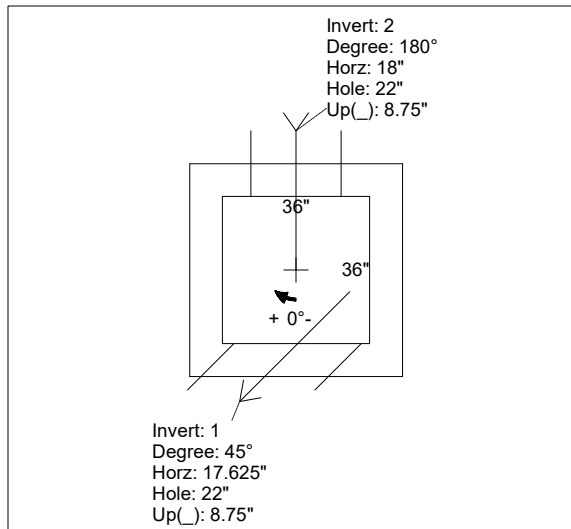
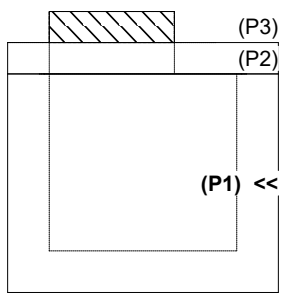

INSIDE WALL DIMENSIONS

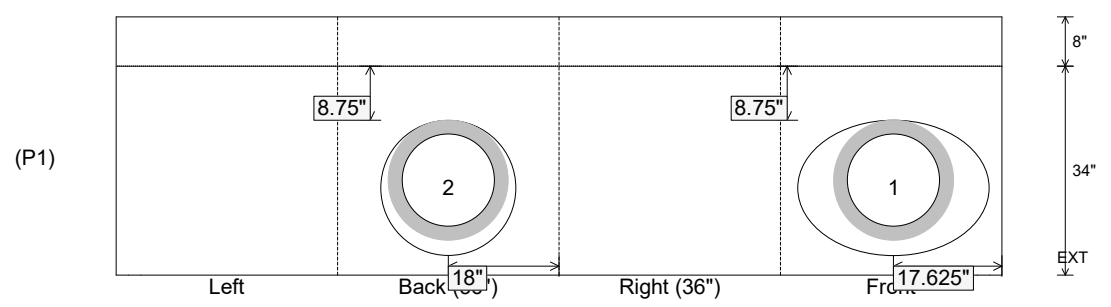

Coating (Int): Coating (Ext):	Seam Up: Flat Seam Dn: n/a	Wall Thickness: 8" Floor Height: 8"	Height (Int): 34" Height (Ext): 42"	Weight (Net): 5216 lb Volume (Net): 1.33cu.yd
----------------------------------	-------------------------------	--	--	--