

Job Name: 25-3310 - Mammoth Cave NP-MACA 12  
 Job Location: Mammoth Cave , KY  
 Contractor: Phillips Brothers

Plant: 100

Tech: J. Horsley - F

4/2/2026 7:50:04 PM

PC: C. Goff



**Structure ID: CB17B**

**P1 BX2436-08BVF**

**BOX BASE 8inW, 8inF, Variable Ht T/n**

- P3) 24" x 36" - CASTING HEIGHT - 6"
- P2) 24" x 36" - BOX RISER 8inW F/G - 18"
- P1) 24" x 36" - BOX BASE 8inW, 8inF, Variable Ht T/n - 35"
- 2) 24" x 36" - Conseal CS-102 1.00"
- 2) Hole - 22

0 lb  
 1837 lb  
 4457 lb  
 0 lb  
 0 lb  
 -----  
 Structure Total: 6294 lb

- Structure Notes:
1. PER ASTM C913 SPECIFICATIONS.
  2. CONCRETE = 4,000 PSI AT 28 DAYS.
  3. NO INVERT CHANNEL.
  4. CASTING SUPPLIED BY OTHERS (HOE-525).

REINFORCING PER ASTM A615 (GRADE 60).  
 - WALLS (As .12) #5 BARS AT 12" C.C.E.W.  
 - FLOOR (As .12) #5 BARS AT 12" C.C.E.W.

Rim: 741.77'    Rim to Invert: 4.96'    Slack: 0.52"    Sump: 0"    Step Position:

Position	Elev	Angle	Ext. (cw)	Pipe	Pipe OD	Connector	Hole	Horz Size	Up ( )	Offset
Invert 1	736.81'	90°	26"	15" RCP B WALL	19.5"	Hole 22	22"	22"	-2.25"	0"
Invert 2	736.81'	180°	20"	15" RCP B WALL	19.5"	Hole 22	22"	22"	-2.25"	0"
Invert 3										
Invert 4										
Invert 5										
Invert 6										
Invert 7										
Invert 8										

RIGHT-SIDE UP VIEW (int. dimensions)

UPSIDE-DOWN VIEW (int. dimensions)

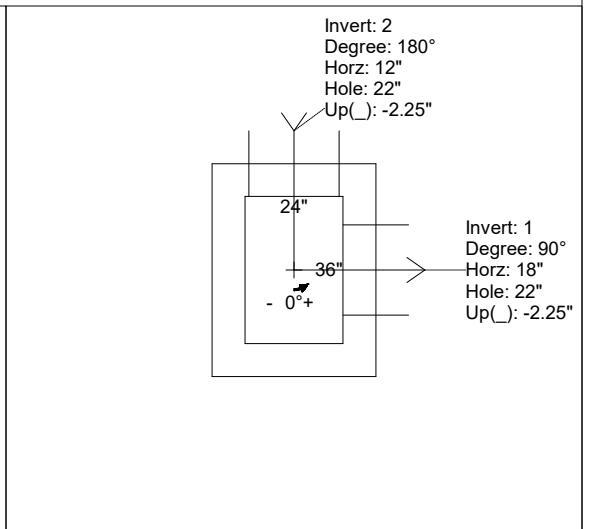
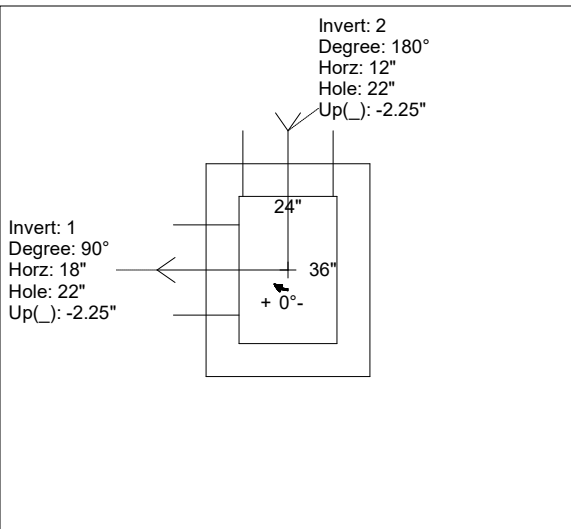
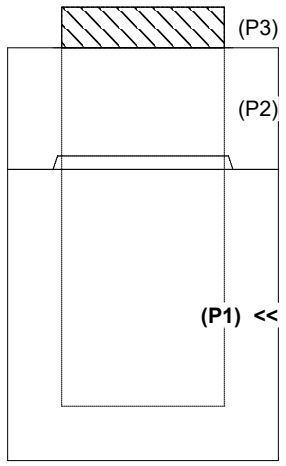

INSIDE WALL DIMENSIONS

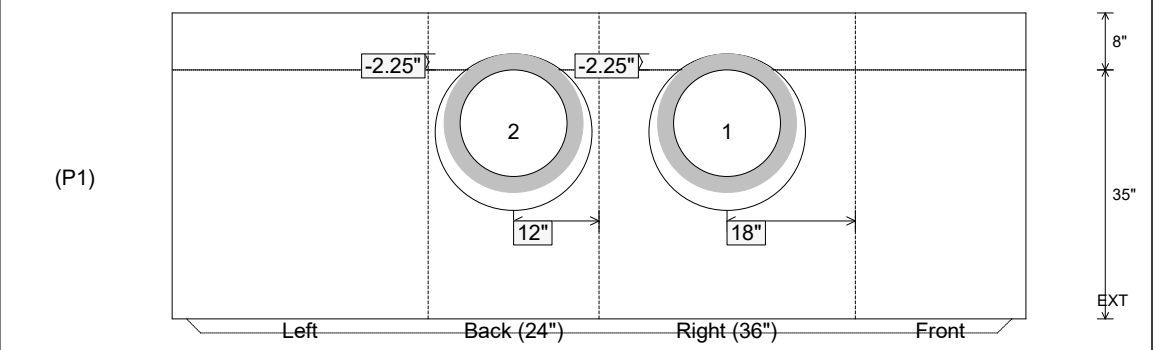

Coating (Int): Coating (Ext):	Seam Up: Tongue Seam Dn: n/a	Wall Thickness: 8" Floor Height: 8"	Height (Int): 35" Height (Ext): 43"	Weight (Net): 4457 lb Volume (Net): 1.14cu.yd
----------------------------------	---------------------------------	----------------------------------------	----------------------------------------	--------------------------------------------------