

Job Name: 25-3310 - Mammoth Cave NP-MACA 12
 Job Location: Mammoth Cave , KY
 Contractor: Phillips Brothers

Plant: 100

4/2/2026 7:49:51 PM

Tech: J. Horsley - F

PC: C. Goff



Structure ID: CB15

P1 MH048BAVF

MH BASE Custom Ht F/n

- P3) 24" x 36" - CASTING HEIGHT - 6"
- P2) 48" - MH FLAT TOP w/24"x36" Hole F/F - 7"
- P1) 48" - MH BASE Custom Ht F/n - 33"
- 1) 48" - Conseal CS-102 1.00"
- 1) 24" x 36" - Conseal CS-102 1.00"
- 1) Hole - 22"
- 3) MH Step ML-10-TDS-NCR - 10"

0 lb
 1044 lb
 3469 lb
 0 lb
 0 lb
 0 lb
 0 lb

 Structure Total: 4513 lb

- Structure Notes:**
1. PER ASTM C478 SPECIFICATIONS.
 2. CONCRETE = 4,000 PSI AT 28 DAYS.
 3. NO INVERT CHANNEL.
 4. CASTING SUPPLIED BY OTHERS (HOE-525).

REINFORCING PER ASTM A615 (GRADE 60).
 - TOP SLAB (As .62) #5 BARS AT 6" C.C.E.W..
 - RISER/WALLS (As .12)
 - FLOOR (As .31) #5 BARS AT 12" C.C.E.W.

Rim: 739.98' Rim to Invert: 3.88' Slack: 0.56" Sump: 0" Step Position: 180°

| Position | Elev | Angle | Ext. (cw) | Pipe | Pipe OD | Connector | Hole | Horz Size | Up () | Offset |
|----------|--------|-------|-----------|----------------|---------|-----------|------|-----------------|--------|--------|
| Invert 1 | 736.1' | 0° | 0" | 15" RCP B WALL | 19.5" | Hole 22 | 22" | 22.854", 0.598" | -2.25" | 0" |
| Invert 2 | | | | | | | | | | |
| Invert 3 | | | | | | | | | | |
| Invert 4 | | | | | | | | | | |
| Invert 5 | | | | | | | | | | |
| Invert 6 | | | | | | | | | | |
| Invert 7 | | | | | | | | | | |
| Invert 8 | | | | | | | | | | |

RIGHT-SIDE UP VIEW (int. dimensions)

UPSIDE-DOWN VIEW (int. dimensions)

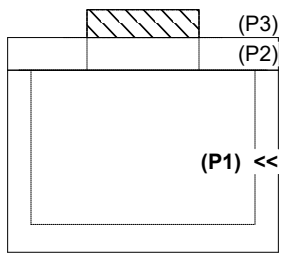
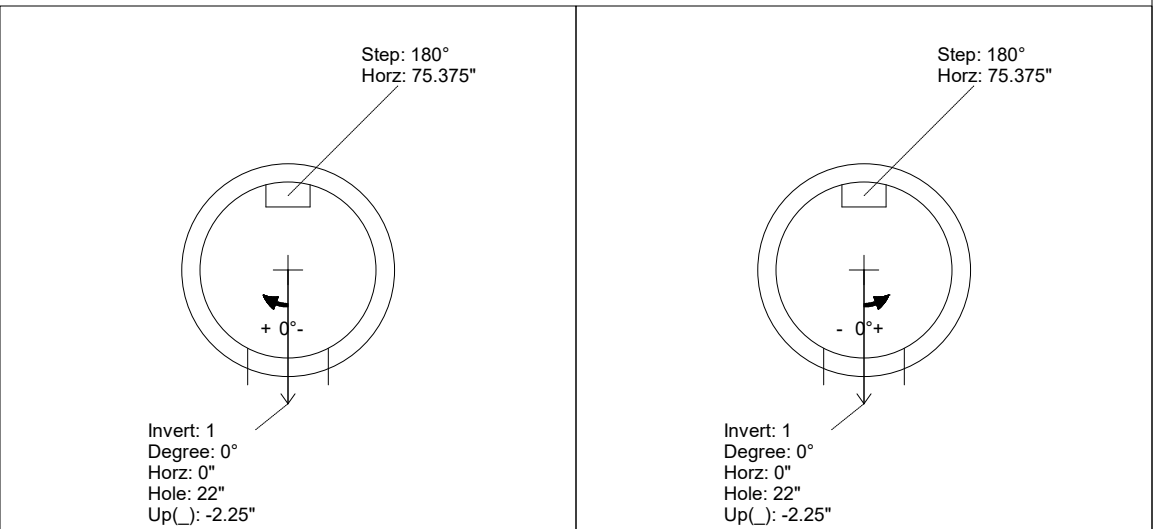

INSIDE WALL DIMENSIONS

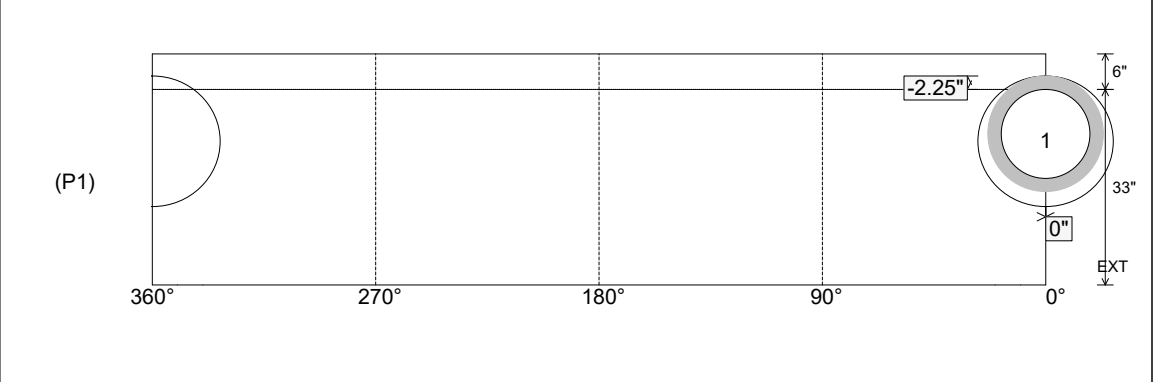

| | | | | |
|----------------------------------|-------------------------------|--|--|--|
| Coating (Int): Coating (Ext): | Seam Up: Flat Seam Dn: n/a | Wall Thickness: 5" Floor Height: 6" | Height (Int): 33" Height (Ext): 39" | Weight (Net): 3469 lb Volume (Net): 0.89cu.yd |
|----------------------------------|-------------------------------|--|--|--|