

Structure ID: MH-AA2

P1 MH060BA48

MH BASE T/n

P5) 24" - CASTING HEIGHT - 7" P4) 60" - MH FLAT TOP w/ 24" ECC Hole F/G - 13" P3) 60" - MH RISER Custom Ht T/G - 34" P2) 60" - MH RISER T/G - 72" P1) 60" - MH BASE T/n - 48" 3) 60" - Conseal CS-102 1.00" 2) Hole - 40" 10) MH Step ML-10-TDS-NCR - 10"	0 lb 2869 lb 3549 lb 6835 lb 7062 lb 0 lb 0 lb 0 lb ----- 20315 lb
--	---

Structure Notes:

1. PER ASTM C478 SPECIFICATIONS.
2. CONCRETE = 4,000 PSI AT 28 DAYS.
3. HOE MC-350 "STORM" BY ICAST
4. REINFORCING PER ASTM A615 (GRADE 60).
 - TOP SLAB (As .62) #5 BARS AT 6" C.C.E.W..
 - RISER/WALLS (As .18)
 - FLOOR (As .37) #5 BARS AT 10" C.C.E.W.

Structure Total: 20315 lb

Rim: 953.5' Rim to Invert: 14.25' Slack: 0.5" Sump: 3.5" Step Position: 270

Position	Elev	Angle	Ext. (cw)	Pipe	Pipe OD	Connector	Hole	Horz Size	Up ()	Offset
Invert 1	939.25'	0°	0"	30" RCP B WALL	37"	Hole 40	40"	43.784"	0"	0"
Invert 2										
Invert 3										
Invert 4										
Invert 5										
Invert 6										
Invert 7										
Invert 8										

RIGHT-SIDE UP VIEW (int. dimensions)

UPSIDE-DOWN VIEW (int. dimenions)

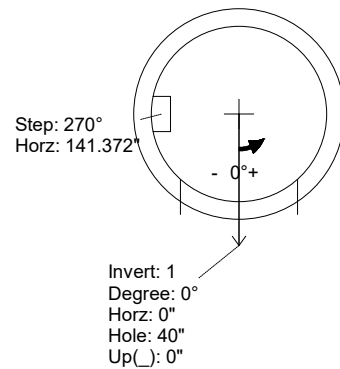
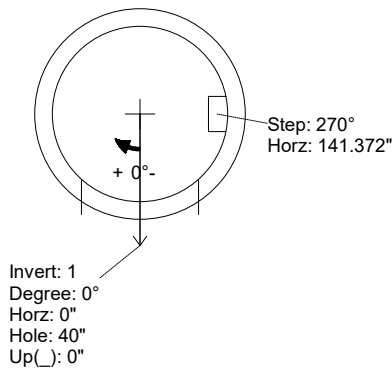
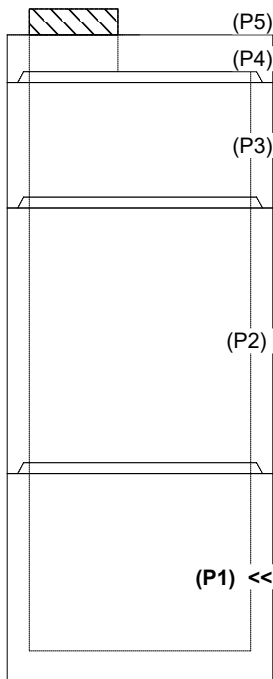

INSIDE WALL DIMENSIONS

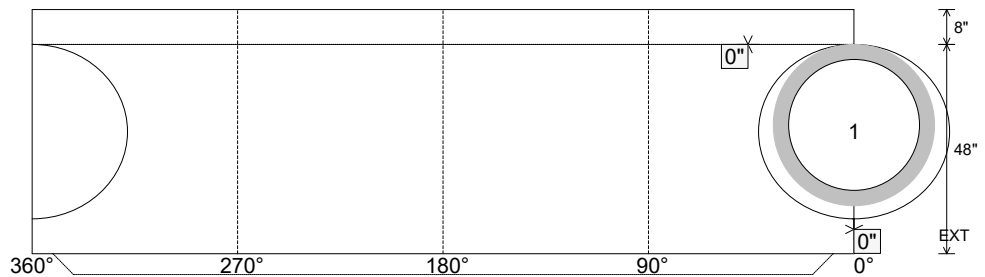

Coating (Int): Coating (Ext):	Seam Up: Tongue Seam Dn: n/a	Wall Thickness: 6" Floor Height: 8"	Height (Int): 48" Height (Ext): 56"	Weight (Net): 7062 lb Volume (Net): 1.8cu.yd
----------------------------------	---------------------------------	--	--	---