

Job Name: 25-3308 Lexmark Setzer
 Job Location: Lexington, Ky
 Contractor: Lagco Inc.

Plant: Beaver Dam

Tech: C.Russ

10/28/2025 9:14:11 AM

PC: C.Goff



Structure ID: AA1A

P3 MH060LD08

MH FLAT TOP w/ 24" ECC Hole

- P4) 24" - CASTING HEIGHT - 7"
- P3) 60" - MH FLAT TOP w/ 24" ECC Hole - 8"
- P2) 60" - MH RISER SPECIAL - 36"
- P1) 60" - MH BASE Custom Ht - 57"
- 1) CASTING - HOE MC-350 F/C Storm
- 2) 60" - SGL 1"x14.5' Butyl (2x)
- 2) Hole - 40
- 7) MH Step ML-10-TDS-NCR - 10"

0 lb
 2429 lb
 3418 lb
 7660 lb
 305 lb
 0 lb
 0 lb
 0 lb

 Structure Total: 13813 lb

Structure Notes:

1. PER ASTM C478 SPECIFICATIONS.
2. CONCRETE = 4,000 PSI AT 28 DAYS.
3. HOE MC-350 "STORM" BY ICAST
4. REINFORCING PER ASTM A615 (GRADE 60).
 - TOP SLAB (As .37) #5 BARS AT 10" C.C.E.W.
 - RISER/WALLS (As .18)
 - FLOOR (As .37) #5 BARS AT 10" C.C.E.W.

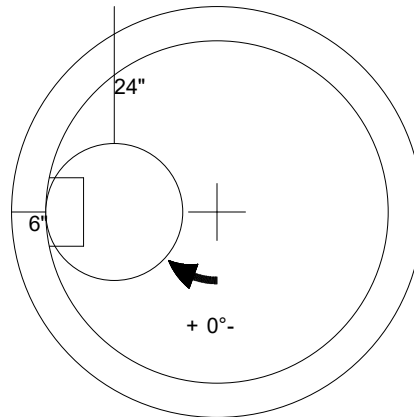

		60" - MH FLAT TOP w/ 24" ECC Hole - 8" - (P3)
--	--	---

Coating (Int):
 Coating (Ext):

Seam Up: Flat
 Seam Dn: Flat

Wall Thickness: 6"

Height (Ext): 8"

Weight (Net): 2429 lb
 Volume (Net): 0.62cu.yd