

Job Name: 25-3304 - Vuteq Warehouse Expansion  
 Job Location: Georgetown, KY  
 Contractor: Brown General Contractors

Plant: 100

3/19/2026 11:42:07 AM

Tech: Jared - A

PC: Erica Bradley



**Structure ID: ST-6**

**P2 MH060RS72S**

**MH RISER SPECIAL T/G**

- P6) 24" - CASTING HEIGHT - 7"
- P5) 48" - ECC CONE w/ 24" HOLE F/G - 36"
- P4) 48" - MH RISER T/G - 60"
- P3) 60" - MH Transition Slab 48" Hole T/G - 15"
- P2) 60" - MH RISER SPECIAL T/G - 72"
- P1) 60" - MH BASE T/n - 60"
- 1) CASTING - HOE MC-315 F/C Storm
- 2) 60" - Conseal CS-102 1.00"
- 2) 48" - Conseal CS-102 1.00"
- 2) Hole - 40"
- 19) MH Step ML-10-TDS-NCR - 10"

0 lb  
 3000 lb  
 4192 lb  
 2204 lb  
 6835 lb  
 8315 lb  
 258 lb  
 0 lb  
 0 lb  
 0 lb  
 0 lb  
 -----  
 24803 lb

Structure Notes:

1. PER ASTM C-478 SPECIFICATIONS
2. CONCRETE: 4,000 PSI AT 28 DAYS
3. REINFORCEMENT: PER ASTM A615
4. STEPS AT 233.5 DEGREES
5. HOE MC-315 FRAME & COVER "STORM" SUPPLIED BY ICAST

Structure Total: 24803 lb

Rim: 919.21' Rim to Invert: 20.73' Slack: 2.26" Sump: 3.5" Step Position: 233.5°

Position	Elev	Angle	Ext. (cw)	Pipe	Pipe OD	Connector	Hole	Horz Size	Up ( )	Offset
Invert 1										
Invert 2	905.66'	107°	67.25"	30" RCP B WALL	37"	Hole 40	40"	43.784"	21.375"	0"
Invert 3										
Invert 4										
Invert 5										
Invert 6										
Invert 7										
Invert 8										

**RIGHT-SIDE UP VIEW (int. dimensions)**

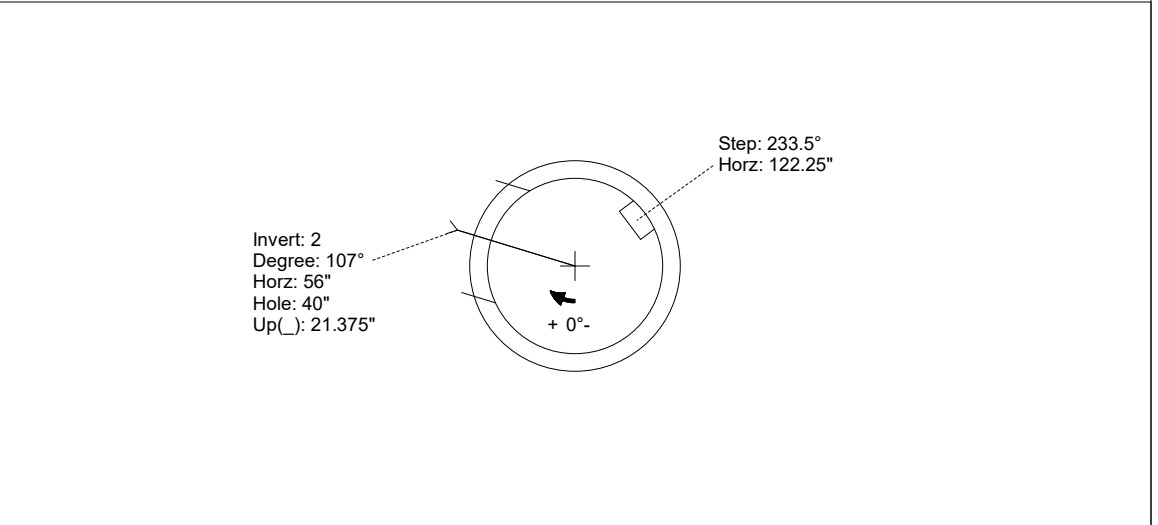
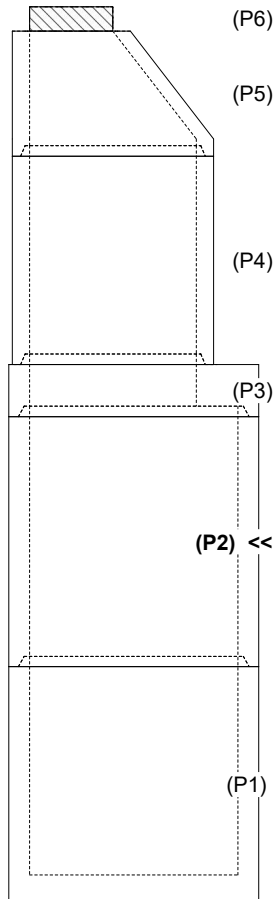

**INSIDE WALL DIMENSIONS**

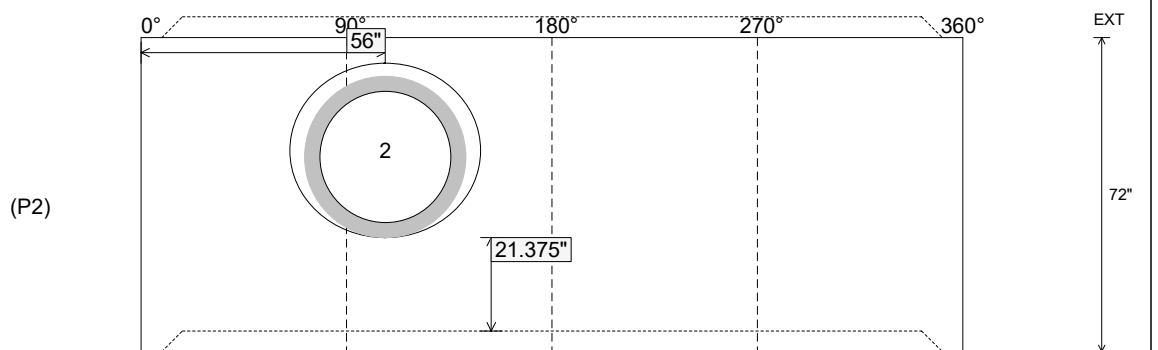

Coating (Int):  
 Coating (Ext):

Seam Up: Tongue  
 Seam Dn: Groove

Wall Thickness: 6"  
 Floor Height: 0"

Height (Int): 72"  
 Height (Ext): 72"

Weight (Net): 6835 lb  
 Volume (Net): 1.75cu.yd