

Job Name: 25-3304 - Vuteq Warehouse Expansion	Plant: 100	Tech: Jared - A	
Job Location: Georgetown, KY Contractor: Brown General Contractors	3/19/2026 11:42:12 AM	PC: Erica Bradley	

Structure ID: ST-13

P2 MH048RS72

MH RISER T/G

P5) 24" - CASTING HEIGHT - 7"	0 lb
P4) 48" - MH FLAT TOP w/ 24" ECC Hole F/F - 7"	1286 lb
P3) 48" - MH RISER SPECIAL F/G - 48"	3037 lb
P2) 48" - MH RISER T/G - 72"	5030 lb
P1) 48" - MH BASE T/n - 60"	5107 lb
1) CASTING - HOE MC-315 F/C Storm	258 lb
3) 48" - Conseal CS-102 1.00"	0 lb
1) Hole - 34	0 lb
1) Hole - 30	0 lb
15) MH Step ML-10-TDS-NCR - 10"	0 lb
Structure Total:	14718 lb

Structure Notes:
 1. PER ASTM C-478 SPECIFICATIONS
 2. CONCRETE: 4,000 PSI AT 28 DAYS
 3. REINFORCEMENT: PER ASTM A615
 4. STEPS AT 124 DEGREES
 5. HOE MC-315 FRAME & COVER "STORM" SUPPLIED BY ICAST

Rim: 917.42' Rim to Invert: 15.94' Slack: 0.28" Sump: 3" Step Position: 124°

Position	Elev	Angle	Ext. (cw)	Pipe	Pipe OD	Connector	Hole	Horz Size	Up (L)	Offset
Invert 1										
Invert 2										
Invert 3										
Invert 4										
Invert 5										
Invert 6										
Invert 7										
Invert 8										

RIGHT-SIDE UP VIEW (int. dimensions)

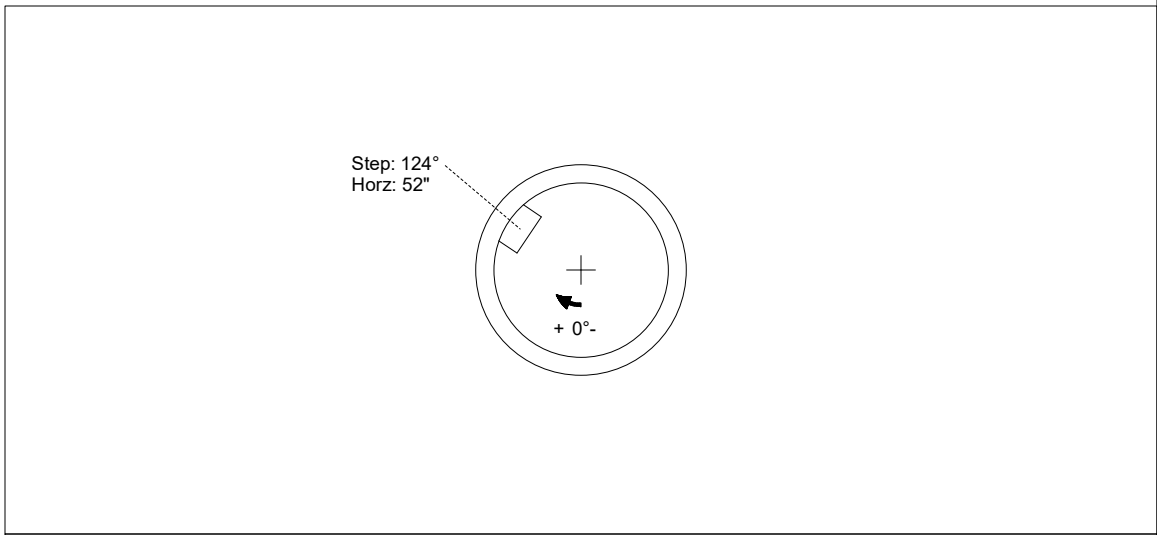
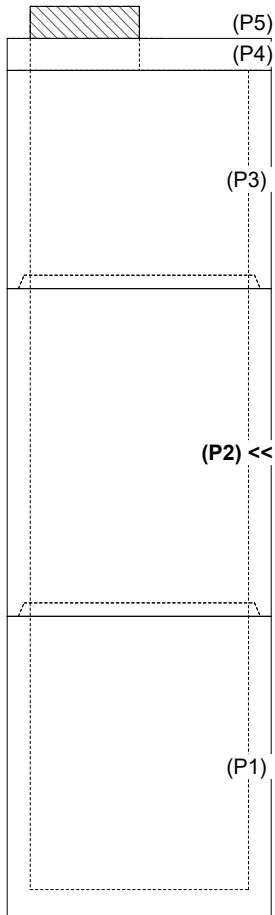

INSIDE WALL DIMENSIONS

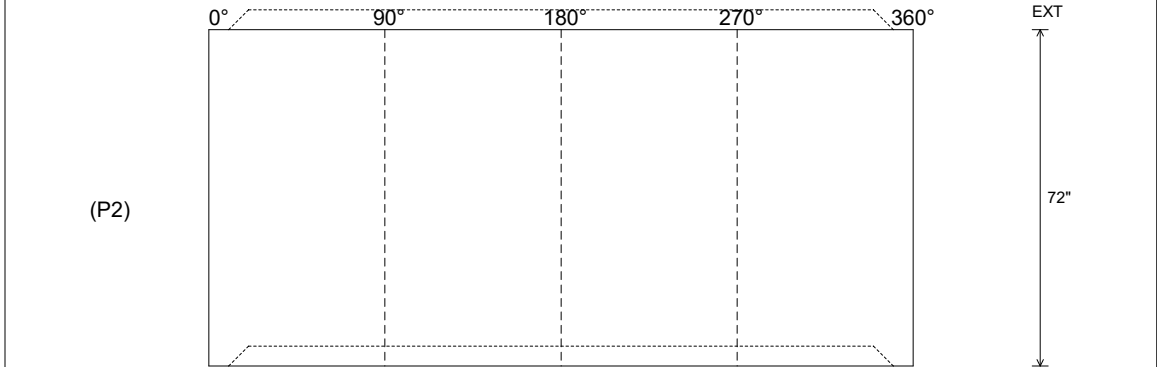

Coating (Int): Coating (Ext):	Seam Up: Tongue Seam Dn: Groove	Wall Thickness: 5" Floor Height: 0"	Height (Int): 72" Height (Ext): 72"	Weight (Net): 5030 lb Volume (Net): 1.28cu.yd
----------------------------------	------------------------------------	--	--	--