

Job Name: 25-3304 - Vuteq Warehouse Expansion  
 Job Location: Georgetown, KY  
 Contractor: Brown General Contractors

Plant: 100

3/19/2026 11:42:11 AM

Tech: Jared - A

PC: Erica Bradley



**Structure ID: ST-10**

**P3 MH048RS48S**

**MH RISER SPECIAL T/G**

- P5) 24" - CASTING HEIGHT - 7"
- P4) 48" - ECC CONE w/ 24" HOLE F/G - 24"
- P3) 48" - MH RISER SPECIAL T/G - 48"
- P2) 48" - MH RISER T/G - 48"
- P1) 48" - MH BASE T/n - 42"
- 1) CASTING - HOE MCB-315-B Fr./Bar Grate
- 3) 48" - Conseal CS-102 1.00"
- 1) Hole - 32
- 1) Hole - 24
- 1) Hole - 26
- 13) MH Step ML-10-TDS-NCR - 10"

0 lb  
 1550 lb  
 3156 lb  
 3353 lb  
 3668 lb  
 255 lb  
 0 lb  
 0 lb  
 0 lb  
 0 lb  
 0 lb  
 \_\_\_\_\_  
 11982 lb

Structure Notes:

1. PER ASTM C-478 SPECIFICATIONS
2. CONCRETE: 4,000 PSI AT 28 DAYS
3. REINFORCEMENT: PER ASTM A615
4. STEPS AT 180 DEGREES
5. HOE MCB-315-B FRAME & BAR GRATE SUPPLIED BY ICAST

Structure Total: 11982 lb

Rim: 921.92' Rim to Invert: 14.02' Slack: 2.24" Sump: 3" Step Position: 180°

| Position | Elev   | Angle | Ext. (cw) | Pipe     | Pipe OD | Connector | Hole | Horz Size | Up ( )  | Offset |
|----------|--------|-------|-----------|----------|---------|-----------|------|-----------|---------|--------|
| Invert 1 |        |       |           |          |         |           |      |           |         |        |
| Invert 2 | 916.5' | 117°  | 59.25"    | 18" HDPE | 21.2"   | Hole 24   | 24"  | 25.133"   | 10.375" | 0"     |
| Invert 3 |        |       |           |          |         |           |      |           |         |        |
| Invert 4 |        |       |           |          |         |           |      |           |         |        |
| Invert 5 |        |       |           |          |         |           |      |           |         |        |
| Invert 6 |        |       |           |          |         |           |      |           |         |        |
| Invert 7 |        |       |           |          |         |           |      |           |         |        |
| Invert 8 |        |       |           |          |         |           |      |           |         |        |

**RIGHT-SIDE UP VIEW (int. dimensions)**

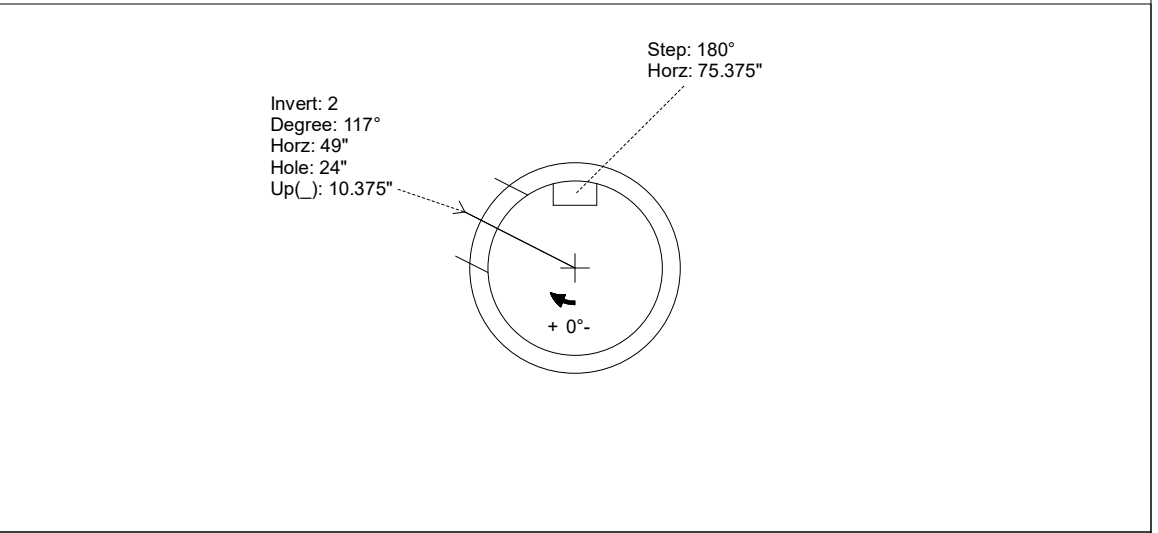
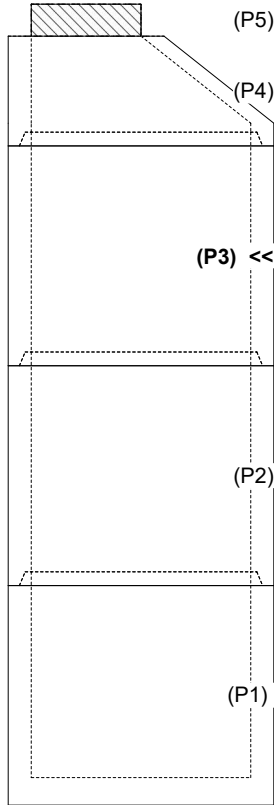

**INSIDE WALL DIMENSIONS**

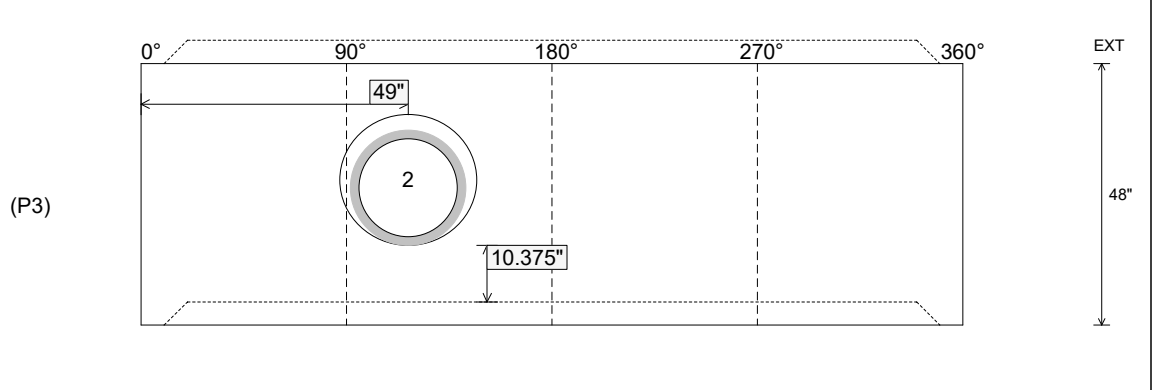

Coating (Int):  
 Coating (Ext):

Seam Up: Tongue  
 Seam Dn: Groove

Wall Thickness: 5"  
 Floor Height: 0"

Height (Int): 48"  
 Height (Ext): 48"

Weight (Net): 3156 lb  
 Volume (Net): 0.81cu.yd