

Structure ID: 110 (4242+59)

P1 MH060BA72

MH BASE T/n

P5) 24" - CASTING HEIGHT - 7" P4) 48" - ECC CONE w/ 24" HOLE F/G - 30" P3) 48" - MH RISER T/G - 24" P2) 60" - MH Transition Slab 48" Hole T/G - 13" P1) 60" - MH BASE T/n - 72" 1) CASTING - EJ 1925 F/C 1) 60" - SGL 1"x14.5' Butyl (2x) 2) 48" - SGL 1"x14.5' Butyl (2x) 2) Hole - 22 2) Hole - 10 11) MH Step ML-10-TDS-NCR - 10"	0 lb 2050 lb 1677 lb 1928 lb 9780 lb 250 lb 0 lb 0 lb 0 lb 0 lb 0 lb 0 lb ----- 15684 lb	Structure Notes: **INDOT STATE PROJECT** 1. INDOT MH TYPE C / ASTM C478 SPEC'S. 2. CONCRETE = 4,000 PSI AT 28 DAYS. 3. NO INVERT CHANNEL. 4. CASTING BY ICAST (INDOTY TY.4/ EJ 1925 F/C) REINFORCING PER ASTM A615 (GRADE 60). - CONE (As .12) - RISER/WALLS (As .12) - FLOOR (As .62) #5 BARS AT 6" C.C.E.W.
--	---	--

Structure Total: 15684 lb

Rim: 387.98' Rim to Invert: 12.29' Slack: 1.48" Sump: 0" Step Position: 335°

Position	Elev	Angle	Ext. (cw)	Pipe	Pipe OD	Connector	Hole	Horz Size	Up ()	Offset
Invert 1	375.69'	40°	25.125"	15" RCP B WALL	19.5"	Hole 22	22"	22.525"	-2.25"	0"
Invert 2	375.69'	196°	123.125"	15" RCP B WALL	19.5"	Hole 22	22"	22.525"	-2.25"	0"
Invert 3	375.69'	90°	56.5"	6" HDPE (perf pipe)	6.9"	Hole 10	10"	10.047"	-0.5"	0"
Invert 4	375.69'	270°	169.625"	6" HDPE (perf pipe)	6.9"	Hole 10	10"	10.047"	-0.5"	0"
Invert 5										
Invert 6										
Invert 7										
Invert 8										

RIGHT-SIDE UP VIEW (int. dimensions)

UPSIDE-DOWN VIEW (int. dimensions)

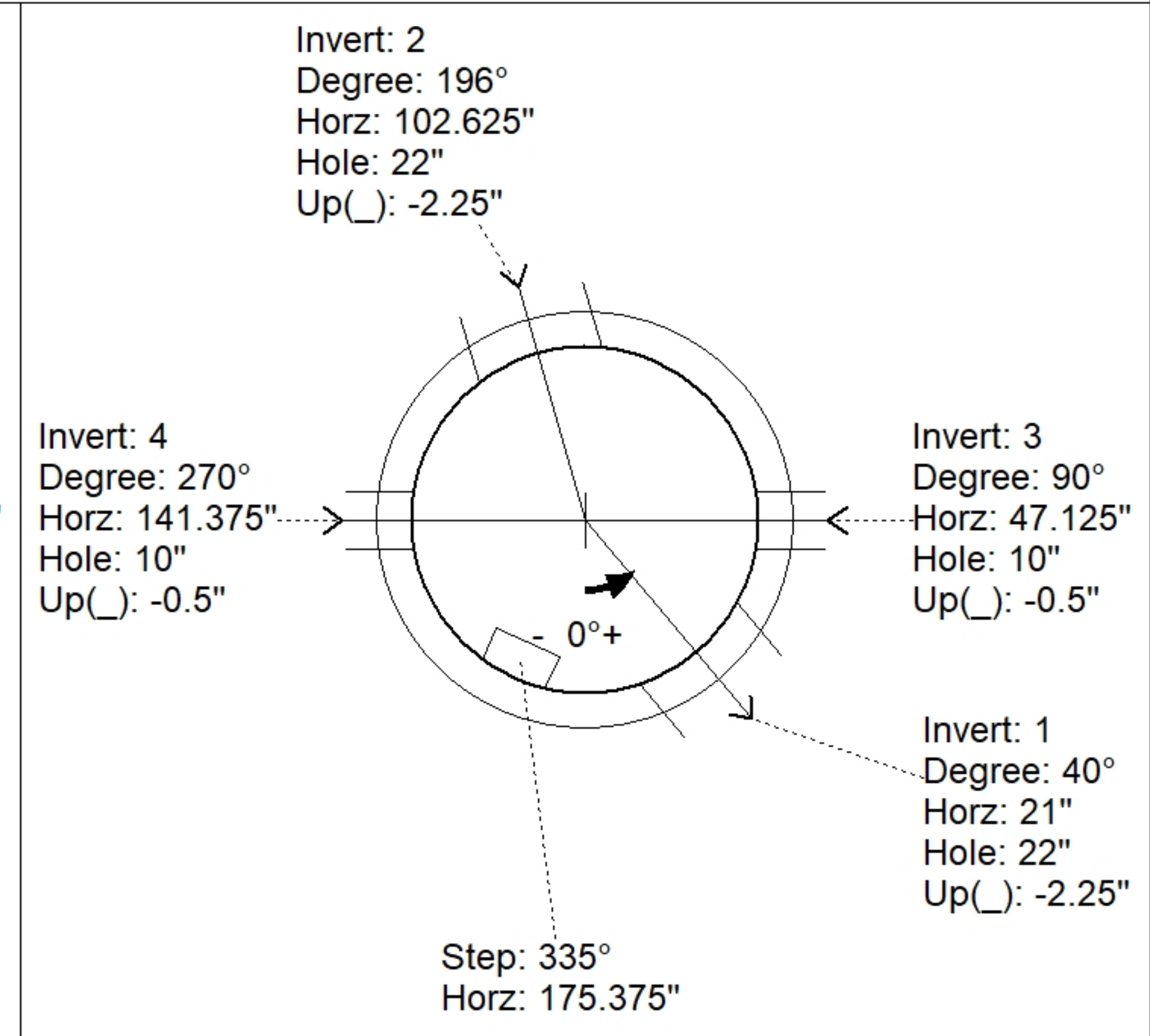
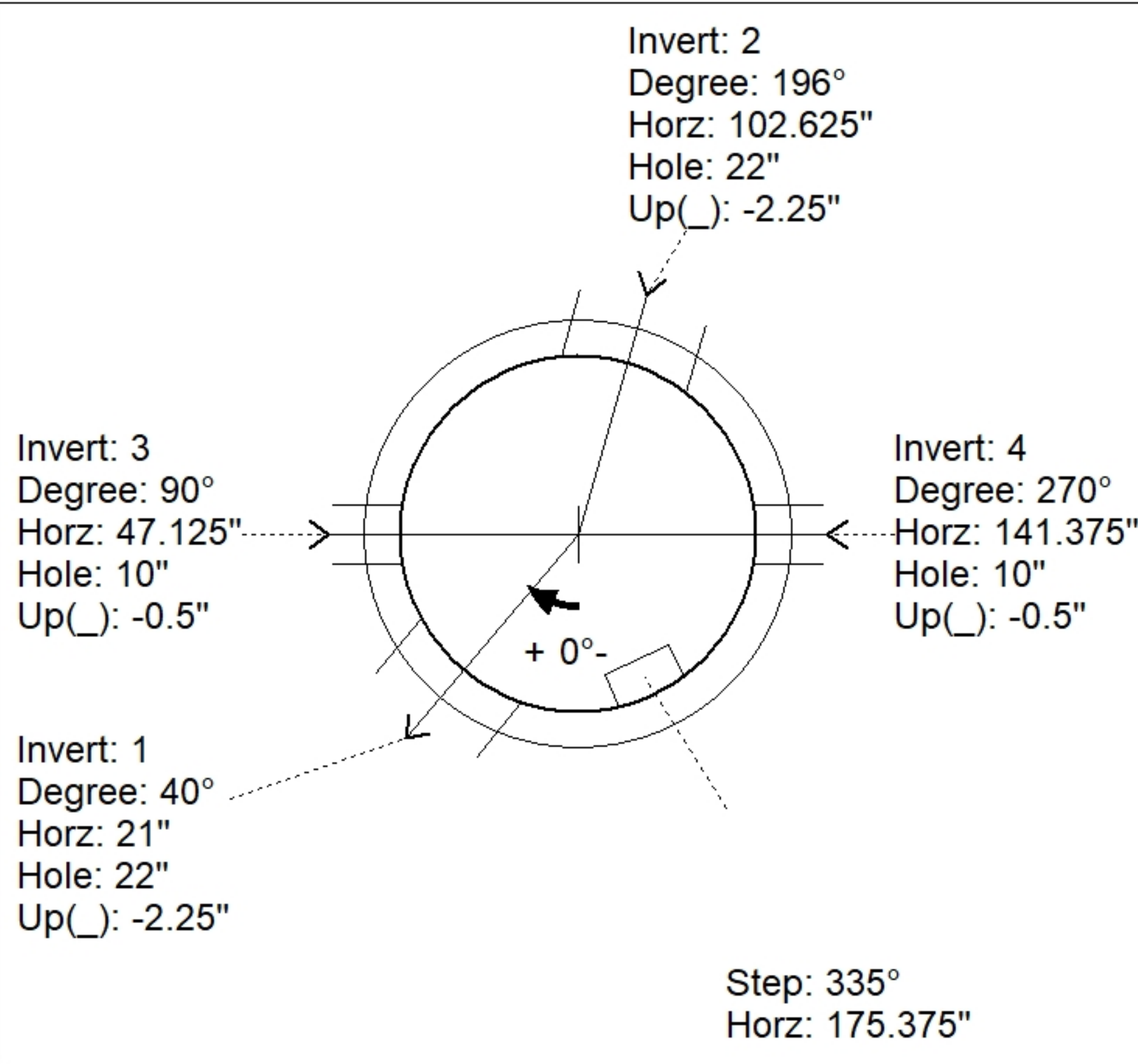
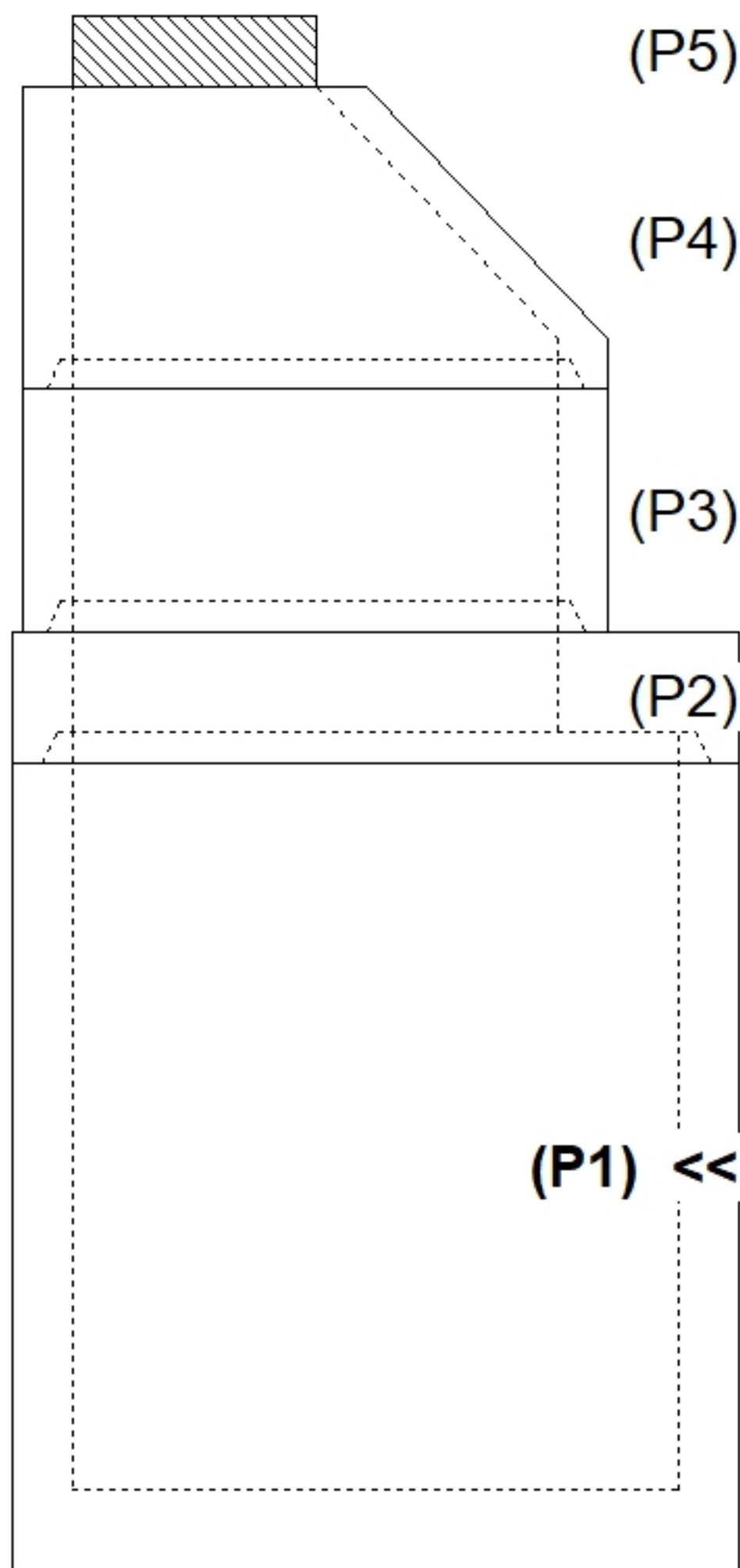

INSIDE WALL DIMENSIONS

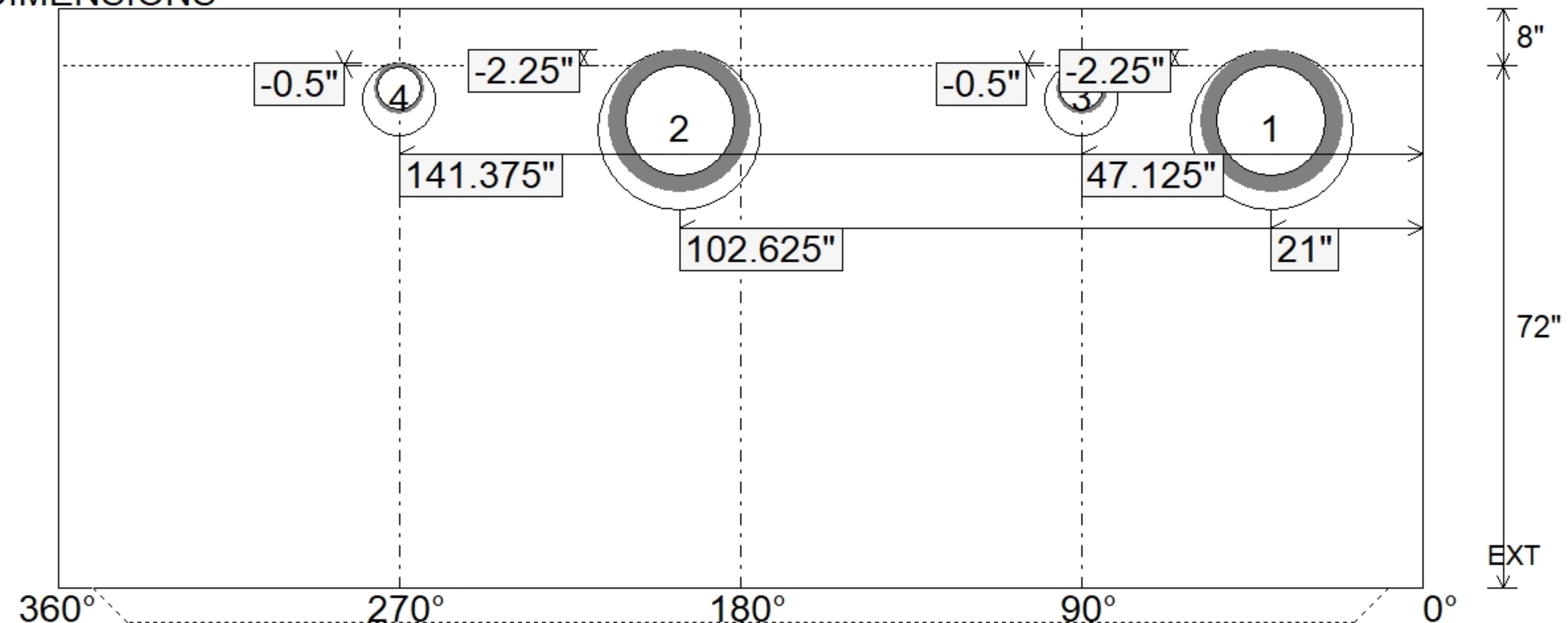

Coating (Int):	Seam Up: Tongue	Wall Thickness: 6"	Height (Int): 72"	Weight (Net): 9780 lb
Coating (Ext):	Seam Dn: n/a	Floor Height: 8"	Height (Ext): 80"	Volume (Net): 2.5cu.yd