

TOP VIEW

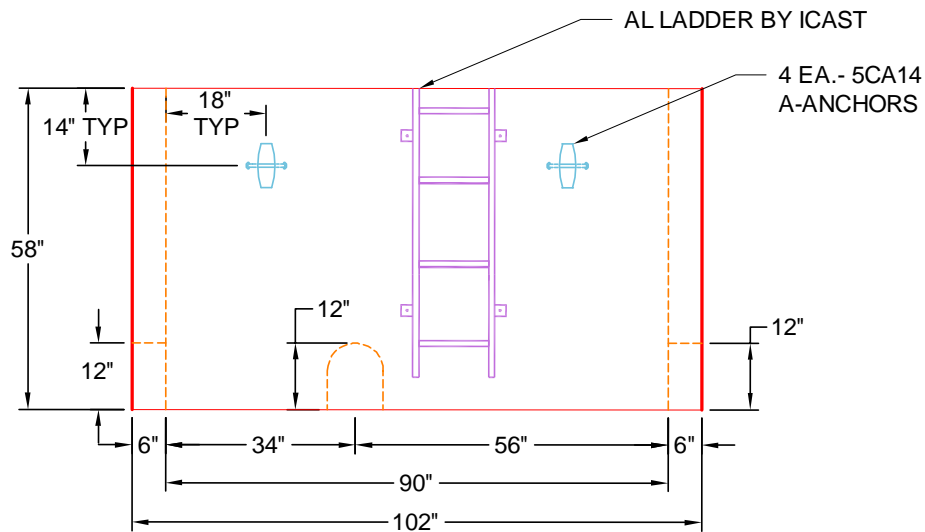

FRONT VIEW

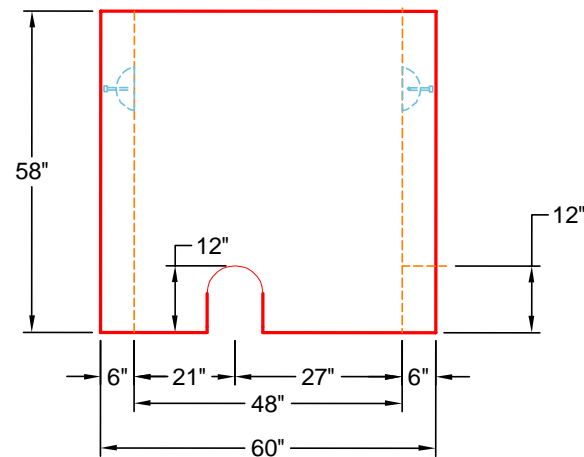

SIDE VIEW

GENERAL NOTES :

1. CONCRETE 28 DAY COMPRESSIVE STRENGTH OF 5000 PSI.
2. REINFORCING PER ASTM A-615.
WALLS #4 BAR @ 8" C.C.E.W.
3. VAULT JOINT TO BE SEALED WITH CONCRETE SEALANTS, INC. CS-102 ROLL BUTYL MASTIC
4. WEIGHT: WALLS = 8,690 LBS

REVISION INFORMATION

REV. DATE: NO REVISIONS TO DATE



PRODUCTION DRAWING: 4'X7.5'x5' DOGHOUSE RISER

CUSTOMER: WARREN COUNTY WATER DISTRICT

PROJECT: SOUTHERN TIRE MART VAULTS

STRUCTURE: ICAST LI3

QUOTE/SALES ORDER NO: 25-3294

CHK BY: B SMITH

DRAWN BY: C. RUSS

DATE: 09/5/25

SCALE: NTS

PG. 1 of 1