

**GENERAL NOTES**

1. CONCRETE 28 DAY COMPRESSIVE STRENGTH OF 5000 PSI.
2. REINFORCING PER ASTM A-615.  
WALLS #4 BAR @ 8" C.C.E.W.
3. VAULT JOINT TO BE SEALED WITH CONCRETE SEALANTS, INC. CS-102 ROLL BUTYL MASTIC
4. WEIGHT: WALLS = 8,020 LBS

AL LADDER BY ICAST

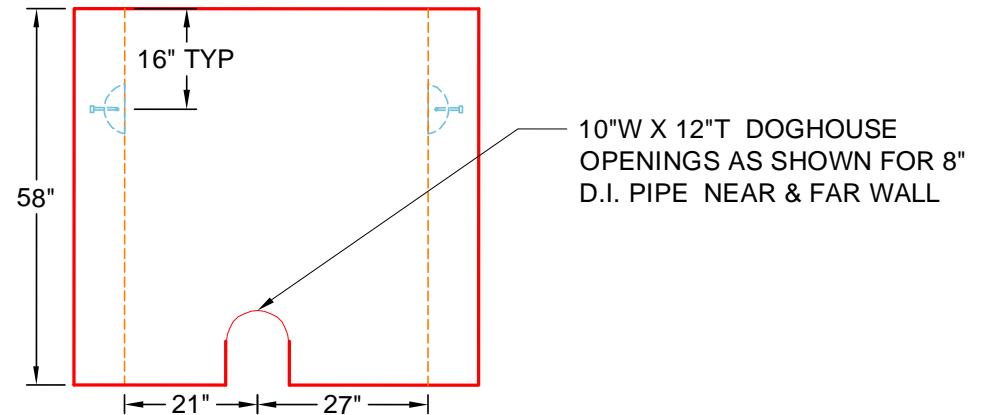
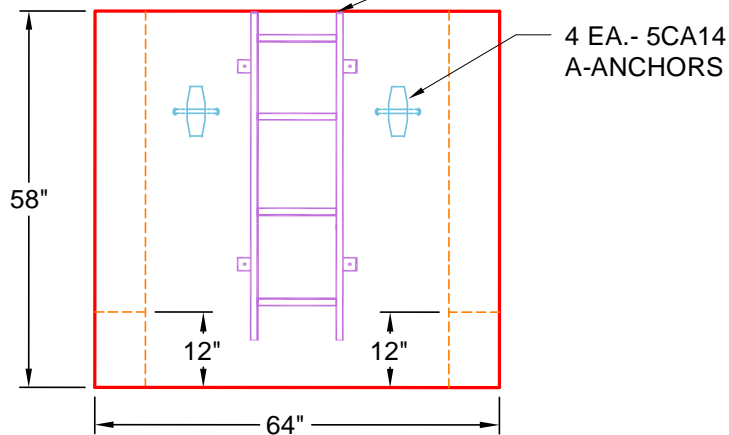

**REVISION INFORMATION**

REV. DATE: NO REVISIONS TO DATE



SUBMITTAL DRAWING: 48"x90"x60" DOGHOUSE RISER

CUSTOMER: WARREN COUNTY WATER DISTRICT

PROJECT: SOUTHERN TIRE MART VAULTS

STRUCTURE: ICAST LI2

QUOTE/SALES ORDER NO: 25-3294

CHK BY: B SMITH DRAWN BY: C. RUSS

DATE: 09/5/25 SCALE: NTS PG. 1 of 1