

Job Name: 25-3292 Arbor View Sec. 2
Job Location: Eminence, KY
Contractor: Core & Main LP (Lou)

PC: J.Jarvis
 TECH: C.Russ
 Plant: Beaver Dam



Structure ID: **SSMH G1**

Spec: Sanitary
 Type: SAN.MH
 Size: 48"

Rim: 916.16'
 Invert: 911.44'
 Rim to Invert: 4.72'

Sump: 2"
 Floor (Top): 911.273'
 Floor Height: 6"

Floor (Bot): 910.773'
 Overall Height: 5.333'
 Slack: 0.64"

Structure Notes:

1. PER ASTM C478 SPECIFICATIONS.
2. CONCRETE = 4,000 PSI AT 28 DAYS.
3. MC-315 "SANITARY" BY ICAST
4. REINFORCING PER ASTM A615 (GRADE 60).
 - CONE (As .12)
 - RISER/WALLS (As .12)
 - FLOOR (As .31) #5 BARS AT 12" C.C.E.W.
5. NO STEPS

STRUCTURE SUMMARY:

P4) 24" - CASTING HEIGHT - 7"	0 lb
P3) 24" - GRADE RING F/F - 3"	202 lb
P2) 48" - MH FLAT TOP w/ 24" ECC Hole F/G - 12"	1561 lb
P1) 48" - MH BASE T/n - 36"	3779 lb
1) 48" - MH INVERT CHANNEL - FULL HEIGHT	1440 lb
1) JOINT WRAP - 0.065"x6"x50' CONSEAL CS212	0 lb
1) JOINT WRAP PRIMER - CONSEAL CS-75 (1 gal.)	0 lb
1) CASTING - HOE MC-315 F/C Sanitary	258 lb
1) 48" - DBL 1"x14.5' Butyl (2x)	0 lb
1) A-Lok - 0285	1 lb
2) A-Lok - 0210	2 lb
Structure Total:	7243 lb

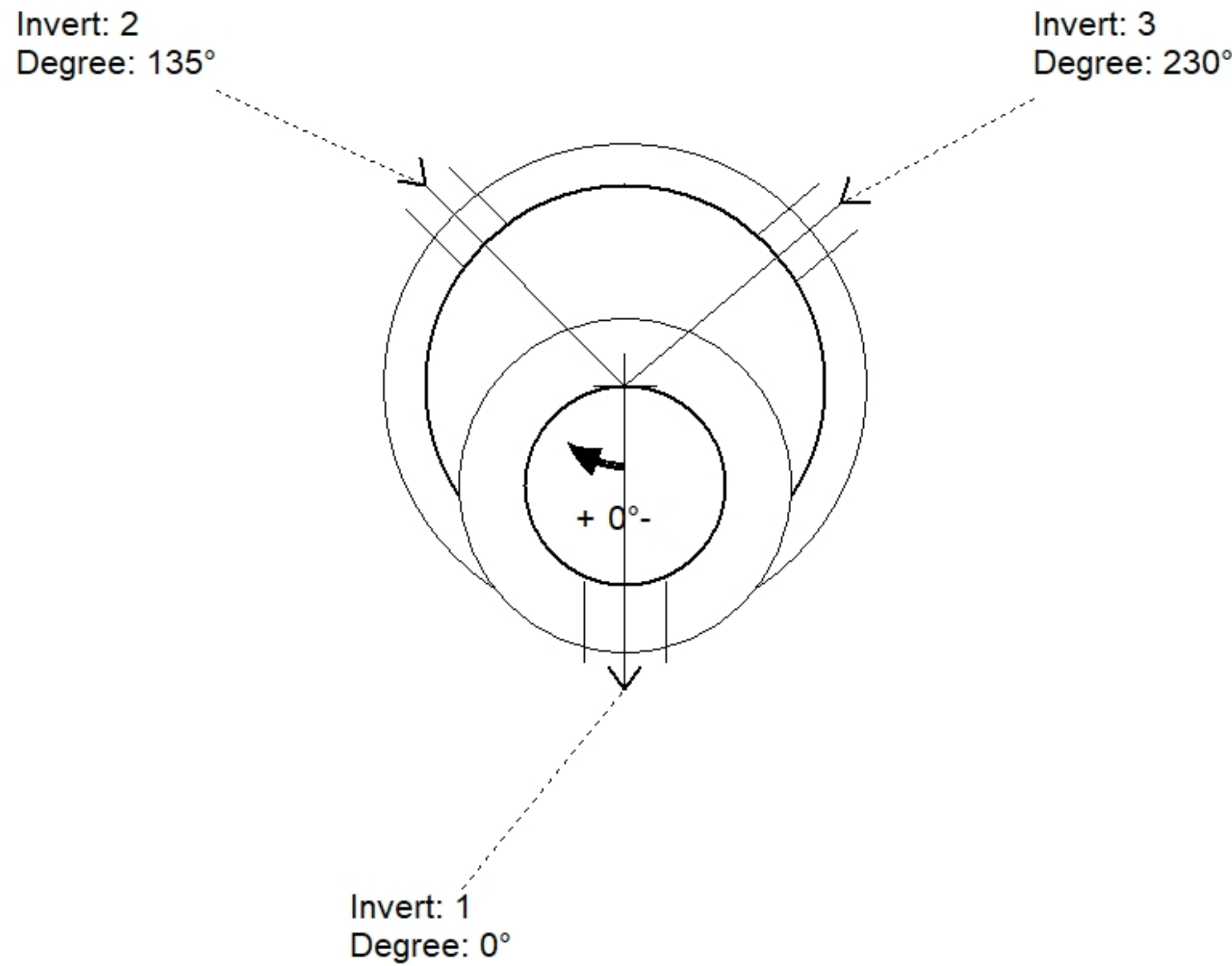

Position	Elev	Angle	Pipe	Pipe OD	Hole	Connector	Up (")	Ref
Rim	916.16'							
Reducer								
Invert 1	911.44'	0°	8" PVC SDR35	8.5"	9.75"	A-Lok 0285	1.125"	P1
Invert 2	911.64'	135°	6" PVC SDR35	6.25"	7.25"	A-Lok 0210	3.775"	P1
Invert 3	911.64'	230°	6" PVC SDR35	6.25"	7.25"	A-Lok 0210	3.775"	P1
Invert 4								
Invert 5								
Invert 6								
Invert 7								
Invert 8								

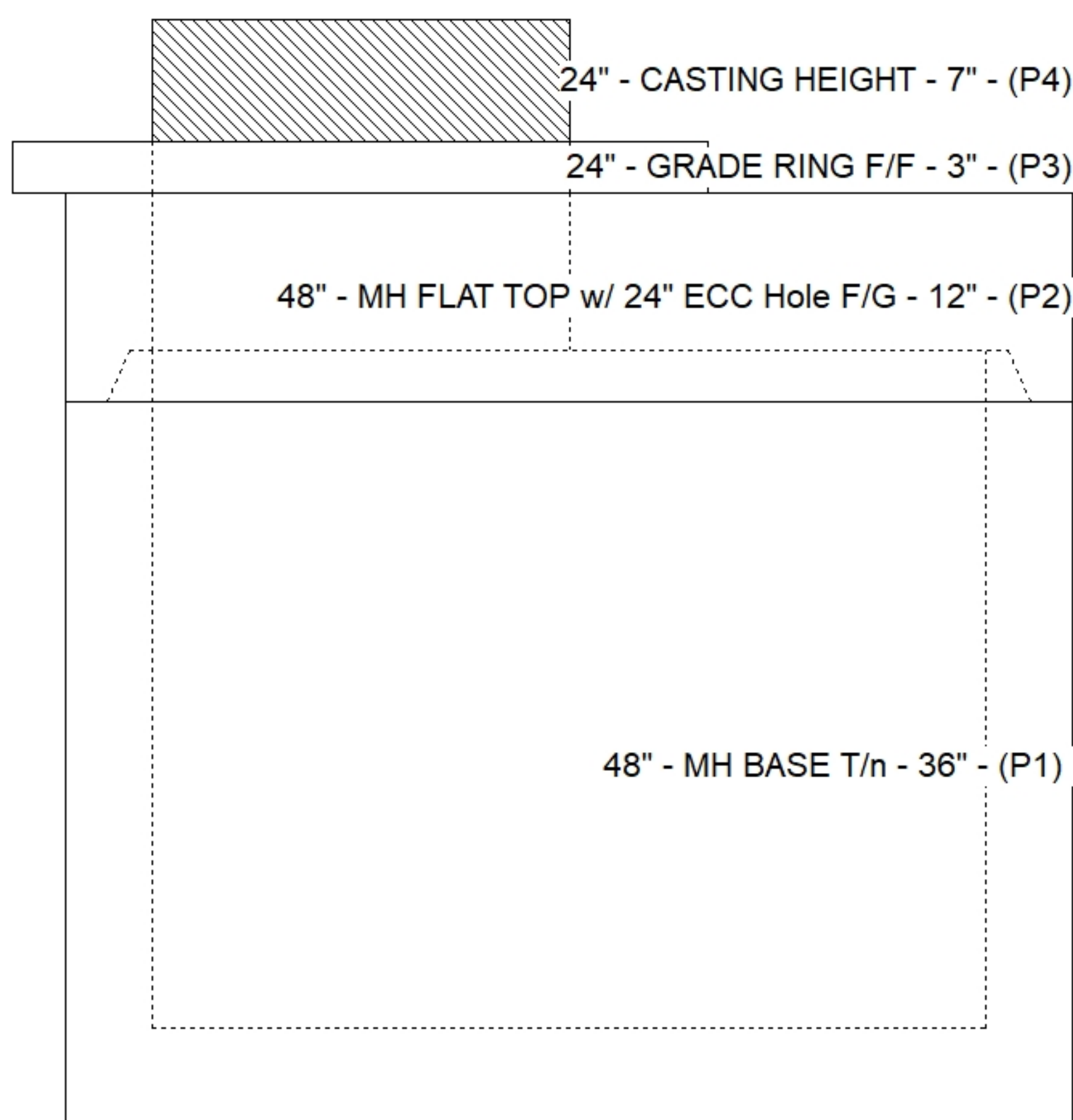

Default - Interior Dimensions

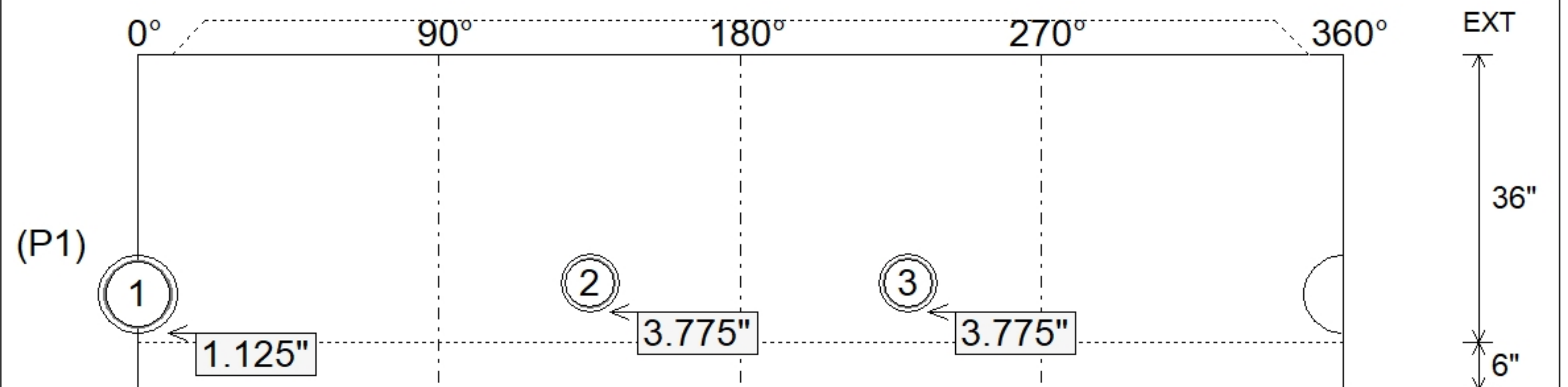

Submittal Drawing
 10/14/2025 8:12:59 AM

SUBMITTAL
 APPROVED BY: