

Structure ID: SSMH G4

P1 MH048BA24

MH BASE T/n

P5) 24" - CASTING HEIGHT - 7" P4) 24" - GRADE RING F/F - 3" P3) 48" - ECC CONE w/ 24" HOLE F/G - 30" P2) 48" - MH RISER T/G - 36" P1) 48" - MH BASE T/n - 24" 1) 48" - MH INVERT CHANNEL - FULL HEIGHT 1) JOINT WRAP - 0.065"x6"x50' CONSEAL CS212 1) JOINT WRAP PRIMER - CONSEAL CS-75 (1 gal.) 1) CASTING - HOE MC-315 F/C Sanitary 2) 48" - DBL 1"x14.5' Butyl (2x) 2) A-Lok - 0285	0 lb 202 lb 2050 lb 2515 lb 2944 lb 1440 lb 0 lb 0 lb 258 lb 0 lb 2 lb <hr style="width: 50px; margin-left: auto; margin-right: 0;"/> Structure Total: 9411 lb
--	---

Structure Notes:

1. PER ASTM C478 SPECIFICATIONS.
2. CONCRETE = 4,000 PSI AT 28 DAYS.
3. MC-315 "SANITARY" BY ICAST
4. REINFORCING PER ASTM A615 (GRADE 60).
 - CONE (As .12)
 - RISER/WALLS (As .12)
 - FLOOR (As .31) #5 BARS AT 12" C.C.E.W.
5. NO STEPS

Rim: 899.06' Rim to Invert: 8.19' Slack: 0.28" Sump: 2" Step Position: 270°

Position	Elev	Angle	Ext. (cw)	Pipe	Pipe OD	Connector	Hole	Horz Size	Up ()	Offset
Invert 1	890.87'	0°	0"	8" PVC SDR35	8.5"	A-Lok 0285	9.75"	9.818"	1.125"	0"
Invert 2	890.97'	148°	74.875"	8" PVC SDR35	8.5"	A-Lok 0285	9.75"	9.818"	2.375"	0"
Invert 3										
Invert 4										
Invert 5										
Invert 6										
Invert 7										
Invert 8										

RIGHT-SIDE UP VIEW (int. dimensions)

UPSIDE-DOWN VIEW (int. dimensions)

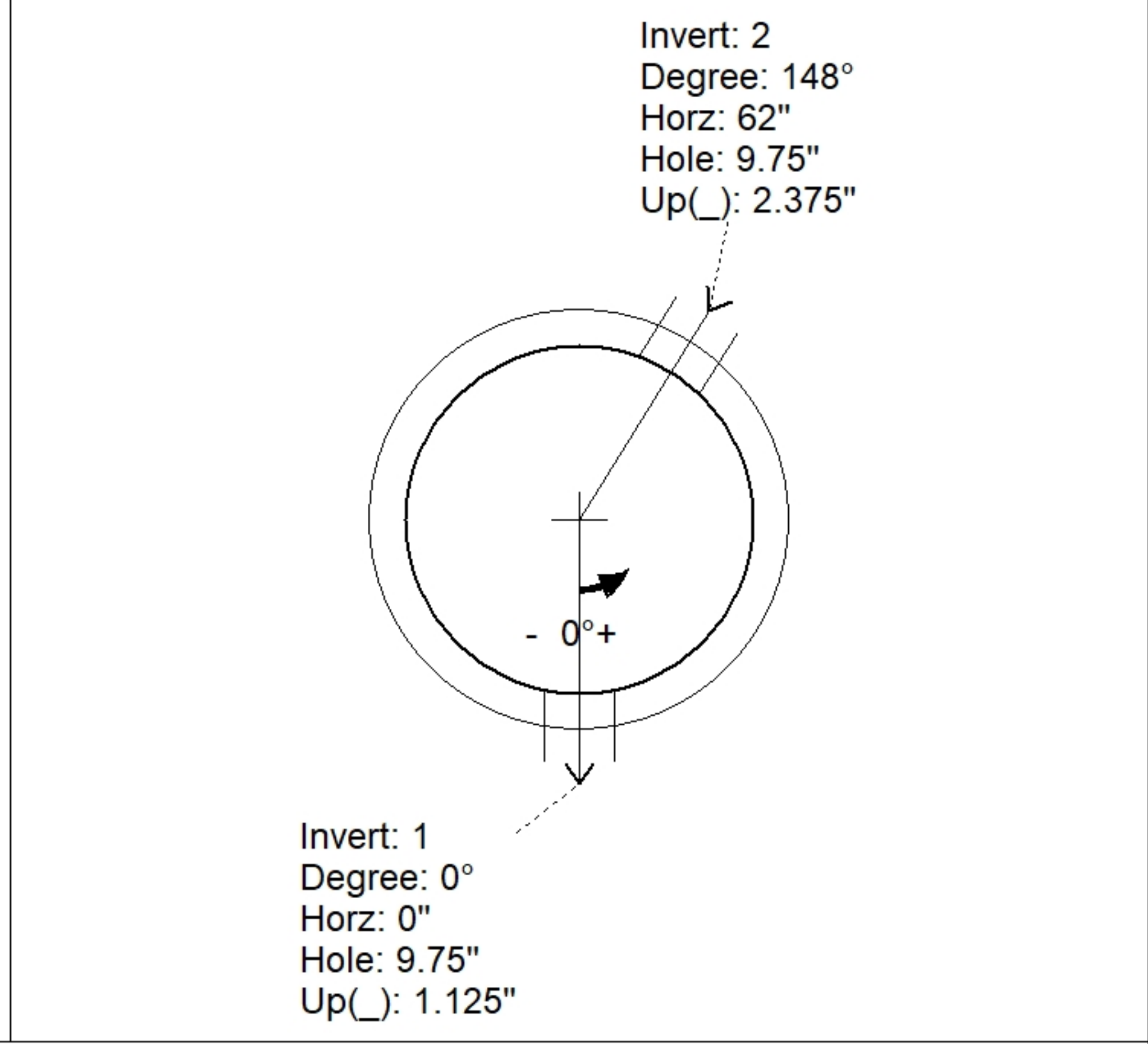
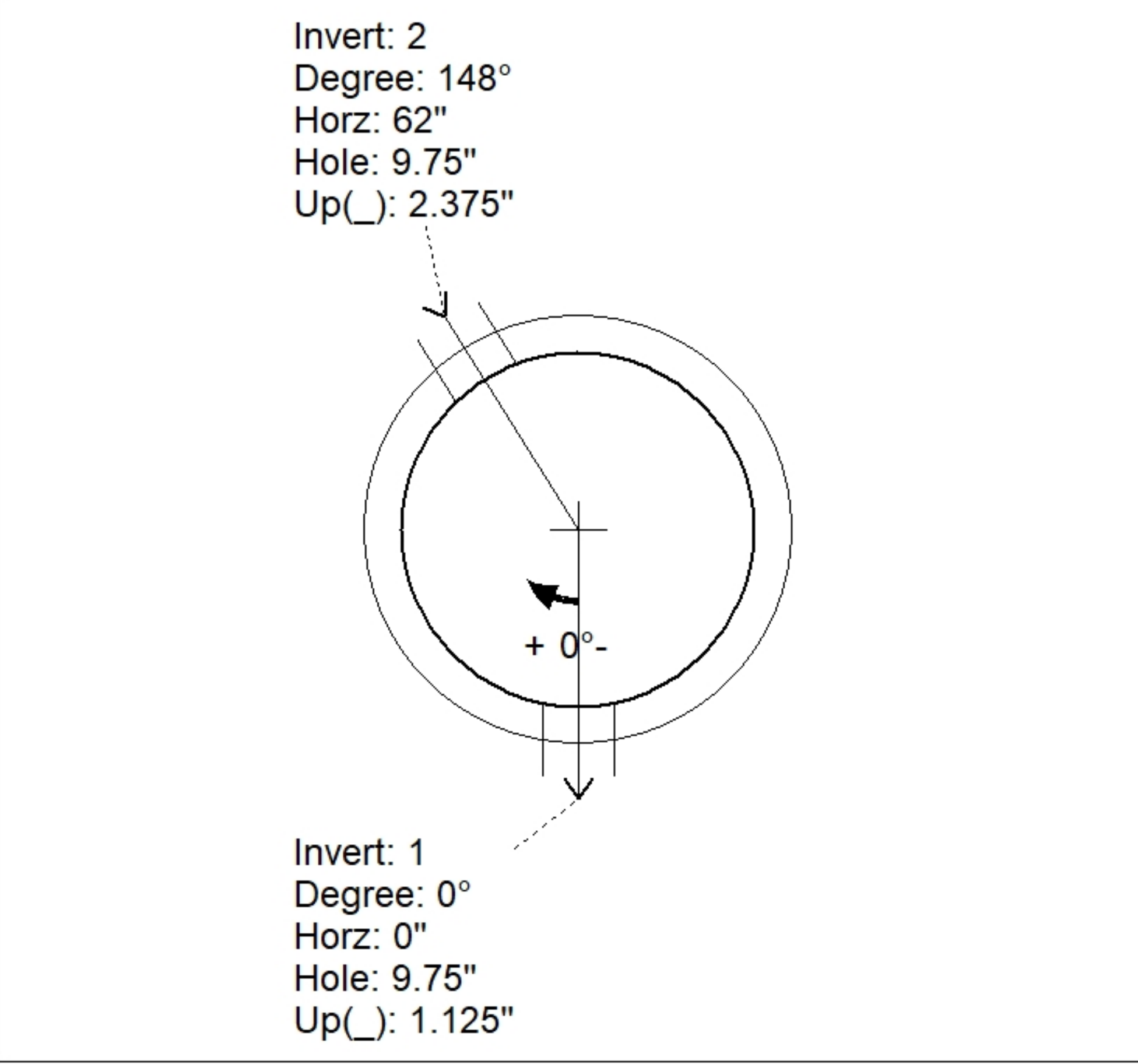
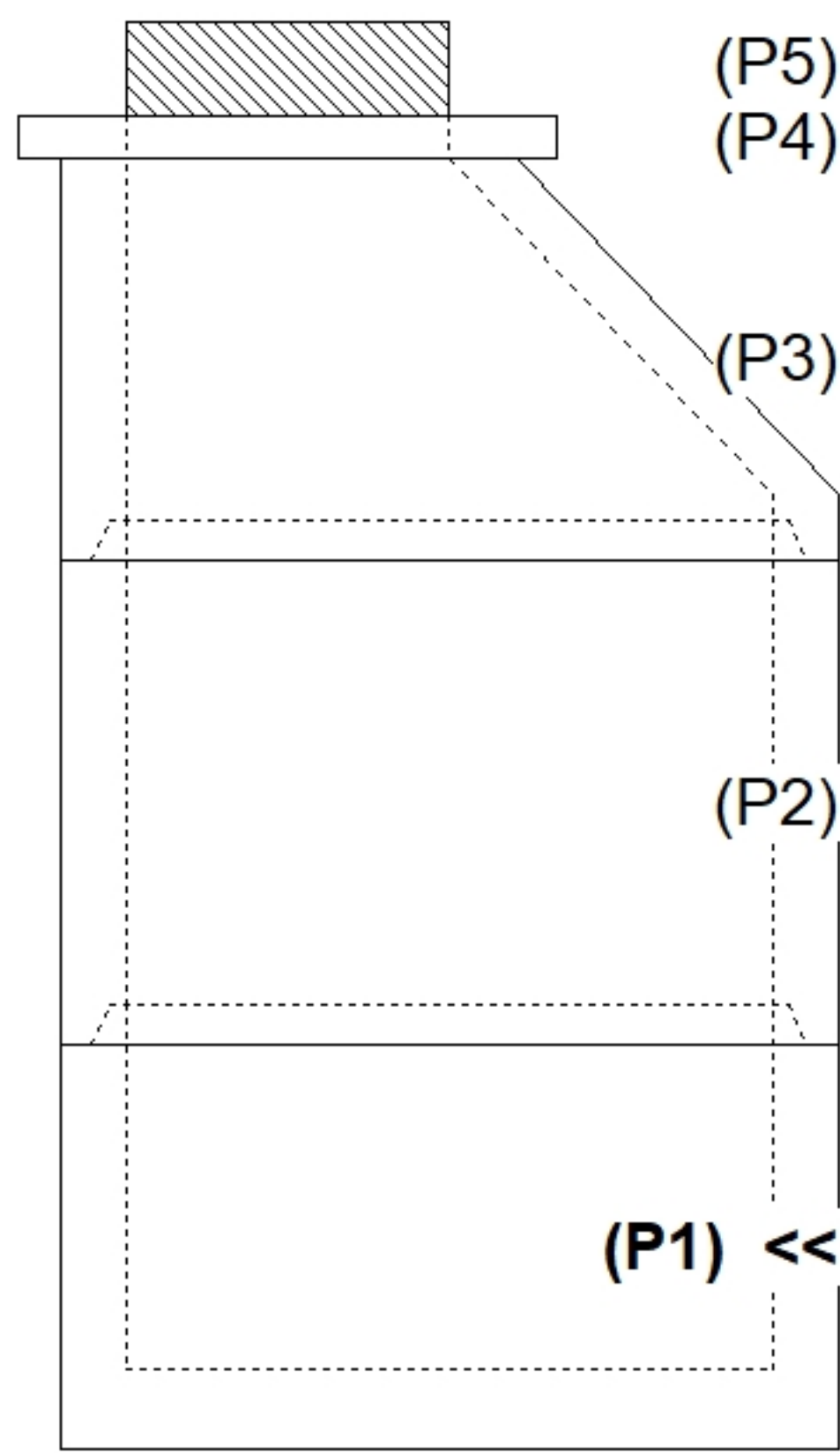

INSIDE WALL DIMENSIONS

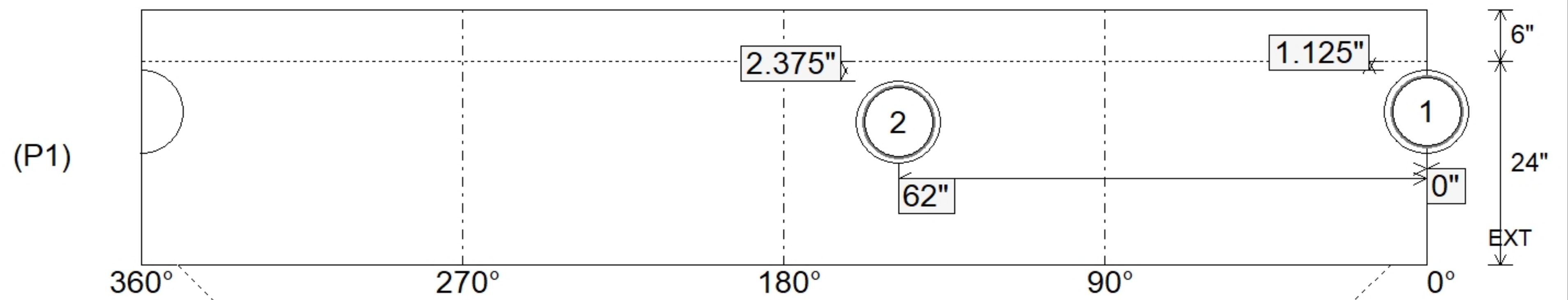

Coating (Int): Coating (Ext):	Seam Up: Tongue Seam Dn: n/a	Wall Thickness: 5" Floor Height: 6"	Height (Int): 24" Height (Ext): 30"	Weight (Net): 2944 lb Volume (Net): 0.75cu.yd
----------------------------------	---------------------------------	--	--	--

Structure ID: SSMH G4

P1 A MH048BA24

MH BASE T/n

P5) 24" - CASTING HEIGHT - 7" P4) 24" - GRADE RING F/F - 3" P3) 48" - ECC CONE w/ 24" HOLE F/G - 30" P2) 48" - MH RISER T/G - 36" P1) 48" - MH BASE T/n - 24" 1) 48" - MH INVERT CHANNEL - FULL HEIGHT 1) JOINT WRAP - 0.065"x6"x50' CONSEAL CS212 1) JOINT WRAP PRIMER - CONSEAL CS-75 (1 gal.) 1) CASTING - HOE MC-315 F/C Sanitary 2) 48" - DBL 1"x14.5' Butyl (2x) 2) A-Lok - 0285	0 lb 202 lb 2050 lb 2515 lb 2944 lb 1440 lb 0 lb 0 lb 258 lb 0 lb 2 lb <hr style="width: 50px; margin-left: 0;"/> Structure Total: 9411 lb
--	---

Structure Notes:

1. PER ASTM C478 SPECIFICATIONS.
2. CONCRETE = 4,000 PSI AT 28 DAYS.
3. MC-315 "SANITARY" BY ICAST
4. REINFORCING PER ASTM A615 (GRADE 60).
 - CONE (As .12)
 - RISER/WALLS (As .12)
 - FLOOR (As .31) #5 BARS AT 12" C.C.E.W.
5. NO STEPS

Rim: 899.06' Rim to Invert: 8.19' Slack: 0.28" Sump: 2" Step Position: 270°

Position	Elev	Angle	Ext. (cw)	Pipe	Pipe OD	Connector	Hole	Horz Size	Up ()	Offset
Invert 1	890.87'	0°	0"	8" PVC SDR35	8.5"	A-Lok 0285	9.75"	9.818"	1.125"	0"
Invert 2	890.97'	148°	74.875"	8" PVC SDR35	8.5"	A-Lok 0285	9.75"	9.818"	2.375"	0"
Invert 3										
Invert 4										
Invert 5										
Invert 6										
Invert 7										
Invert 8										

RIGHT-SIDE UP VIEW (int. dimensions)

UPSIDE-DOWN VIEW (int. dimensions)

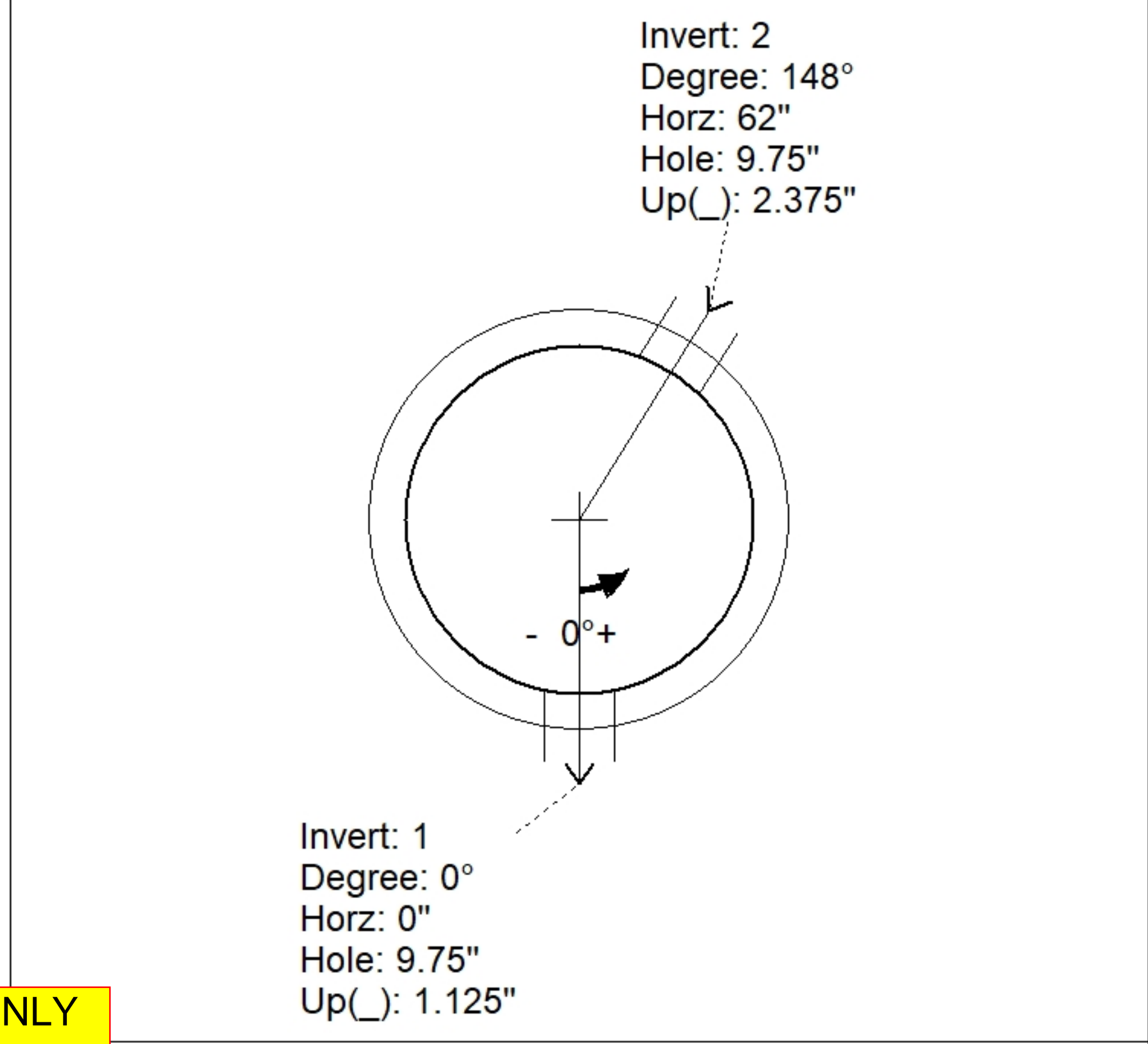
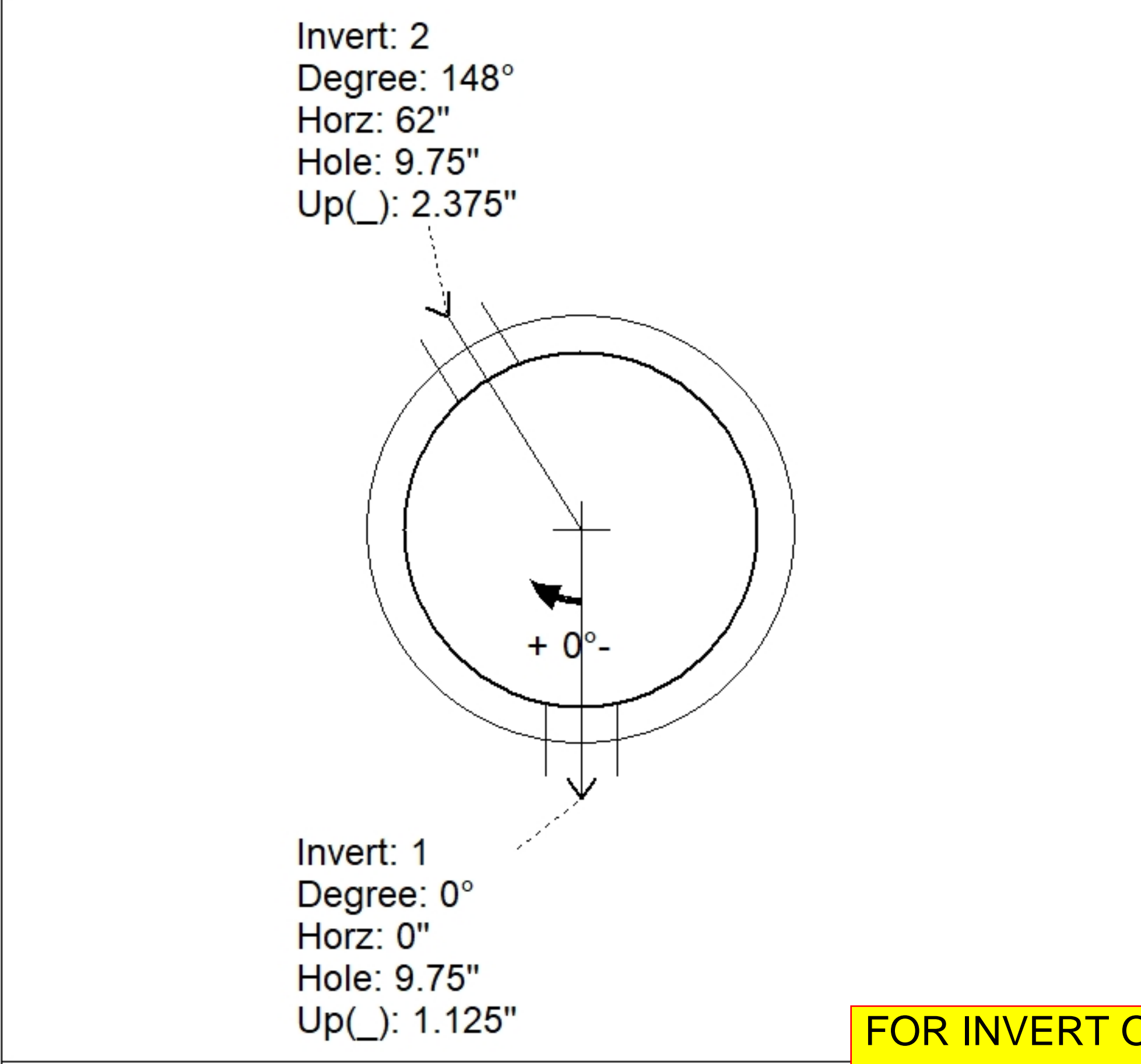
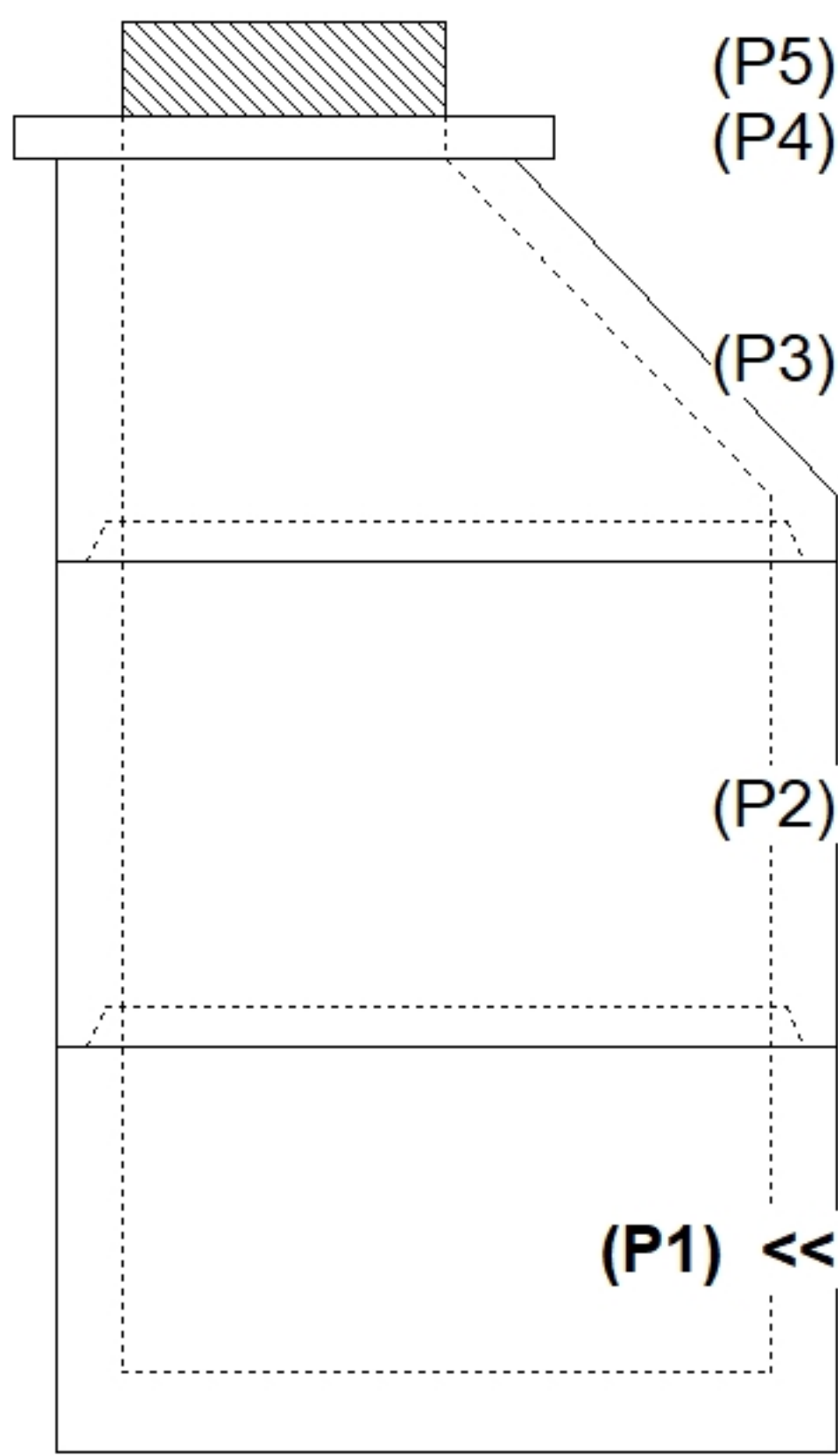

FOR INVERT ONLY

INSIDE WALL DIMENSIONS

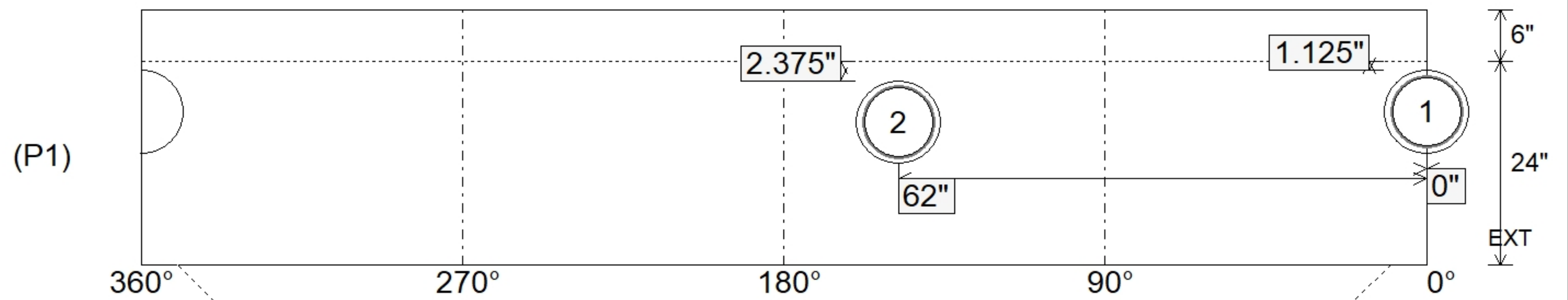

Coating (Int):	Seam Up: Tongue	Wall Thickness: 5"	Height (Int): 24"
Coating (Ext):	Seam Dn: n/a	Floor Height: 6"	Height (Ext): 30"
		Weight (Net): 2944 lb	
		Volume (Net): 0.75cu.yd	