

Job Name: 25-3292 Arbor View Sec. 2	Plant: Beaver Dam	Tech: C.Russ	
Job Location: Eminence, KY	10/21/2025 9:21:26 AM	PC: J.Jarvis	
Contractor: Core & Main LP (Lou)			

Structure ID: SSMH G3

P1 MH048BA42

MH BASE T/n

P3) 24" - CASTING HEIGHT - 7"	0 lb
P2) 48" - MH FLAT TOP w/ 24" ECC Hole F/G - 12"	1561 lb
P1) 48" - MH BASE T/n - 42"	4201 lb
1) 48" - MH INVERT CHANNEL - FULL HEIGHT	1440 lb
1) JOINT WRAP - 0.065"x6"x50' CONSEAL CS212	0 lb
1) JOINT WRAP PRIMER - CONSEAL CS-75 (1 gal.)	0 lb
1) CASTING - HOE MC-315 F/C Sanitary	258 lb
1) 48" - DBL 1"x14.5' Butyl (2x)	0 lb
2) A-Lok - 0285	2 lb
Structure Total:	7462 lb

Structure Notes:

- PER ASTM C478 SPECIFICATIONS.
- CONCRETE = 4,000 PSI AT 28 DAYS.
- MC-315 "SANITARY" BY ICAST
- REINFORCING PER ASTM A615 (GRADE 60).
- CONE (As .12)
- RISER/WALLS (As .12)
- FLOOR (As .31) #5 BARS AT 12" C.C.E.W.
- NO STEPS

Rim: 905.27' Rim to Invert: 4.94' Slack: 0.28" Sump: 2" Step Position: 270°

Position	Elev	Angle	Ext. (cw)	Pipe	Pipe OD	Connector	Hole	Horz Size	Up ()	Offset
Invert 1	900.33'	0°	0"	8" PVC SDR35	8.5"	A-Lok 0285	9.75"	9.818"	1.125"	0"
Invert 2	900.43'	175°	88.625"	8" PVC SDR35	8.5"	A-Lok 0285	9.75"	9.818"	2.375"	0"
Invert 3										
Invert 4										
Invert 5										
Invert 6										
Invert 7										
Invert 8										

RIGHT-SIDE UP VIEW (int. dimensions)

UPSIDE-DOWN VIEW (int. dimensions)

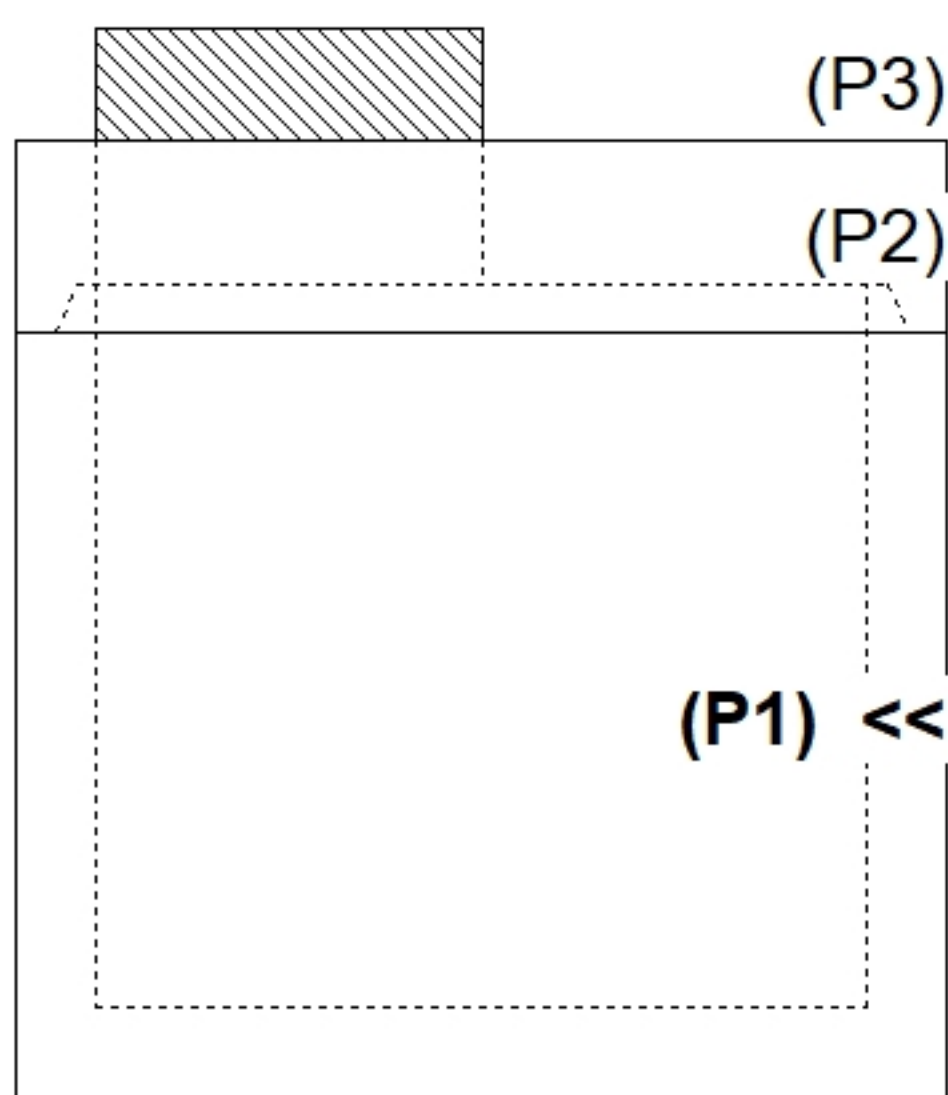
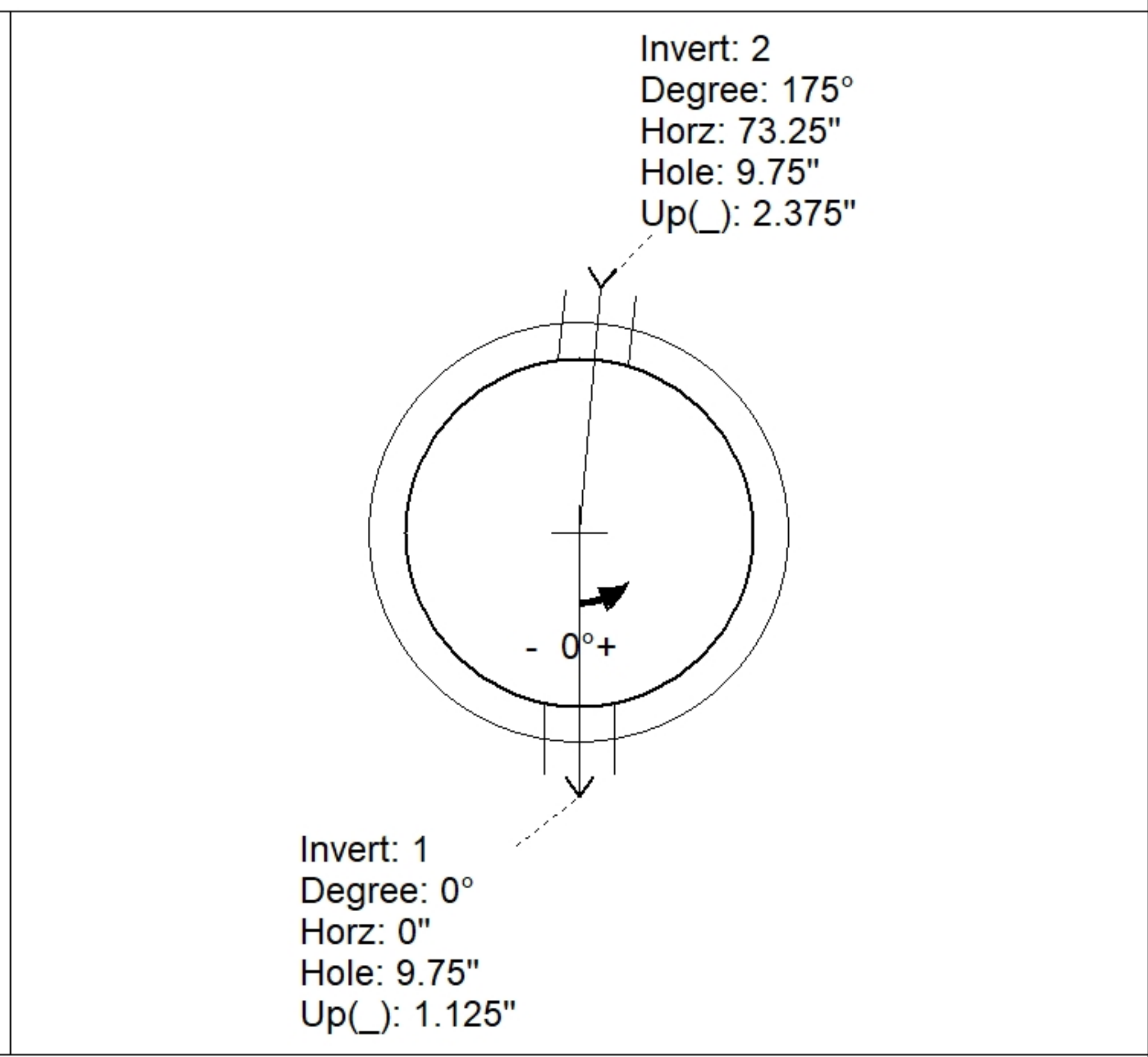
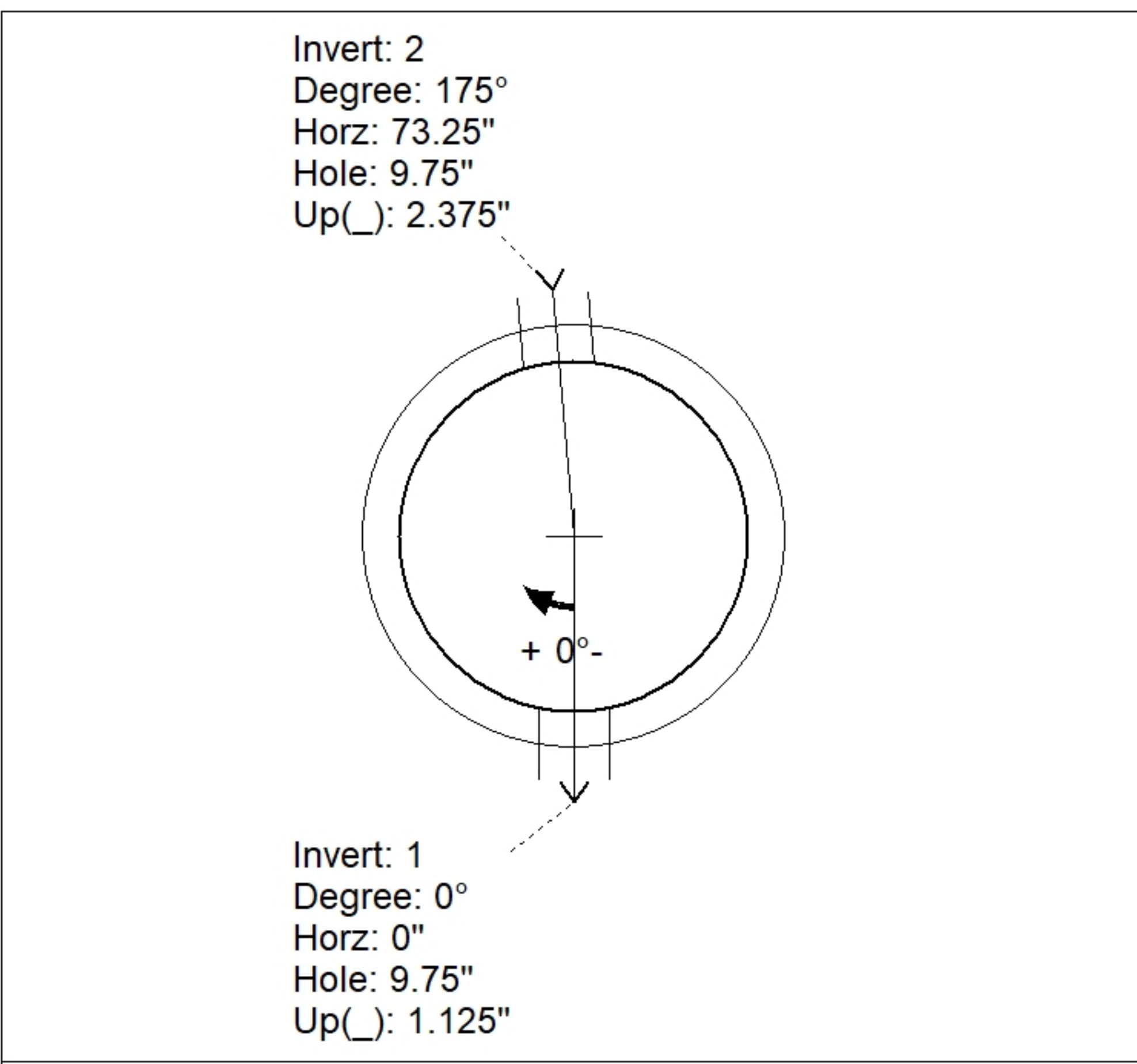

INSIDE WALL DIMENSIONS

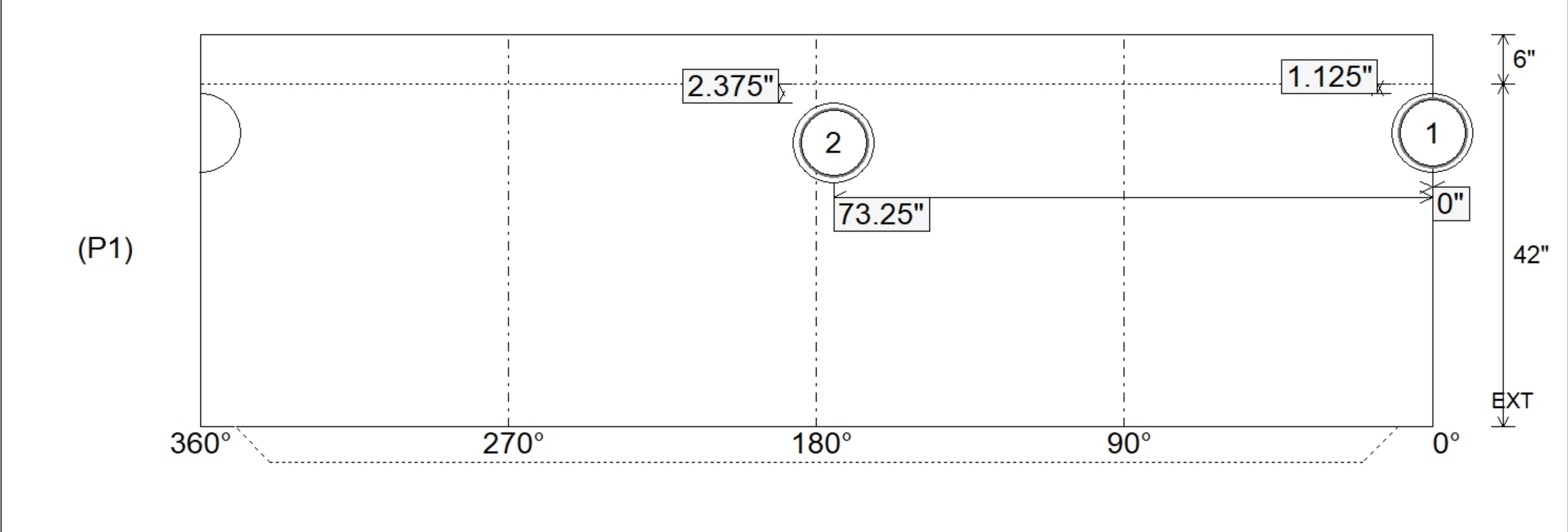

Coating (Int):	Seam Up: Tongue	Wall Thickness: 5"	Height (Int): 42"	Weight (Net): 4201 lb
Coating (Ext):	Seam Dn: n/a	Floor Height: 6"	Height (Ext): 48"	Volume (Net): 1.07cu.yd

Job Name: 25-3292 Arbor View Sec. 2	Plant: Beaver Dam	Tech: C.Russ	
Job Location: Eminence, KY	10/21/2025 9:21:26 AM	PC: J.Jarvis	
Contractor: Core & Main LP (Lou)			

Structure ID: SSMH G3

P1 A MH048BA42

MH BASE T/n

P3) 24" - CASTING HEIGHT - 7"	0 lb
P2) 48" - MH FLAT TOP w/ 24" ECC Hole F/G - 12"	1561 lb
P1) 48" - MH BASE T/n - 42"	4201 lb
1) 48" - MH INVERT CHANNEL - FULL HEIGHT	1440 lb
1) JOINT WRAP - 0.065"x6"x50' CONSEAL CS212	0 lb
1) JOINT WRAP PRIMER - CONSEAL CS-75 (1 gal.)	0 lb
1) CASTING - HOE MC-315 F/C Sanitary	258 lb
1) 48" - DBL 1"x14.5' Butyl (2x)	0 lb
2) A-Lok - 0285	2 lb
Structure Total:	7462 lb

Structure Notes:

- PER ASTM C478 SPECIFICATIONS.
- CONCRETE = 4,000 PSI AT 28 DAYS.
- MC-315 "SANITARY" BY ICAST
- REINFORCING PER ASTM A615 (GRADE 60).
- CONE (As .12)
- RISER/WALLS (As .12)
- FLOOR (As .31) #5 BARS AT 12" C.C.E.W.
- NO STEPS

Rim: 905.27' Rim to Invert: 4.94' Slack: 0.28" Sump: 2" Step Position: 270°

Position	Elev	Angle	Ext. (cw)	Pipe	Pipe OD	Connector	Hole	Horz Size	Up ()	Offset
Invert 1	900.33'	0°	0"	8" PVC SDR35	8.5"	A-Lok 0285	9.75"	9.818"	1.125"	0"
Invert 2	900.43'	175°	88.625"	8" PVC SDR35	8.5"	A-Lok 0285	9.75"	9.818"	2.375"	0"
Invert 3										
Invert 4										
Invert 5										
Invert 6										
Invert 7										
Invert 8										

RIGHT-SIDE UP VIEW (int. dimensions)

UPSIDE-DOWN VIEW (int. dimensions)

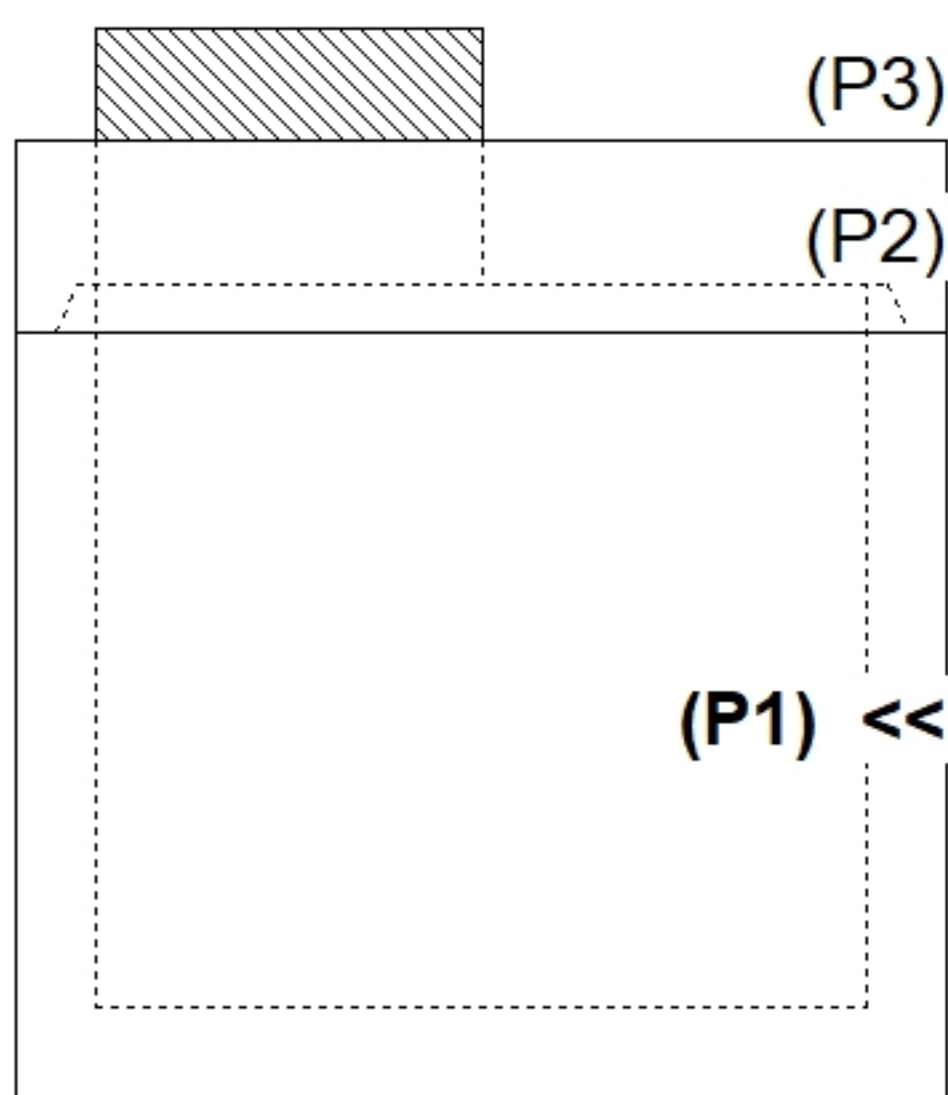
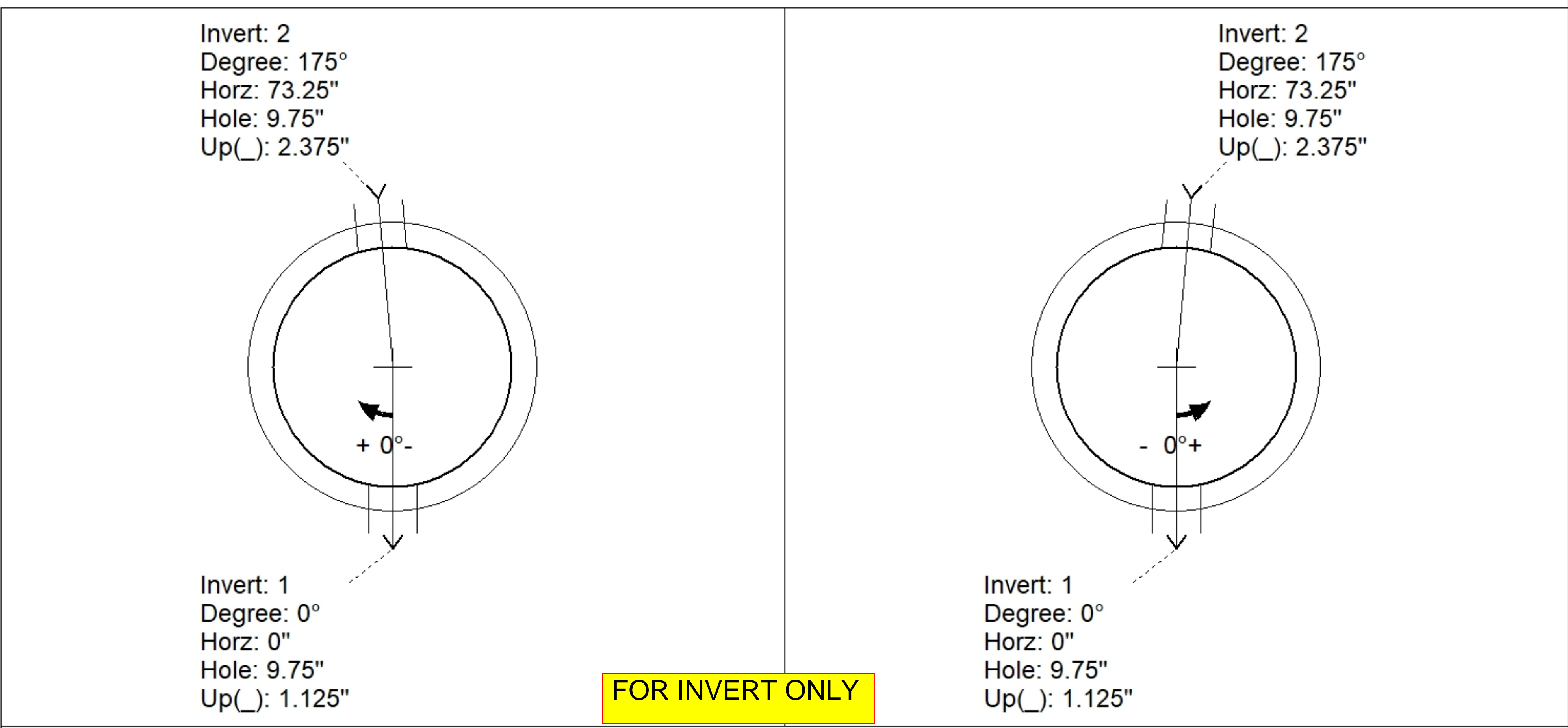

INSIDE WALL DIMENSIONS

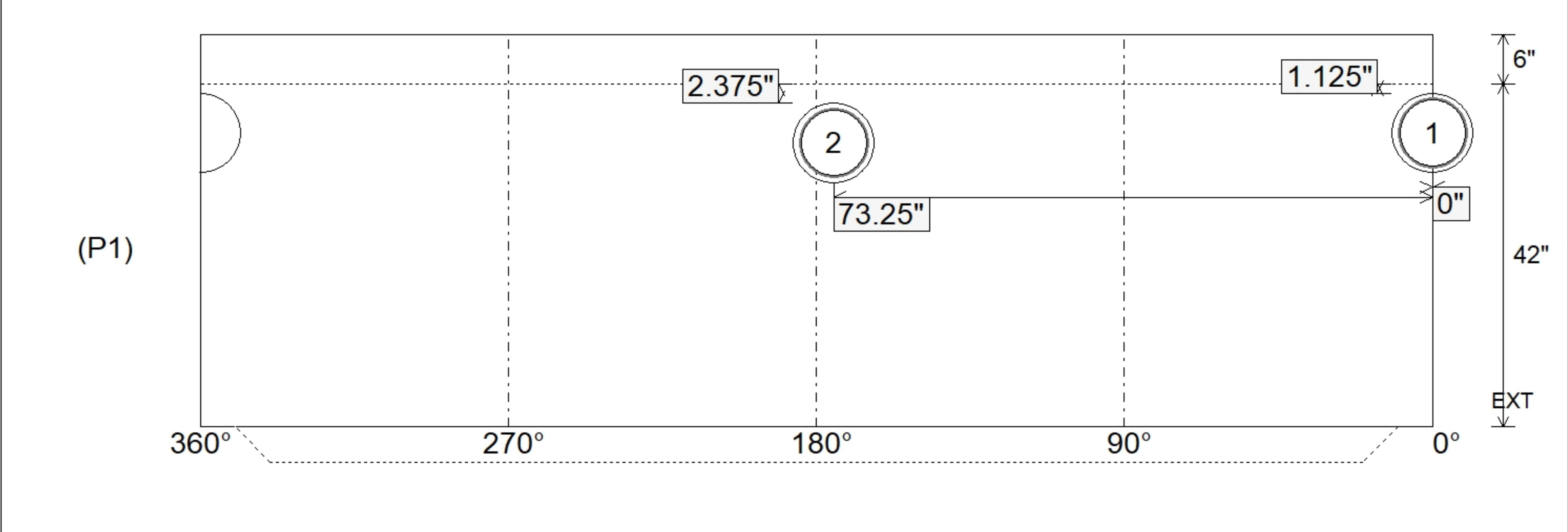

Coating (Int):	Seam Up: Tongue	Wall Thickness: 5"	Height (Int): 42"	Weight (Net): 4201 lb
Coating (Ext):	Seam Dn: n/a	Floor Height: 6"	Height (Ext): 48"	Volume (Net): 1.07cu.yd