

**Structure ID: SSMH G2**

**P1 MH048BA24**

**MH BASE T/n**

P3) 24" - CASTING HEIGHT - 7" P2) 48" - ECC CONE w/ 24" HOLE F/G - 30" P1) 48" - MH BASE T/n - 24" 1) 48" - MH INVERT CHANNEL - FULL HEIGHT 1) JOINT WRAP - 0.065"x6"x50' CONSEAL CS212 1) JOINT WRAP PRIMER - CONSEAL CS-75 (1 gal.) 1) CASTING - HOE MC-315 F/C Sanitary 1) 48" - DBL 1"x14.5' Butyl (2x) 2) A-Lok - 0285	0 lb 2050 lb 2944 lb 1440 lb 0 lb 0 lb 258 lb 0 lb 2 lb ----- Structure Total: 6694 lb
---	--

**Structure Notes:**

1. PER ASTM C478 SPECIFICATIONS.
2. CONCRETE = 4,000 PSI AT 28 DAYS.
3. MC-315 "SANITARY" BY ICAST
4. REINFORCING PER ASTM A615 (GRADE 60).  
 - CONE (As .12)  
 - RISER/WALLS (As .12)  
 - FLOOR (As .31) #5 BARS AT 12" C.C.E.W.
5. NO STEPS

Rim: 911.79'    Rim to Invert: 5.14'    Slack: 2.68"    Sump: 2"    Step Position: 270°

Position	Elev	Angle	Ext. (cw)	Pipe	Pipe OD	Connector	Hole	Horz Size	Up ( )	Offset
Invert 1	906.65'	0°	0"	8" PVC SDR35	8.5"	A-Lok 0285	9.75"	9.818"	1.125"	0"
Invert 2	906.75'	138°	69.875"	8" PVC SDR35	8.5"	A-Lok 0285	9.75"	9.818"	2.375"	0"
Invert 3										
Invert 4										
Invert 5										
Invert 6										
Invert 7										
Invert 8										

RIGHT-SIDE UP VIEW (int. dimensions)

UPSIDE-DOWN VIEW (int. dimensions)

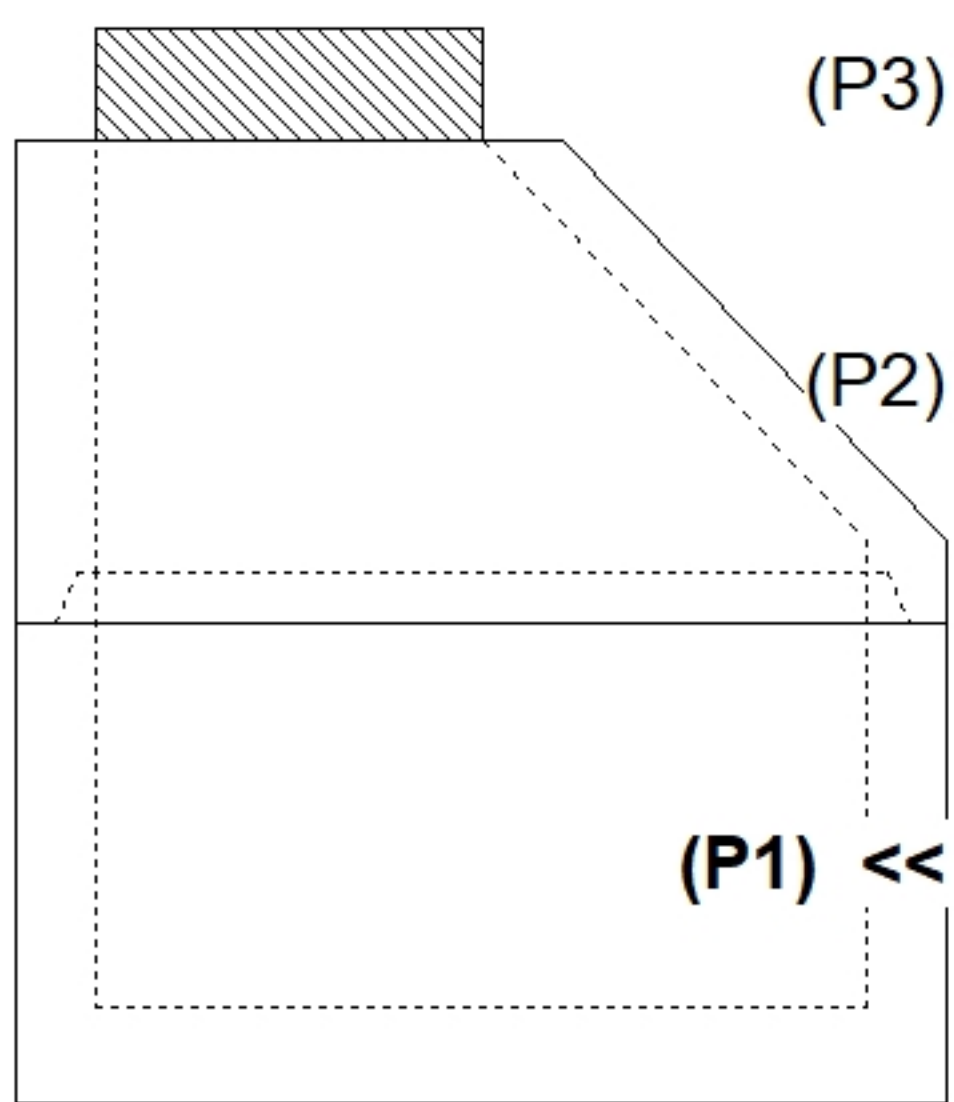
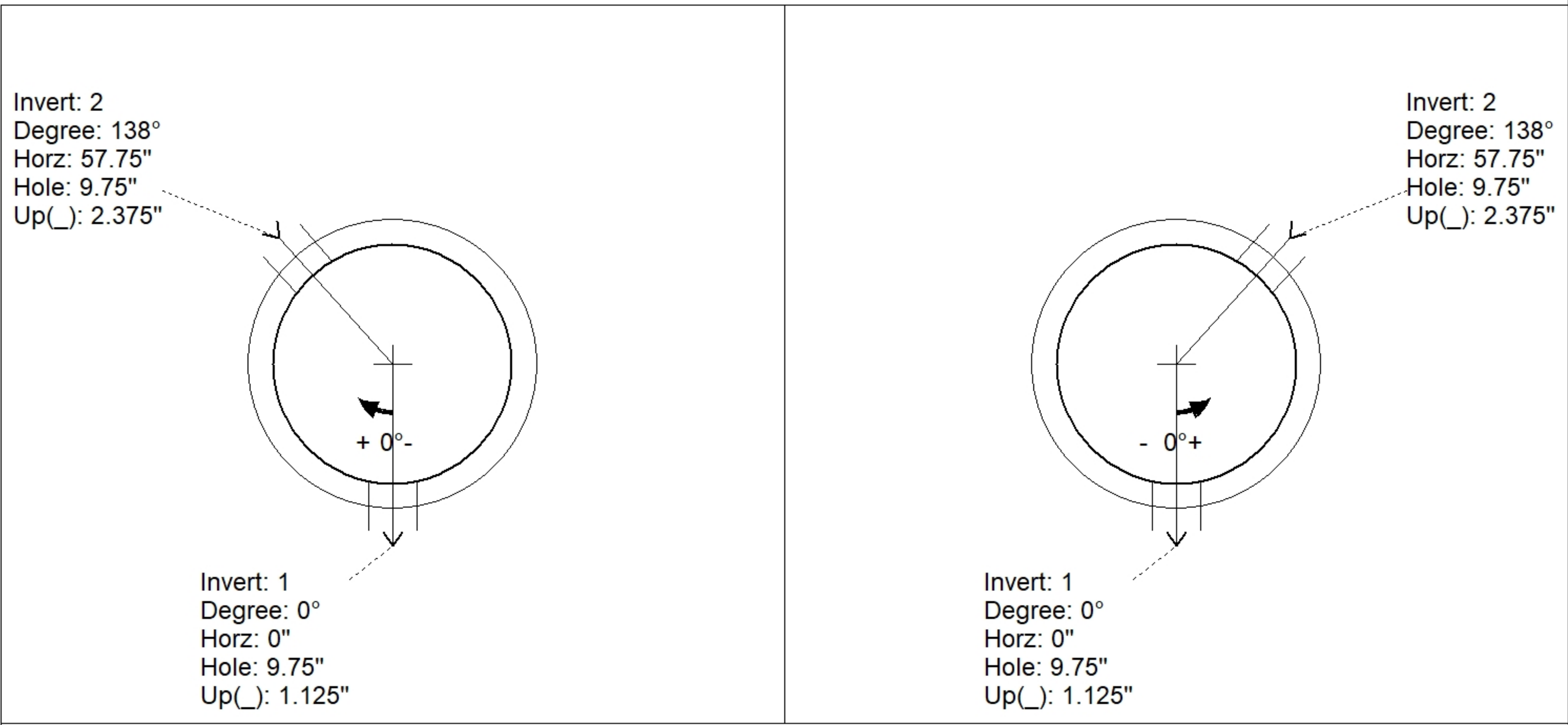

INSIDE WALL DIMENSIONS

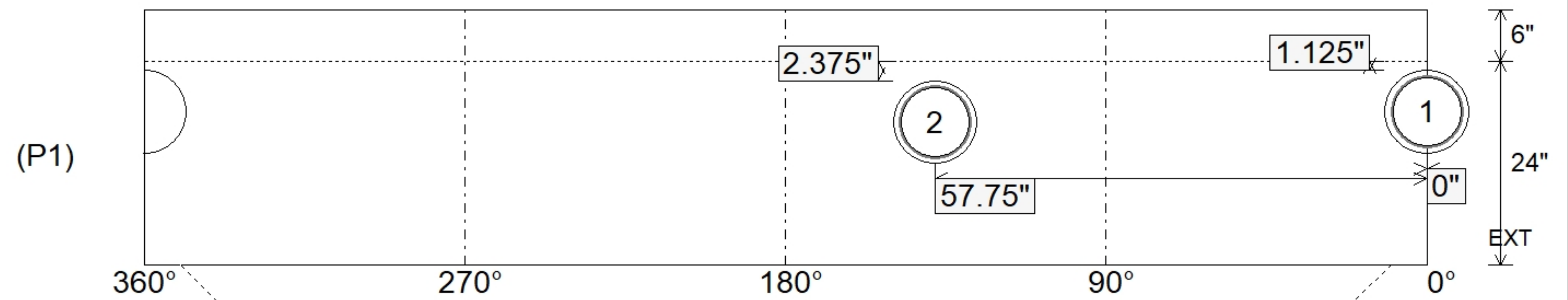

Coating (Int): Coating (Ext):	Seam Up: Tongue Seam Dn: n/a	Wall Thickness: 5" Floor Height: 6"	Height (Int): 24" Height (Ext): 30"	Weight (Net): 2944 lb Volume (Net): 0.75cu.yd
----------------------------------	---------------------------------	--	--	--

**Structure ID: SSMH G2**

**P1A MH048BA24**

**MH BASE T/n**

- P3) 24" - CASTING HEIGHT - 7"
- P2) 48" - ECC CONE w/ 24" HOLE F/G - 30"
- P1) 48" - MH BASE T/n - 24"
- 1) 48" - MH INVERT CHANNEL - FULL HEIGHT
- 1) JOINT WRAP - 0.065"x6"x50' CONSEAL CS212
- 1) JOINT WRAP PRIMER - CONSEAL CS-75 (1 gal.)
- 1) CASTING - HOE MC-315 F/C Sanitary
- 1) 48" - DBL 1"x14.5' Butyl (2x)
- 2) A-Lok - 0285

0 lb  
 2050 lb  
 2944 lb  
 1440 lb  
 0 lb  
 0 lb  
 258 lb  
 0 lb  
 2 lb  
 -----  
 Structure Total: 6694 lb

Structure Notes:  
 1. PER ASTM C478 SPECIFICATIONS.  
 2. CONCRETE = 4,000 PSI AT 28 DAYS.  
 3. MC-315 "SANITARY" BY ICAST  
 4. REINFORCING PER ASTM A615 (GRADE 60).  
 - CONE (As .12)  
 - RISER/WALLS (As .12)  
 - FLOOR (As .31) #5 BARS AT 12" C.C.E.W.  
 5. NO STEPS

Rim: 911.79'    Rim to Invert: 5.14'    Slack: 2.68"    Sump: 2"    Step Position: 270°

Position	Elev	Angle	Ext. (cw)	Pipe	Pipe OD	Connector	Hole	Horz Size	Up ( )	Offset
Invert 1	906.65'	0°	0"	8" PVC SDR35	8.5"	A-Lok 0285	9.75"	9.818"	1.125"	0"
Invert 2	906.75'	138°	69.875"	8" PVC SDR35	8.5"	A-Lok 0285	9.75"	9.818"	2.375"	0"
Invert 3										
Invert 4										
Invert 5										
Invert 6										
Invert 7										
Invert 8										

RIGHT-SIDE UP VIEW (int. dimensions)

UPSIDE-DOWN VIEW (int. dimensions)

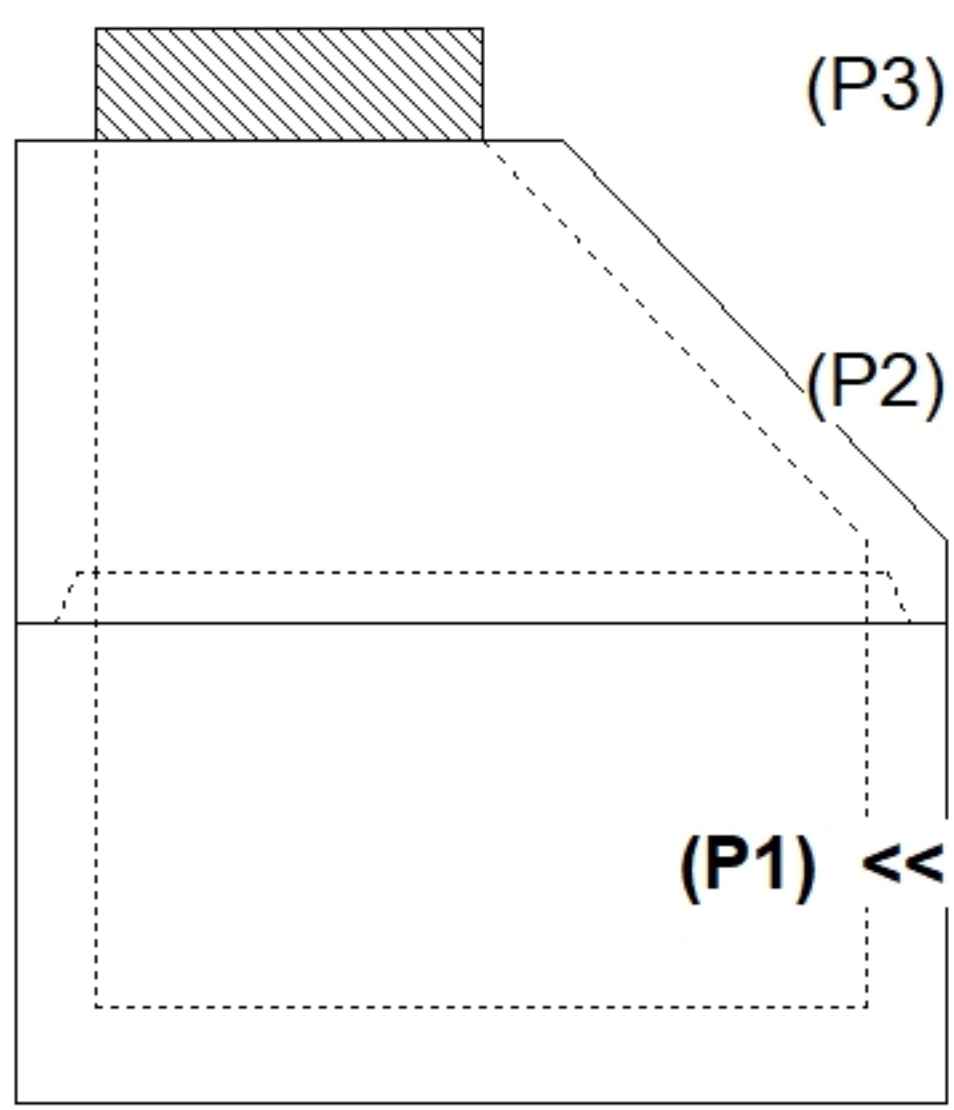
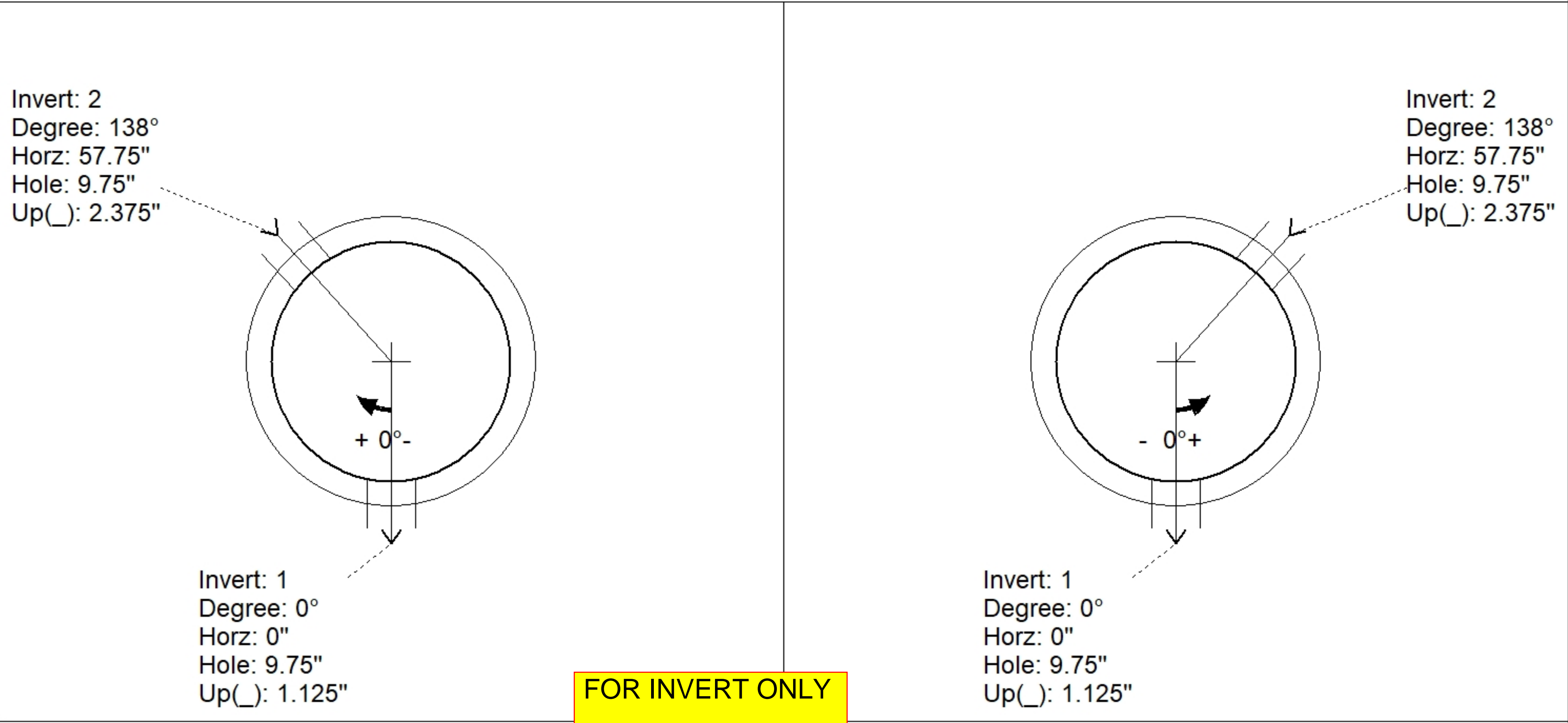

INSIDE WALL DIMENSIONS

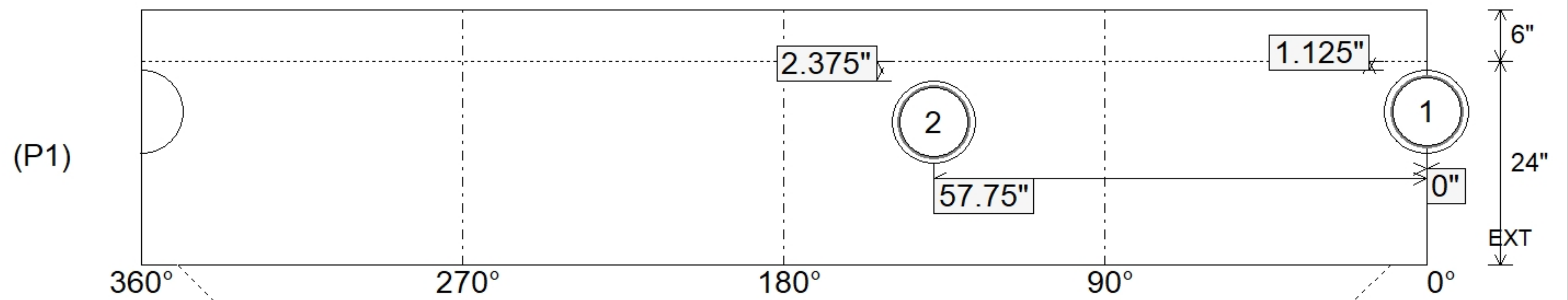

Coating (Int): Coating (Ext):	Seam Up: Tongue Seam Dn: n/a	Wall Thickness: 5" Floor Height: 6"	Height (Int): 24" Height (Ext): 30"	Weight (Net): 2944 lb Volume (Net): 0.75cu.yd
----------------------------------	---------------------------------	--	--	--