

Job Name: 25-3292 Arbor View Sec. 2	Plant: Beaver Dam	Tech: C.Russ	
Job Location: Eminence, KY Contractor: Core & Main LP (Lou)	10/21/2025 9:21:19 AM	PC: J.Jarvis	

**Structure ID: CBI-C1**

**P1 BX2436-08BVF**

**BOX BASE 8inW, 8inF, Variable Ht F/n**

- P2) 24" x 36" - CASTING HEIGHT - 6"
- P1) 24" x 36" - BOX BASE 8inW, 8inF, Variable Ht F/n - 32"
- 1) CASTING - HOE 525 LV SET (F/G/H)
- 1) 24" x 36" - SGL 1"x14.5' Butyl
- 1) Hole - 24"

0 lb  
4358 lb  
442 lb  
0 lb  
0 lb  
-----  
Structure Total: 4800 lb

- Structure Notes:
1. PER ASTM C913 SPECIFICATIONS.
  2. CONCRETE = 4,000 PSI AT 28 DAYS.
  3. NO INVERT CHANNEL.
  4. HOE 525 BY ICAST
  5. REINFORCING PER ASTM A615 (GRADE 60).  
- WALLS (As .12) #5 BARS AT 12" C.C.E.W.  
- FLOOR (As .12) #5 BARS AT 12" C.C.E.W.

Rim: 908.83'    Rim to Invert: 3.19'    Slack: 0.28"    Sump: 0"    Step Position:

Position	Elev	Angle	Ext. (cw)	Pipe	Pipe OD	Connector	Hole	Horz Size	Up (⌋)	Offset
Invert 1	905.64'	90°	26"	18" HDPE	21.2"	Hole 24	24"	24"	-1.625"	0"
Invert 2										
Invert 3										
Invert 4										
Invert 5										
Invert 6										
Invert 7										
Invert 8										

RIGHT-SIDE UP VIEW (int. dimensions)

UPSIDE-DOWN VIEW (int. dimensions)

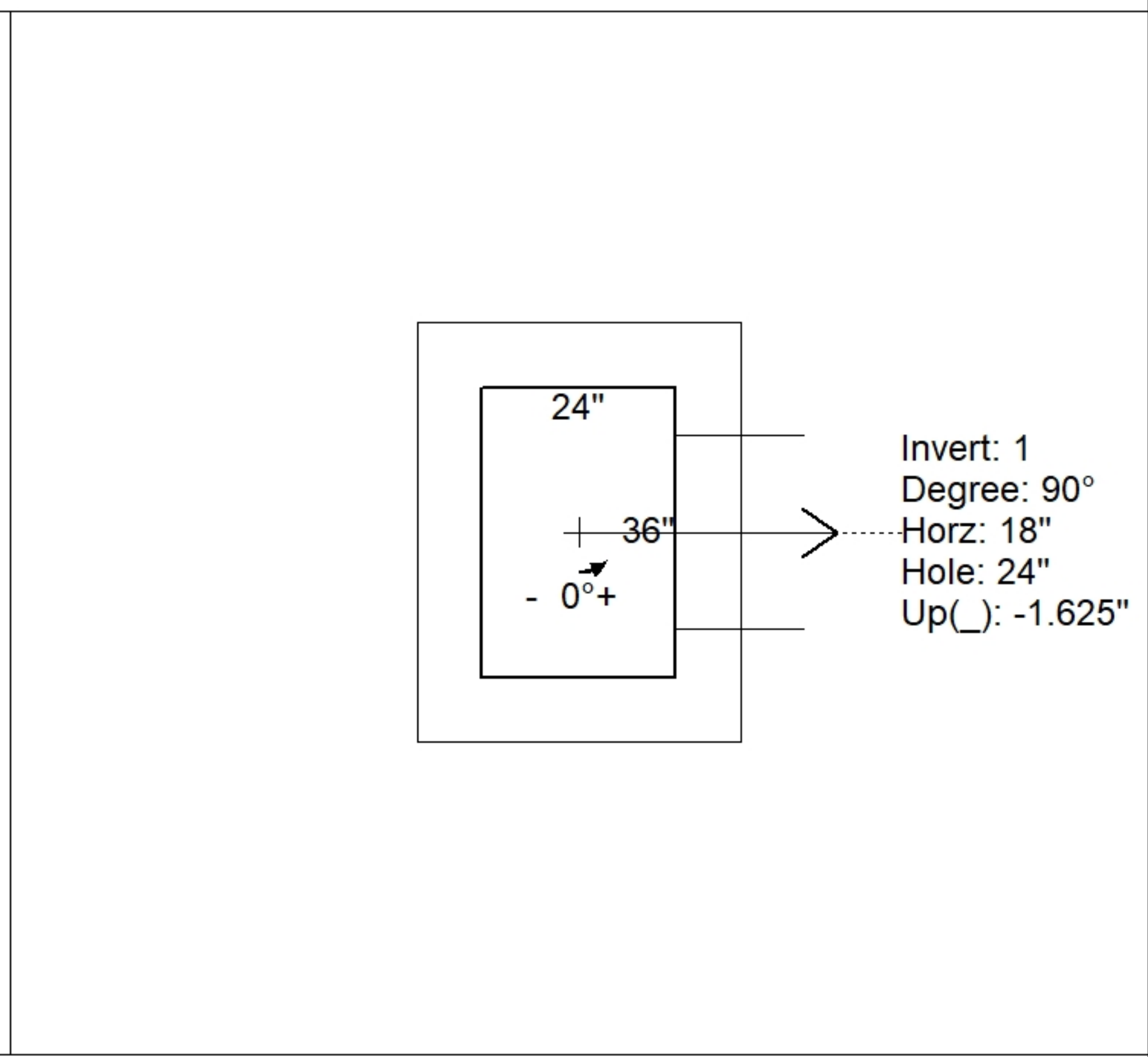
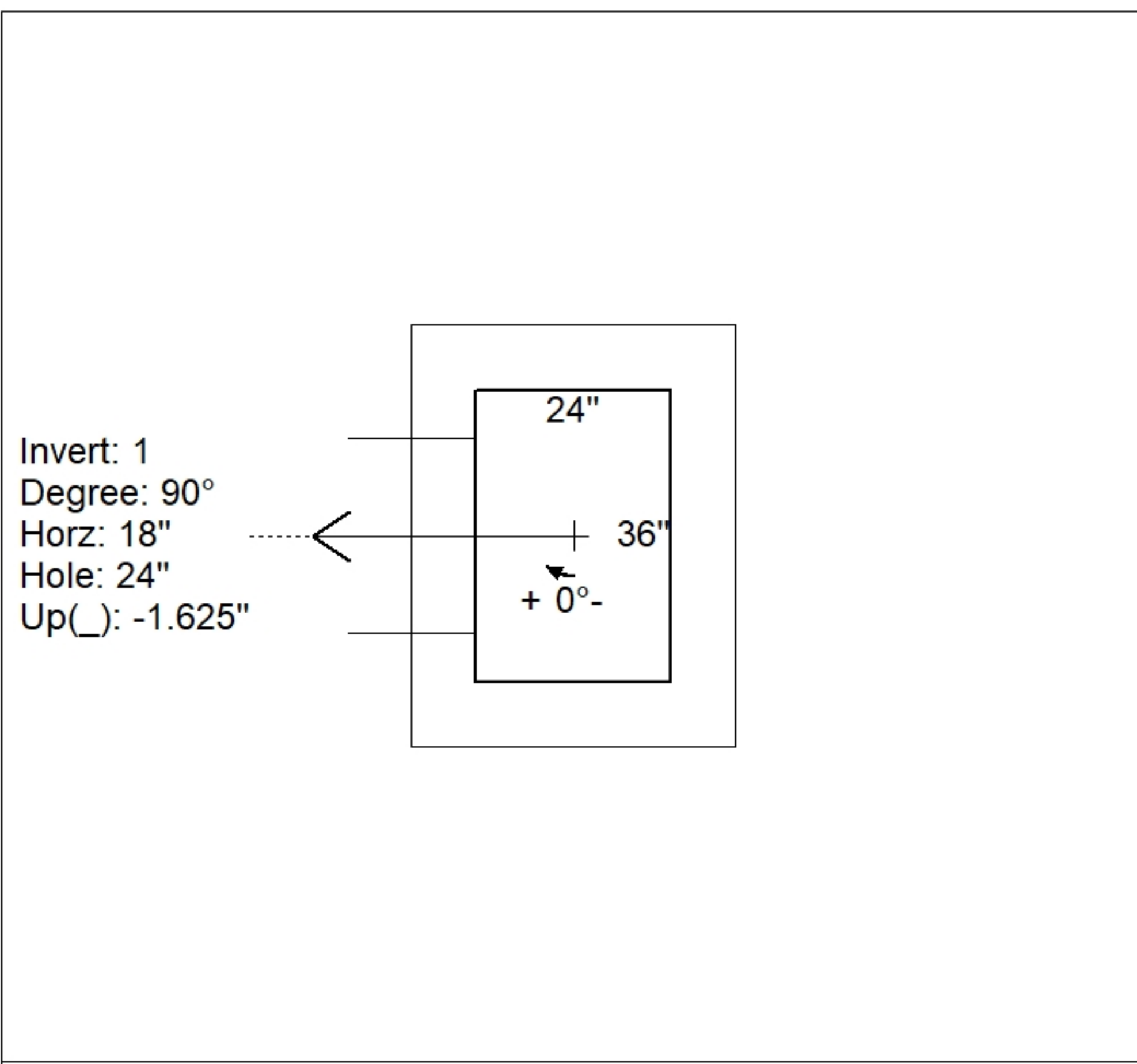
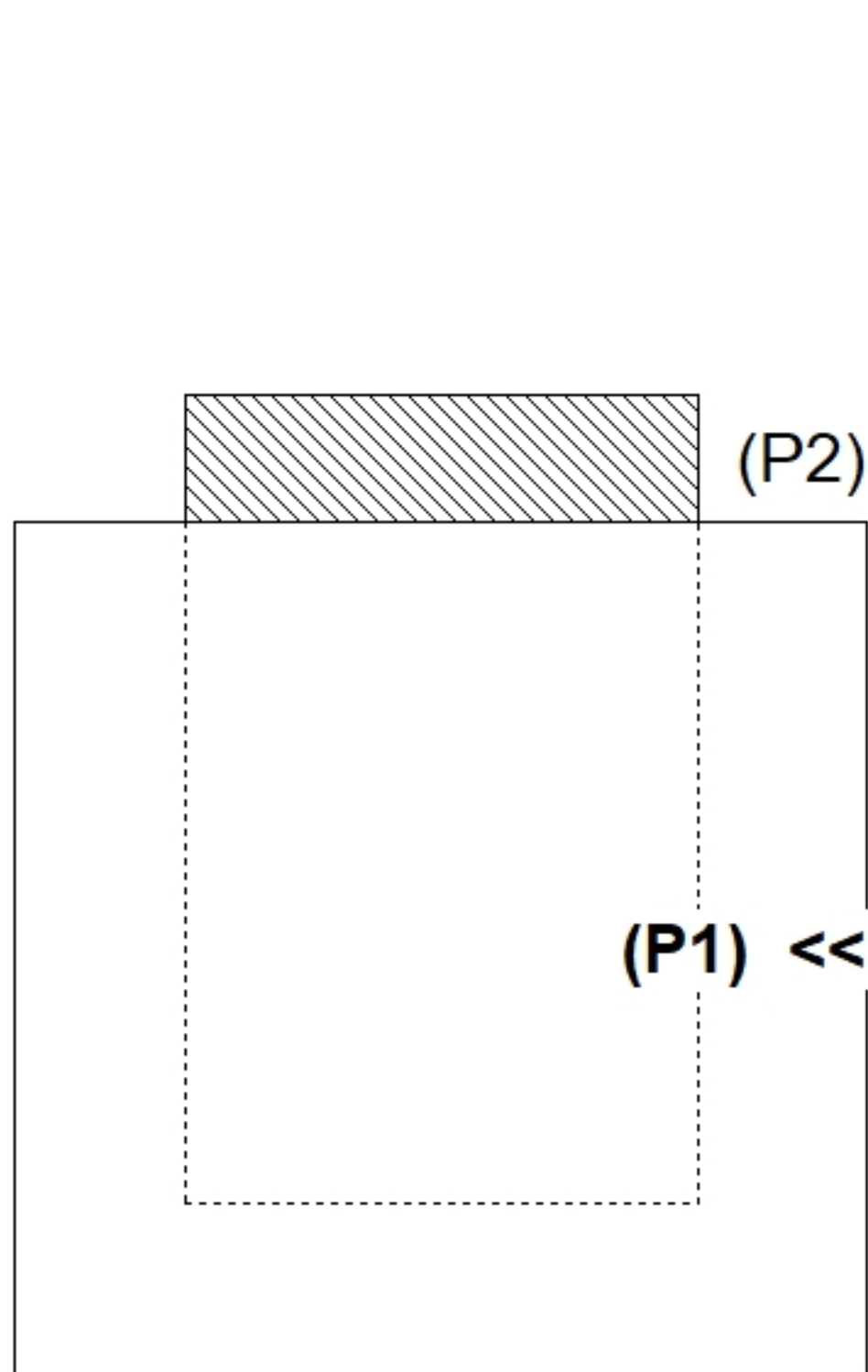

INSIDE WALL DIMENSIONS

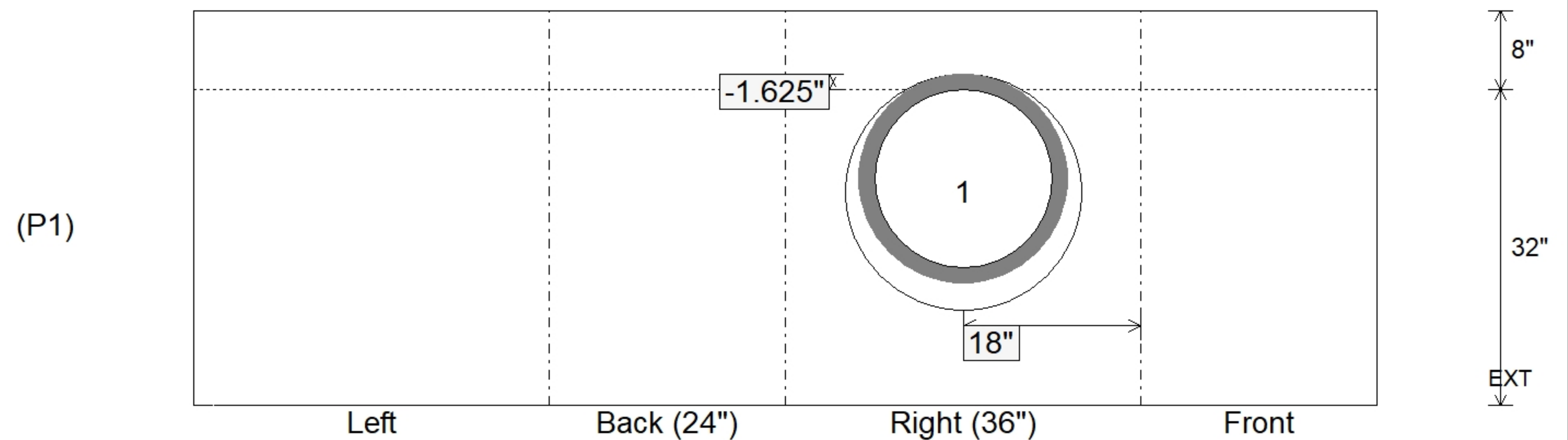

Coating (Int): Coating (Ext):	Seam Up: Flat Seam Dn: n/a	Wall Thickness: 8" Floor Height: 8"	Height (Int): 32" Height (Ext): 40"	Weight (Net): 4358 lb Volume (Net): 1.11cu.yd
----------------------------------	-------------------------------	--	--	--