

Job Name: 25-3292 Arbor View Sec. 2  
 Job Location: Eminence, KY  
 Contractor: Core & Main LP (Lou)

Plant: Beaver Dam

Tech: C.Russ

10/21/2025 9:22:27 AM

PC: J.Jarvis



**Structure ID: CBI-A6**

**P2 MH060LD13-24X36RECT**

**MH FLAT TOP w/24"x36" Hole F/G**

- P3) 24" x 36" - CASTING HEIGHT - 6"
- P2) 60" - MH FLAT TOP w/24"x36" Hole F/G - 13"
- P1) 60" - MH BASE Custom Ht T/n - 57"
- 1) CASTING - HOE 525 LV SET (F/G/H)
- 1) 60" - Conseal CS-102 1.00"
- 1) 24" x 36" - Conseal CS-102 1.00"
- 1) Hole - 38
- 1) Hole - 30
- 1) Hole - 24
- 5) MH Step ML-10-TDS-NCR - 10"

0 lb  
 3499 lb  
 7470 lb  
 442 lb  
 0 lb  
 0 lb  
 0 lb  
 0 lb  
 0 lb  
 0 lb  
 0 lb

Structure Total: 11411 lb

Structure Notes:

1. PER ASTM C478 SPECIFICATIONS.
2. CONCRETE = 4,000 PSI AT 28 DAYS.
3. HOE 525 BY ICAST
4. REINFORCING PER ASTM A615 (GRADE 60).  
 - TOP SLAB (As .62) #5 BARS AT 6" C.C.E.W..  
 - RISER/WALLS (As .18)  
 - FLOOR (As .37) #5 BARS AT 10" C.C.E.W.

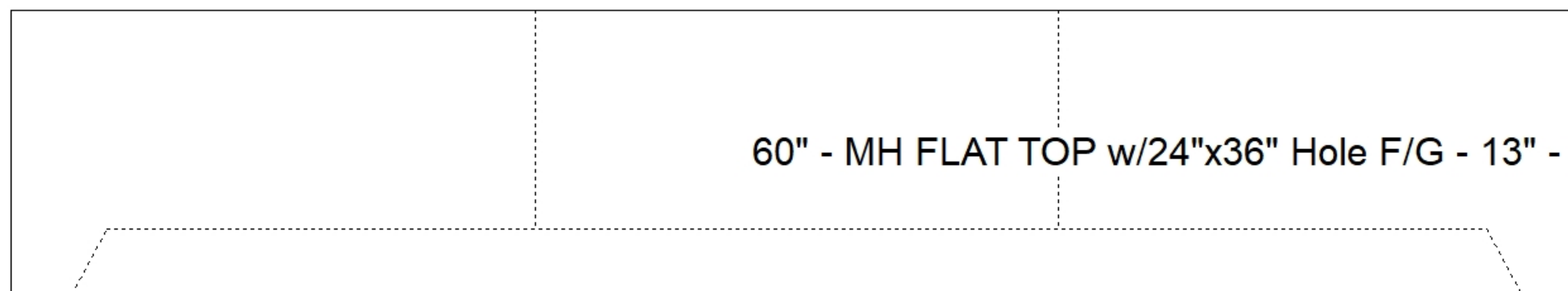
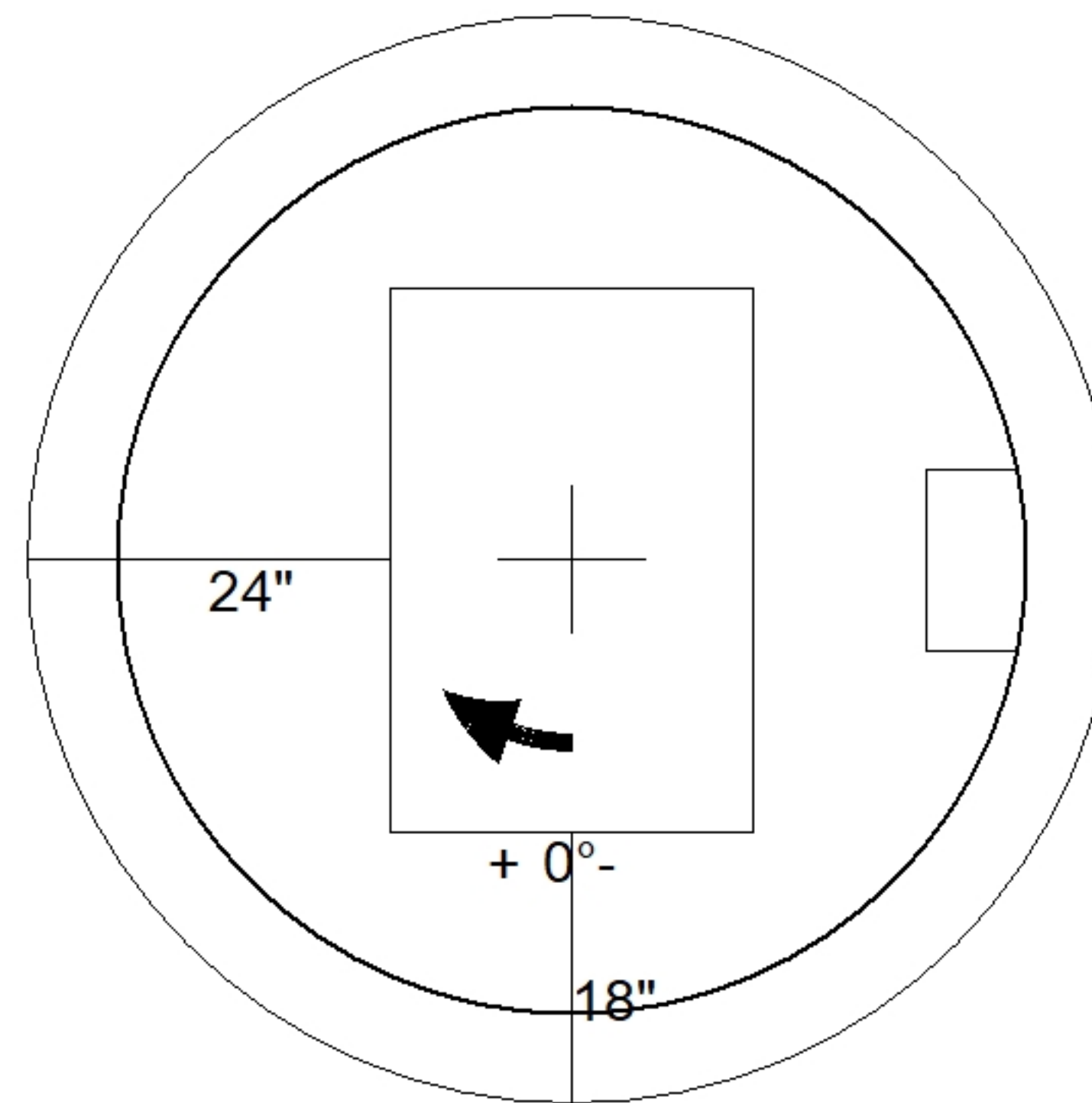

Coating (Int):  
 Coating (Ext):

Seam Up: Flat  
 Seam Dn: Groove

Wall Thickness: 6"

Height (Ext): 13"

Weight (Net): 3499 lb  
 Volume (Net): 0.89cu.yd