

Job Name: 25-3283 - Whitley County Detention Center
 Job Location: Williamsburg, KY
 Contractor: Rising Sun Development Company

Plant: 100

Tech: J. Horsley - F

12/17/2025 7:58:13 AM

PC: E. Bradley



Structure ID: DB4

P1 MH048BA42

MH BASE T/n

P5) 24" x 36" - CASTING HEIGHT - 6"	0 lb
P4) 24" x 36" - GRADE RING F/F - 3"	306 lb
P3) 48" - MH FLAT TOP w/24"x36" Hole F/G - 12"	1300 lb
P2) 48" - MH RISER T/G - 36"	2515 lb
P1) 48" - MH BASE T/n - 42"	4131 lb
2) 48" - Conseal CS-102 1.00"	0 lb
2) 24" x 36" - Conseal CS-102 1.00"	0 lb
1) Hole - 16	0 lb
1) Hole - 12	0 lb
7) MH Step ML-10-TDS-NCR - 10"	0 lb
Structure Total:	8252 lb

Structure Notes:
 1. PER ASTM C-478 SPECIFICATIONS
 2. CONCRETE: 4,000 PSI AT 28 DAYS
 3. REINFORCEMENT: PER ASTM A615
 4. STEPS AT 90 DEGREES
 5. NO INVERT CHANNEL
 6. CASTING SUPPLIED BY OTHERS (HOE 525 LV SET (FRAME / GRATE / CURB HOOD))

Rim: 1084.45' Rim to Invert: 8.41' Slack: 1.92' Sump: 0' Step Position: 90

Position	Elev	Angle	Ext. (cw)	Pipe	Pipe OD	Connector	Hole	Horz Size	Up ()	Offset
Invert 1	1076.04'	0°	0"	12" HDPE	14.5"	Hole 16	16"	16.312"	-1.25"	0"
Invert 2	1076.74'	195°	98.698"	8" HDPE	9.1"	Hole 12	12"	12.129"	7.85"	0"
Invert 3										
Invert 4										
Invert 5										
Invert 6										
Invert 7										
Invert 8										

RIGHT-SIDE UP VIEW (int. dimensions)

UPSIDE-DOWN VIEW (int. dimensions)

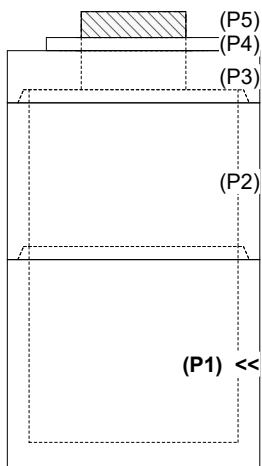
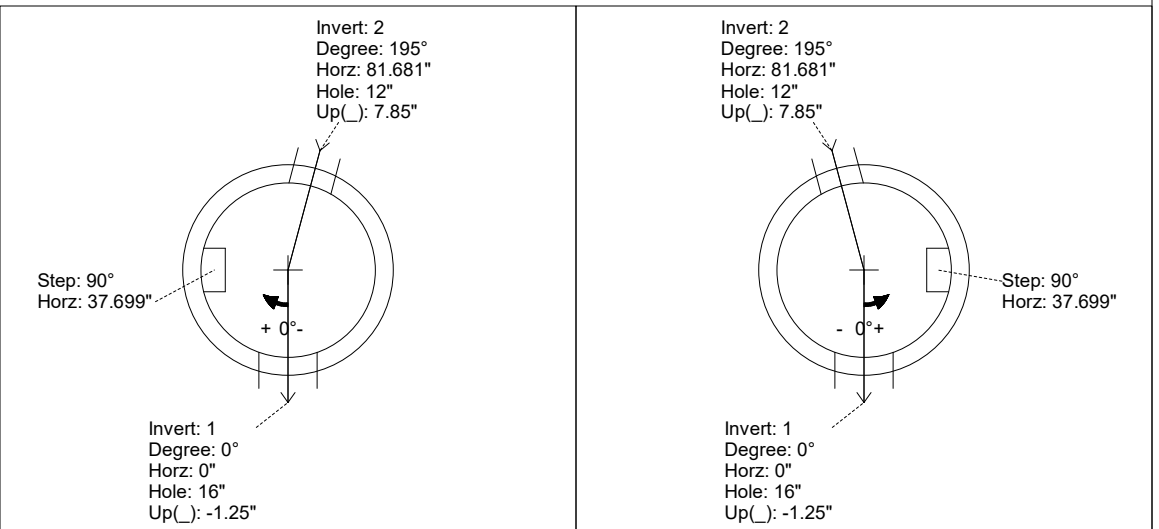

INSIDE WALL DIMENSIONS

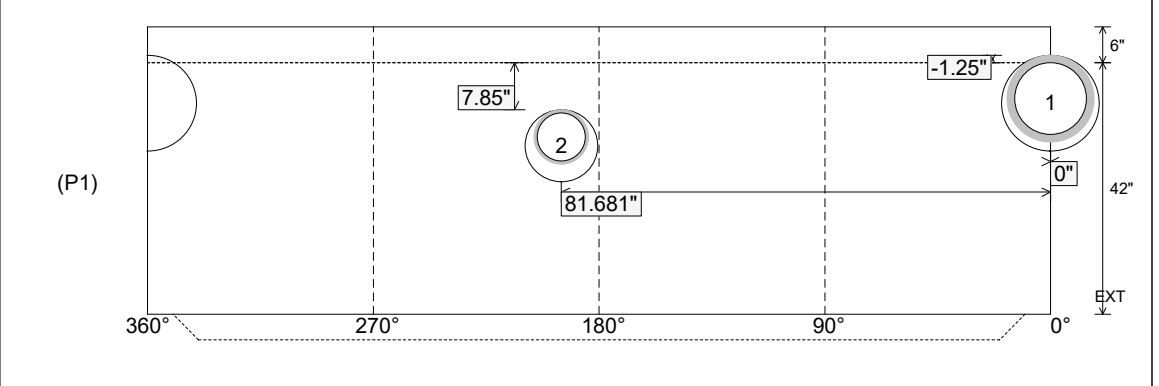

Coating (Int): Coating (Ext):	Seam Up: Tongue Seam Dn: n/a	Wall Thickness: 5" Floor Height: 6"	Height (Int): 42" Height (Ext): 48"	Weight (Net): 4131 lb Volume (Net): 1.06cu.yd
----------------------------------	---------------------------------	--	--	--