

Job Name: 25-3283 - Whitley County Detention Center
 Job Location: Williamsburg, KY
 Contractor: Rising Sun Development Company

Plant: 100
 12/17/2025 7:58:13 AM

Tech: J. Horsley - F
 PC: E. Bradley



Structure ID: DB3

P1 MH048BA60

MH BASE T/n

- P3) 24" x 36" - CASTING HEIGHT - 6"
- P2) 48" - MH FLAT TOP w/24"x36" Hole F/G - 12"
- P1) 48" - MH BASE T/n - 60"
- 1) 48" - Conseal CS-102 1.00"
- 1) 24" x 36" - Conseal CS-102 1.00"
- 1) Hole - 12
- 5) MH Step ML-10-TDS-NCR - 10"

0 lb
 1300 lb
 5474 lb
 0 lb
 0 lb
 0 lb
 0 lb

 6774 lb

Structure Total:

- Structure Notes:**
1. PER ASTM C-478 SPECIFICATIONS
 2. CONCRETE: 4,000 PSI AT 28 DAYS
 3. REINFORCEMENT: PER ASTM A615
 4. STEPS AT 180 DEGREES
 5. NO INVERT CHANNEL
 6. CASTING SUPPLIED BY OTHERS (HOE 525 LV SET (FRAME / GRATE / CURB HOOD))

Rim: 1086' Rim to Invert: 6.6' Slack: 1.2' Sump: 0' Step Position: 180°

Position	Elev	Angle	Ext. (cw)	Pipe	Pipe OD	Connector	Hole	Horz Size	Up (↓)	Offset
Invert 1	1079.4'	0°	0"	8" HDPE	9.1"	Hole 12	12"	12.129"	-0.55"	0"
Invert 2										
Invert 3										
Invert 4										
Invert 5										
Invert 6										
Invert 7										
Invert 8										

RIGHT-SIDE UP VIEW (int. dimensions)

UPSIDE-DOWN VIEW (int. dimensions)

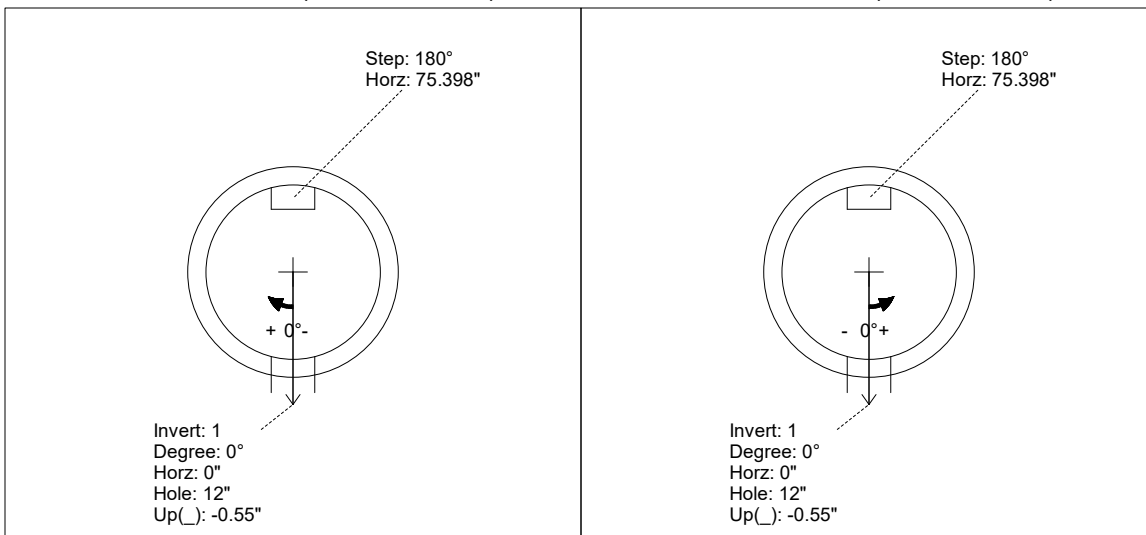

INSIDE WALL DIMENSIONS

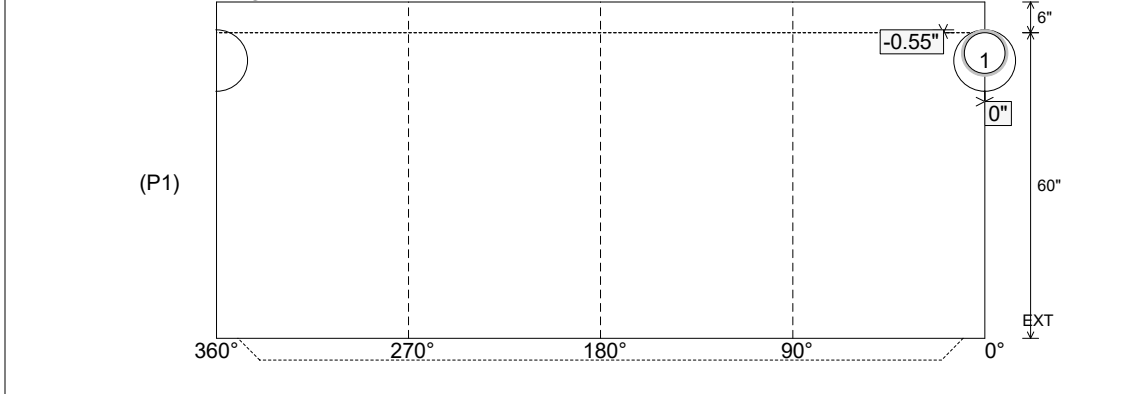

Coating (Int):
 Coating (Ext):

Seam Up: Tongue
 Seam Dn: n/a

Wall Thickness: 5"
 Floor Height: 6"

Height (Int): 60"
 Height (Ext): 66"

Weight (Net): 5474 lb
 Volume (Net): 1.4cu.yd