

Job Name: 25-3283 - Whitley County Detention Center  
 Job Location: Williamsburg, KY  
 Contractor: Rising Sun Development Company

Plant: 100

12/17/2025 7:58:12 AM

Tech: J. Horsley - F

PC: E. Bradley



**Structure ID: DB2**

**P1 MH048BAVF**

**MH BASE Custom Ht F/n**

- P3) 24" x 36" - CASTING HEIGHT - 6"
- P2) 48" - MH FLAT TOP w/24"x36" Hole F/F - 7"
- P1) 48" - MH BASE Custom Ht F/n - 64"
- 1) 48" - Conseal CS-102 1.00"
- 1) 24" x 36" - Conseal CS-102 1.00"
- 3) Hole - 16
- 5) MH Step ML-10-TDS-NCR - 10"

0 lb  
 1044 lb  
 5544 lb  
 0 lb  
 0 lb  
 0 lb  
 0 lb  
 -----  
 0 lb  
 Structure Total: 6588 lb

- Structure Notes:**
1. PER ASTM C-478 SPECIFICATIONS
  2. CONCRETE: 4,000 PSI AT 28 DAYS
  3. REINFORCEMENT: PER ASTM A615
  4. STEPS AT 281 DEGREES
  5. NO INVERT CHANNEL
  6. CASTING SUPPLIED BY OTHERS (HOE 525 LV SET (FRAME / GRATE / CURB HOOD))

Rim: 1086.19' Rim to Invert: 6.49' Slack: 0.88" Sump: 0" Step Position: 281°

Position	Elev	Angle	Ext. (cw)	Pipe	Pipe OD	Connector	Hole	Horz Size	Up ( )	Offset
Invert 1	1079.7'	0°	0"	12" HDPE	14.5"	Hole 16	16"	16.312"	-1.25"	0"
Invert 2	1081.39'	120°	60.737"	12" HDPE	14.5"	Hole 16	16"	16.312"	19.03"	0"
Invert 3	1083.25'	202°	102.241"	12" PVC SDR35	12.5"	Hole 16	16"	16.312"	42.35"	0"
Invert 4										
Invert 5										
Invert 6										
Invert 7										
Invert 8										

RIGHT-SIDE UP VIEW (int. dimensions)

UPSIDE-DOWN VIEW (int. dimenions)

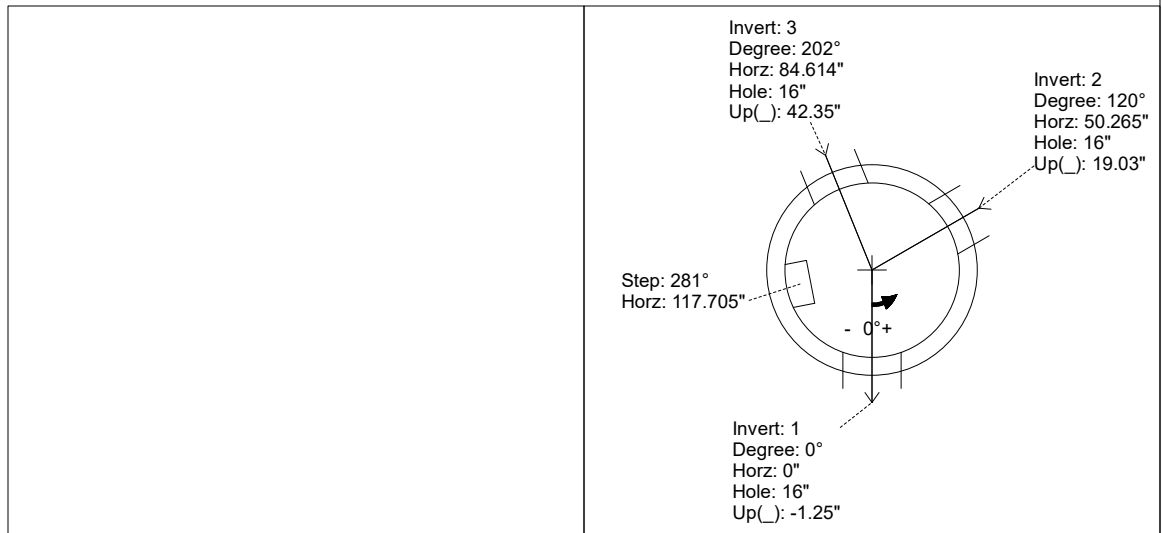
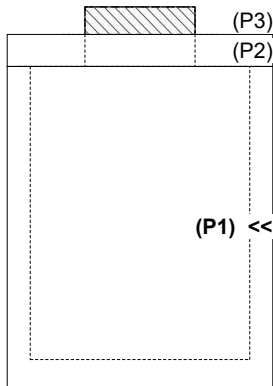

INSIDE WALL DIMENSIONS

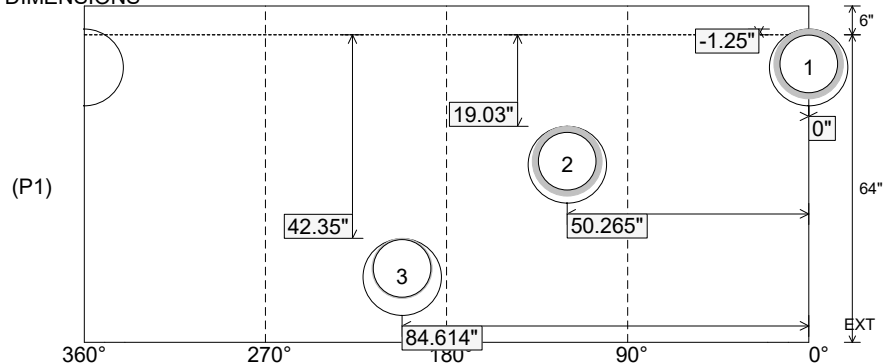

Coating (Int):  
 Coating (Ext):

Seam Up: Flat  
 Seam Dn: n/a

Wall Thickness: 5"  
 Floor Height: 6"

Height (Int): 64"  
 Height (Ext): 70"

Weight (Net): 5544 lb  
 Volume (Net): 1.42cu.yd