

| | | | |
|--|-----------------------|----------------------|--|
| Job Name: 25-3264 - Sam Ridley Parkway Roadway Improvements | Plant: 100 | Tech: J. Horsley - F |  |
| Job Location: Smyrna, TN Contractor: Capital City Construction Services LLC | 12/16/2025 8:34:53 AM | PC: A. Chambers | |

Structure ID: CB-09

P1 BX3232-08BAVF

BOX BASE 8inW, 8inF, Variable Ht F/n

P2) 32" x 32" - CASTING HEIGHT - 7"
P1) 32" x 32" - BOX BASE 8inW, 8inF, Variable Ht F/n - 44"
1) CASTING - JBS 3123-12 Mod. Single Set
1) 32" x 32" - Conseal CS-102 1.00"
2) Hole - 26

0 lb
5560 lb
250 lb
0 lb
0 lb

Structure Total: 5810 lb

Structure Notes:
1. PER TDOT STANDARD DRAWING D-CB-12LP & ASTM C-913 SPECS
2. CONCRETE: 4,000 PSI AT 28 DAYS
3. REINFORCEMENT: PER TDOT & ASTM A615 SPECS
4. NO STEPS
5. NO INVERT CHANNEL
6. CASTING BY ICAST (JBS 3123-12 MOD. SINGLE SET)

Rim: 594.75' Rim to Invert: 4.12' Slack: 0.94" Sump: 2.5" Step Position:

| Position | Elev | Angle | Ext. (cw) | Pipe | Pipe OD | Connector | Hole | Horz Size | Up () | Offset |
|----------|---------|-------|-----------|----------------|---------|-----------|------|-----------|--------|--------|
| Invert 1 | 590.63' | 0° | 24" | 18" RCP B WALL | 23" | Hole 26 | 26" | 26" | 0" | 0" |
| Invert 2 | 590.8' | 180° | 24" | 18" RCP B WALL | 23" | Hole 26 | 26" | 26" | 2.04" | 0" |
| Invert 3 | | | | | | | | | | |
| Invert 4 | | | | | | | | | | |
| Invert 5 | | | | | | | | | | |
| Invert 6 | | | | | | | | | | |
| Invert 7 | | | | | | | | | | |
| Invert 8 | | | | | | | | | | |

RIGHT-SIDE UP VIEW (int. dimensions)

UPSIDE-DOWN VIEW (int. dimensions)

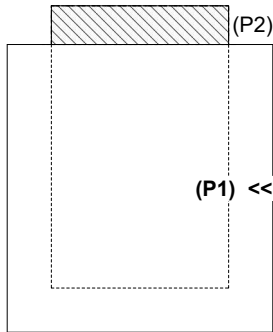

INSIDE WALL DIMENSIONS

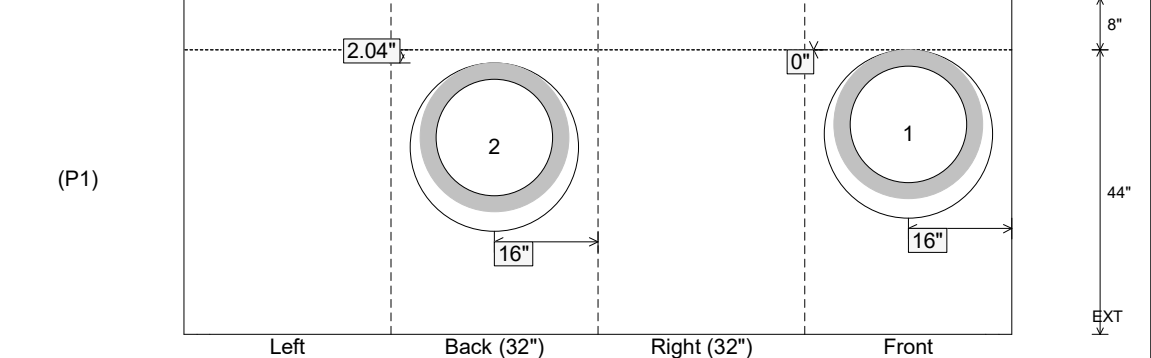

| | | | | |
|----------------------------------|-------------------------------|--|--|--|
| Coating (Int): Coating (Ext): | Seam Up: Flat Seam Dn: n/a | Wall Thickness: 8" Floor Height: 8" | Height (Int): 44" Height (Ext): 52" | Weight (Net): 5560 lb Volume (Net): 1.42cu.yd |
|----------------------------------|-------------------------------|--|--|--|