

Job Name: 25-3264 - Sam Ridley Parkway Roadway Improvements	Plant: 100	Tech: J. Horsley - F	
Job Location: Smyrna, TN Contractor: Capital City Construction Services LLC	12/16/2025 8:34:52 AM	PC: A. Chambers	

Structure ID: CB-08

P1 BX36960606VF

BOX BASE 6inW, 6inF, Variable Ht F/n

P3) 28" x 34" - CASTING HEIGHT - 7"	0 lb
P2) 36" x 96" - BX FLAT TOP 6"W - TDOT NO 14 (2-28"x34" HOLES) F/F - 10"	2752 lb
P1) 36" x 96" - BOX BASE 6inW, 6inF, Variable Ht F/n - 41"	8020 lb
1) SECONDARY POUR	0 lb
1) CASTING - JBS 3123-14 Mod. Double Set	250 lb
1) 28" x 34" - Conseal CS-102 1.00"	0 lb
2) Hole - 26	0 lb
Structure Total:	11023 lb

- Structure Notes:**
- PER TDOT STANDARD DRAWING D-CB-14P & ASTM C-913 SPECS
 - CONCRETE: 4,000 PSI AT 28 DAYS
 - REINFORCEMENT: PER TDOT & ASTM A615 SPECS
 - NO STEPS
 - NO INVERT CHANNEL
 - CASTING BY ICAST (JBS 3123-14 MOD. DOUBLE SET)
 - WET STICK 18" X 20" #4 L-BARS SPACED @ 12" C.C. E.W. (GRADE 60) OUT OF FLOOR FOR WALL POUR TIE-IN (SEE L-BAR DETAIL)

FIRST POUR (FLOOR): 2,610 LBS
SECOND POUR (WALLS): 5,410 LBS

Rim: 594.13' Rim to Invert: 4.67' Slack: 0.54" Sump: 2.5" Step Position:

Position	Elev	Angle	Ext. (cw)	Pipe	Pipe OD	Connector	Hole	Horz Size	Up ()	Offset
Invert 1	589.46'	0°	24"	18" RCP B WALL	23"	Hole 26	26"	26"	0"	0"
Invert 2	589.79'	180°	24"	18" RCP B WALL	23"	Hole 26	26"	26"	3.96"	0"
Invert 3										
Invert 4										
Invert 5										
Invert 6										
Invert 7										
Invert 8										

RIGHT-SIDE UP VIEW (int. dimensions)

UPSIDE-DOWN VIEW (int. dimensions)

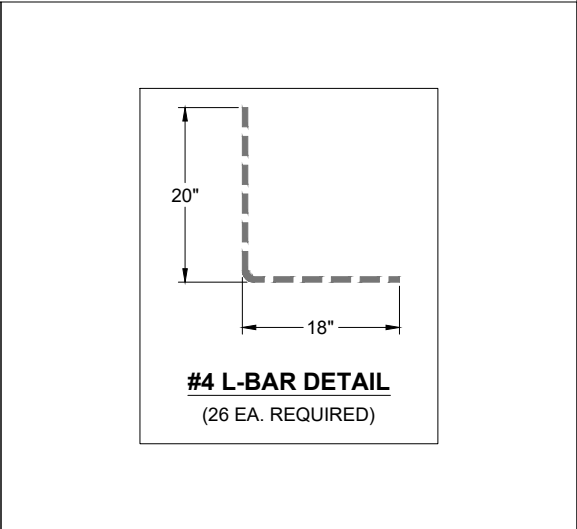
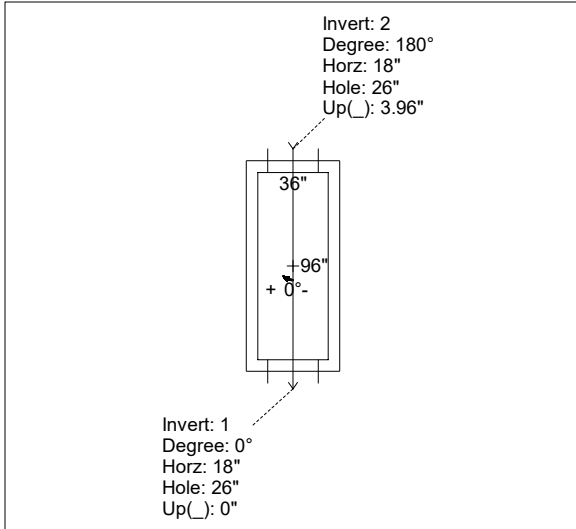
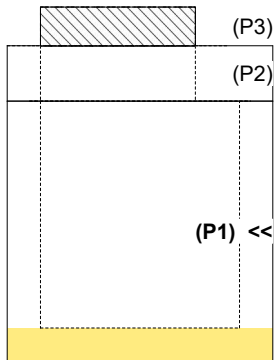

INSIDE WALL DIMENSIONS

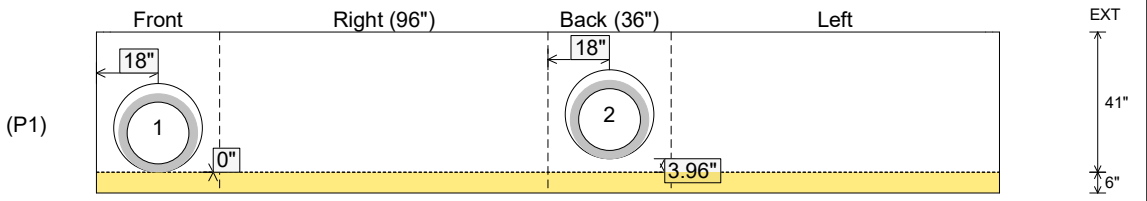

Coating (Int): Coating (Ext):	Seam Up: Flat Seam Dn: n/a	Wall Thickness: 6" Floor Height: 6"	Height (Int): 41" Height (Ext): 47"	Weight (Net): 8020 lb Volume (Net): 2.05cu.yd
----------------------------------	-------------------------------	--	--	--

Job Name: 25-3264 - Sam Ridley Parkway Roadway Improvements	Plant: 100	Tech: J. Horsley - F	
Job Location: Smyrna, TN Contractor: Capital City Construction Services LLC	12/16/2025 8:34:52 AM	PC: A. Chambers	

Structure ID: CB-08

P1 BX36960606VF

BOX BASE 6inW, 6inF, Variable Ht F/n

P3) 28" x 34" - CASTING HEIGHT - 7"	0 lb
P2) 36" x 96" - BX FLAT TOP 6"W - TDOT NO 14 (2-28"x34" HOLES) F/F - 10"	2752 lb
P1) 36" x 96" - BOX BASE 6inW, 6inF, Variable Ht F/n - 41"	8020 lb
1) SECONDARY POUR	0 lb
1) CASTING - JBS 3123-14 Mod. Double Set	250 lb
1) 28" x 34" - Conseal CS-102 1.00"	0 lb
2) Hole - 26"	0 lb
Structure Total:	11023 lb

- Structure Notes:**
- PER TDOT STANDARD DRAWING D-CB-14P & ASTM C-913 SPECS
 - CONCRETE: 4,000 PSI AT 28 DAYS
 - REINFORCEMENT: PER TDOT & ASTM A615 SPECS
 - NO STEPS
 - NO INVERT CHANNEL
 - CASTING BY ICAST (JBS 3123-14 MOD. DOUBLE SET)
 - LIFTERS: 4 EA. 5CA18 CONAC A-ANCHORS FOR PLANT & FIELD HANDLING - INSTALLED IN 90° & 180° WALLS, MIN. 16" FROM TOP OF WALLS

FIRST POUR (FLOOR): 2,610 LBS
SECOND POUR (WALLS): 5,410 LBS

Rim: 594.13' Rim to Invert: 4.67' Slack: 0.54" Sump: 2.5" Step Position:

Position	Elev	Angle	Ext. (cw)	Pipe	Pipe OD	Connector	Hole	Horz Size	Up ()	Offset
Invert 1	589.46'	0°	24"	18" RCP B WALL	23"	Hole 26	26"	26"	0"	0"
Invert 2	589.79'	180°	24"	18" RCP B WALL	23"	Hole 26	26"	26"	3.96"	0"
Invert 3										
Invert 4										
Invert 5										
Invert 6										
Invert 7										
Invert 8										

RIGHT-SIDE UP VIEW (int. dimensions) UPSIDE-DOWN VIEW (int. dimenions)

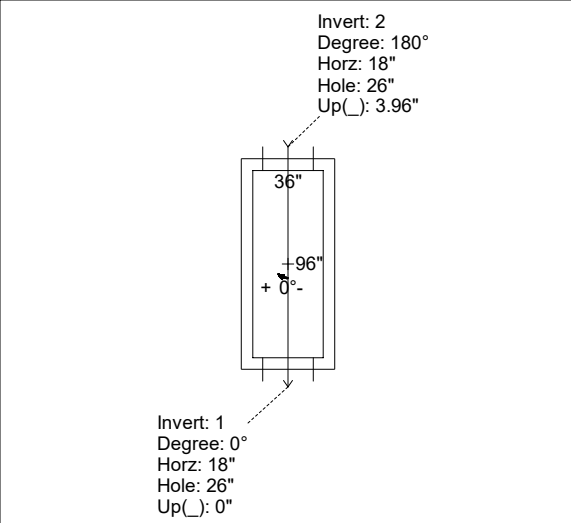
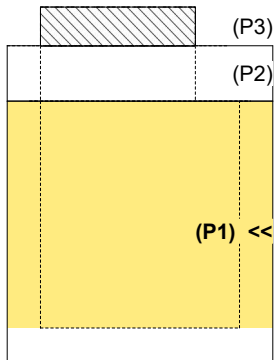

INSIDE WALL DIMENSIONS

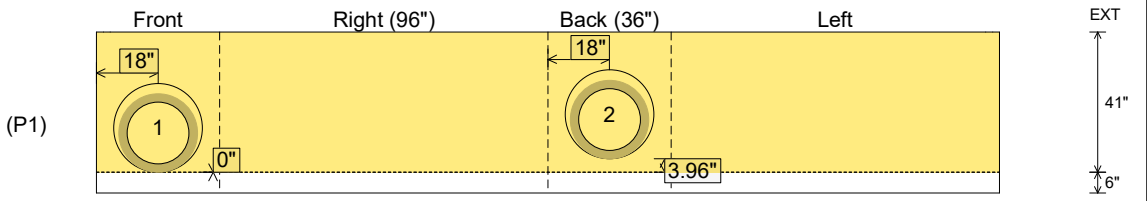

Coating (Int): Coating (Ext):	Seam Up: Flat Seam Dn: n/a	Wall Thickness: 6" Floor Height: 6"	Height (Int): 41" Height (Ext): 47"	Weight (Net): 8020 lb Volume (Net): 2.05cu.yd
----------------------------------	-------------------------------	--	--	--