

Job Name: 25-3198 - Garner Farm Ph 2
Job Location: Somerset, Ky
Contractor: Weddle Enterprises, Inc

PC: C. Goff
 TECH: C. Russ
 Plant: Beaver Dam



Structure ID: MHD6

Spec: Sanitary
 Type: SAN.MH
 Size: 48"

Rim: 1045.85'
 Invert: 1040.65'
 Rim to Invert: 5.2'

Sump: 2"
 Floor (Top): 1040.483'
 Floor Height: 6"

Floor (Bot): 1039.983'
 Overall Height: 5.833'
 Slack: 0.4"

Structure Notes:

- PER ASTM C-478 SPECIFICATIONS
- CONCRETE: 4,000 PSI AT 28 DAYS
- REINFORCEMENT: PER ASTM A615
- INVERT CHANNEL REQUIRED
- STEPS AT 0 DEGREES
- HOE MC-350 FRAME & COVER "SANITARY" SUPPLIED BY OTHERS
- EACH BOOT IS TO RECEIVE DOUBLE PIPE BANDS (SUPPLIED BY ICAST)

STRUCTURE SUMMARY:

- P4) 24" - CASTING HEIGHT - 7" 0 lb
 - P3) 24" - GRADE RING F/F - 3" 202 lb
 - P2) 48" - ECC CONE w/ 24" HOLE F/G - 24" 1550 lb
 - P1) 48" - MH BASE T/n - 30" 3330 lb
 - 1) 48" - MH INVERT CHANNEL - FULL HEIGHT 1440 lb
 - 1) JOINT WRAP - 0.065"x6"x50' CONSEAL CS212 0 lb
 - 1) JOINT WRAP PRIMER - CONSEAL CS-75 (1 gal.) 0 lb
 - 1) 48" - Conseal CS-102 1.00" (Double) 0 lb
 - 2) PSX - 12-08 NYLO 16 lb
 - 4) MH Step ML-10-TDS-NCR - 10" 0 lb
- Structure Total: 6539 lb

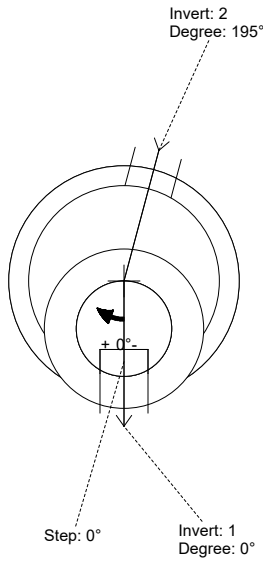

Position	Elev	Angle	Pipe	Pipe OD	Hole	Connector	Up (L)	Ref
Rim	1045.85'							
Reducer								
Invert 1	1040.65'	0°	8" PVC SDR35	8.5"	12"	PSX 12-08 NYLO	0"	P1
Invert 2	1040.75'	195°	8" PVC SDR35	8.5"	12"	PSX 12-08 NYLO	1.2"	P1
Invert 3								
Invert 4								
Invert 5								
Invert 6								
Invert 7								
Invert 8								

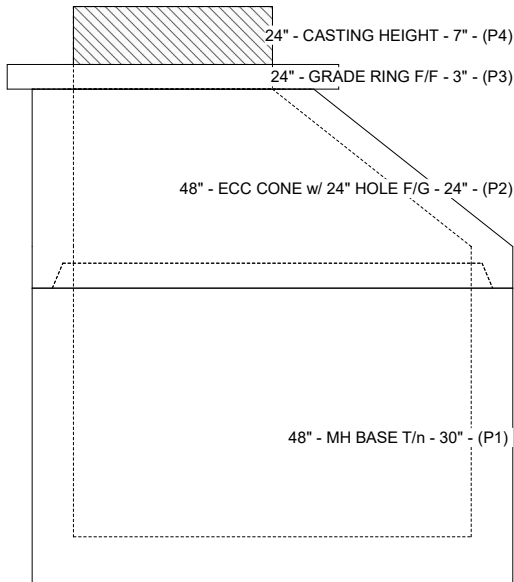

Cast (Int. Dim.) - Interior Dimensions

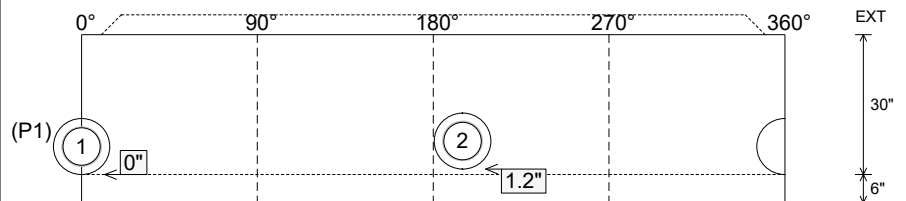

Submittal Drawing
 1/27/2026 2:03:26 PM

SUBMITTAL
 APPROVED BY: