

Job Name: 25-3198 - Garner Farm Ph 2
 Job Location: Somerset, Ky
 Contractor: Weddle Enterprises, Inc

Plant: Beaver Dam
 1/27/2026 2:11:27 PM

Tech: C. Russ
 PC: C. Goff



Structure ID: MHD4

P2 MH048CN36

ECC CONE w/ 24" HOLE F/G

- P3) 24" - CASTING HEIGHT - 7"
- P2) 48" - ECC CONE w/ 24" HOLE F/G - 36"
- P1) 48" - MH BASE T/n - 30"
- 1) 48" - MH INVERT CHANNEL - FULL HEIGHT
- 1) JOINT WRAP - 0.065"x6"x50" CONSEAL CS212
- 1) JOINT WRAP PRIMER - CONSEAL CS-75 (1 gal.)
- 1) 48" - Conseal CS-102 1.00" (Double)
- 2) PSX - 16Y NYLO
- 4) MH Step ML-10-TDS-NCR - 10"

0 lb
 3000 lb
 3255 lb
 1440 lb
 0 lb
 0 lb
 0 lb
 0 lb
 16 lb
 0 lb

 Structure Total: 7711 lb

- Structure Notes:
1. PER ASTM C-478 SPECIFICATIONS
 2. CONCRETE: 4,000 PSI AT 28 DAYS
 3. REINFORCEMENT: PER ASTM A615
 4. STEPS REQUIRED
 5. HOE MC-350 FRAME & COVER "SANITARY" SUPPLIED BY OTHERS

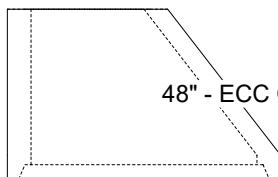
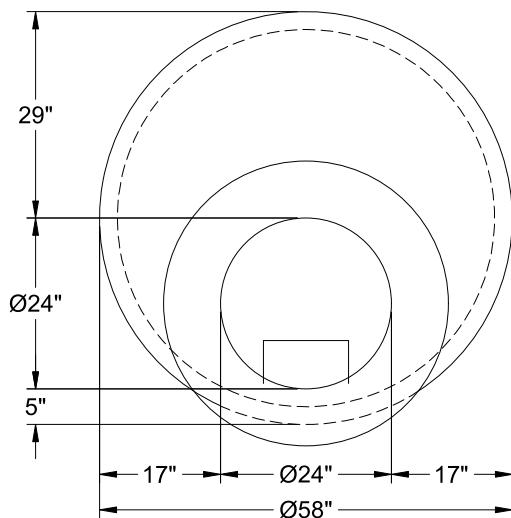

48" - ECC CONE w/ 24" HOLE F/G - 36" - (P2)

Coating (Int):
 Coating (Ext):

Seam Up: Flat
 Seam Dn: Groove

Wall Thickness: 5"

Height (Ext): 36"

Weight (Net): 3000 lb
 Volume (Net): 0.5cu.yd