

Job Name: 25-3198 - Garner Farm Ph 2
Job Location: Somerset, Ky
Contractor: Weddle Enterprises, Inc

PC: C. Goff
 TECH: C. Russ
 Plant: Beaver Dam



Structure ID: CBI 22

Spec: Storm
 Type: STM.MH (Recessed pipe)
 Size: 48"

Rim: 1031.1'
 Invert: 1026.6'
 Rim to Invert: 4.5'

Sump: 0"
 Floor (Top): 1026.6'
 Floor Height: 6"

Floor (Bot): 1026.1'
 Overall Height: 4.958'
 Slack: 0.5"

Structure Notes:

1. PER ASTM C-478 SPECIFICATIONS
2. CONCRETE: 4,000 PSI AT 28 DAYS
3. REINFORCEMENT:
 - FLAT LID: #4 BAR @ 10" C.C. E.W. (GRADE 60)
 - BASE: PER ASTM A615
4. NO STORM INVERT
5. STEPS AT 90 DEGREES
6. HOE 580-A FRAME & GRATES SUPPLIED BY OTHERS

STRUCTURE SUMMARY:

- P3) 18" x 36" - CASTING HEIGHT - 5.5" 0 lb
 - P2) 48" - MH FLAT TOP w/18"x36" Hole F/G - 12" 2008 lb
 - P1) 48" - MH BASE T/n - 36" 3513 lb
 - 1) 48" - Conseal CS-102 1.00" 0 lb
 - 1) 18" x 36" - Conseal CS-102 1.00" 0 lb
 - 1) Hole - 24 0 lb
 - 1) Hole - 20 0 lb
 - 3) MH Step ML-10-TDS-NCR - 10" 0 lb
- Structure Total: 5521 lb

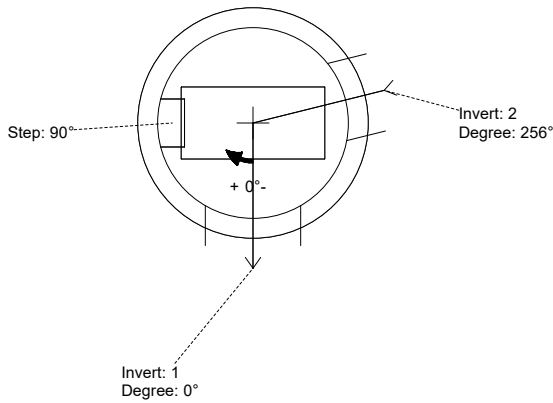

Position	Elev	Angle	Pipe	Pipe OD	Hole	Connector	Up (L)	Ref
Rim	1031.1'							
Reducer								
Invert 1	1026.6'	0°	18" HDPE	21.2"	24"	Hole 24	-1.6"	P1
Invert 2	1026.6'	256°	15" HDPE	17.6"	20"	Hole 20	-1.3"	P1
Invert 3								
Invert 4								
Invert 5								
Invert 6								
Invert 7								
Invert 8								

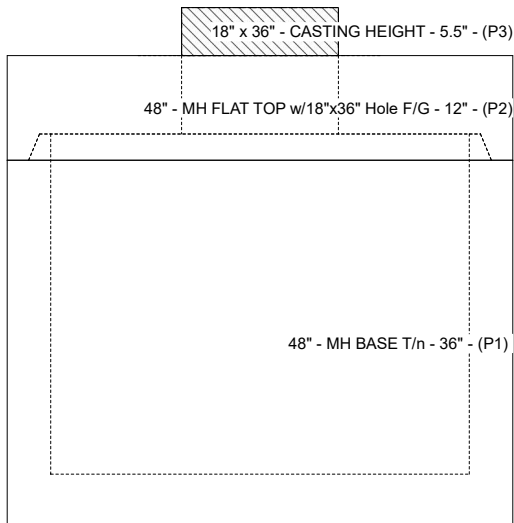

Cast (Int. Dim.) - Interior Dimensions

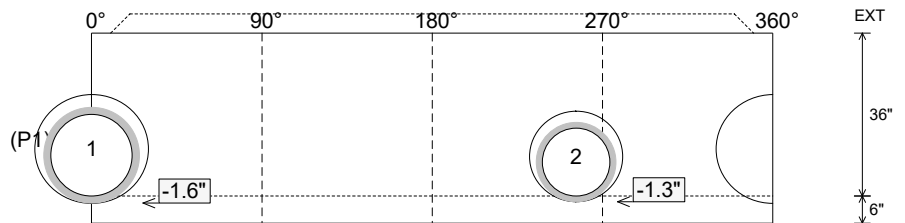

Submittal Drawing
 1/27/2026 2:03:17 PM

SUBMITTAL
 APPROVED BY: