

Job Name: 25-3198 - Garner Farm Ph 2
 Job Location: Somerset, Ky
 Contractor: Weddle Enterprises, Inc

Plant: Beaver Dam

Tech: C. Russ

1/27/2026 2:10:12 PM

PC: C. Goff



Structure ID: CBI 15

P1 MH072BA78

MH BASE T/n

- P3) 18" x 36" - CASTING HEIGHT - 5.5"
- P2) 72" - MH FLAT TOP w/18"x36" Hole F/G - 15"
- P1) 72" - MH BASE T/n - 78"
- 1) 72" - Conseal CS-102 1.00"
- 1) 18" x 36" - Conseal CS-102 1.00"
- 1) Hole - 56
- 1) Hole - 20
- 1) Hole - 50
- 6) MH Step ML-10-TDS-NCR - 10"

0 lb
 4875 lb
 12214 lb
 0 lb
 0 lb
 0 lb
 0 lb
 0 lb
 0 lb
 0 lb
 Structure Total: 17089 lb

- Structure Notes:**
1. PER ASTM C-478 SPECIFICATIONS
 2. CONCRETE: 4,000 PSI AT 28 DAYS
 3. REINFORCEMENT: PER ASTM A615
 4. NO STORM INVERT
 5. STEPS AT 270 DEGREES
 6. HOE 580-A FRAME & GRATES SUPPLIED BY OTHERS

Rim: 1007.07' Rim to Invert: 8' Slack: 0.65" Sump: 3.15" Step Position: 270°

Position	Elev	Angle	Ext. (cw)	Pipe	Pipe OD	Connector	Hole	Horz Size	Up ()	Offset
Invert 1	999.07'	0°	0"	48" HDPE	53.5"	Hole 56	56"	64.161"	0.2"	0"
Invert 2	999.07'	79°	59.289"	15" HDPE	17.6"	Hole 20	20"	20.267"	1.85"	0"
Invert 3	999.07'	170°	127.584"	42" HDPE	47.7"	Hole 50	50"	55.271"	0"	0"
Invert 4										
Invert 5										
Invert 6										
Invert 7										
Invert 8										

RIGHT-SIDE UP VIEW (int. dimensions)

UPSIDE-DOWN VIEW (int. dimensions)

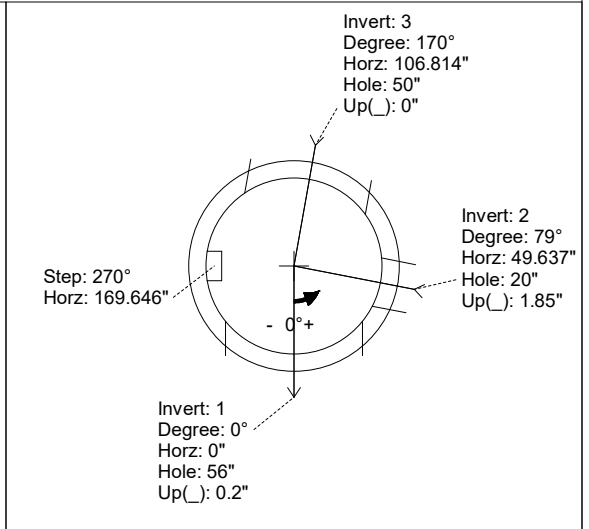
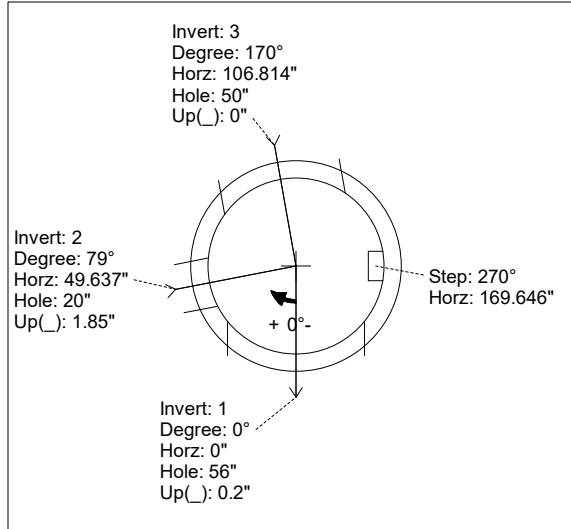
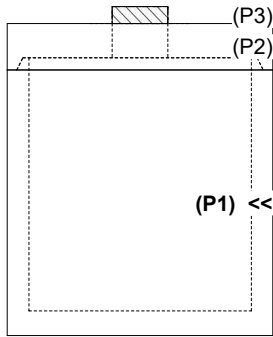

INSIDE WALL DIMENSIONS

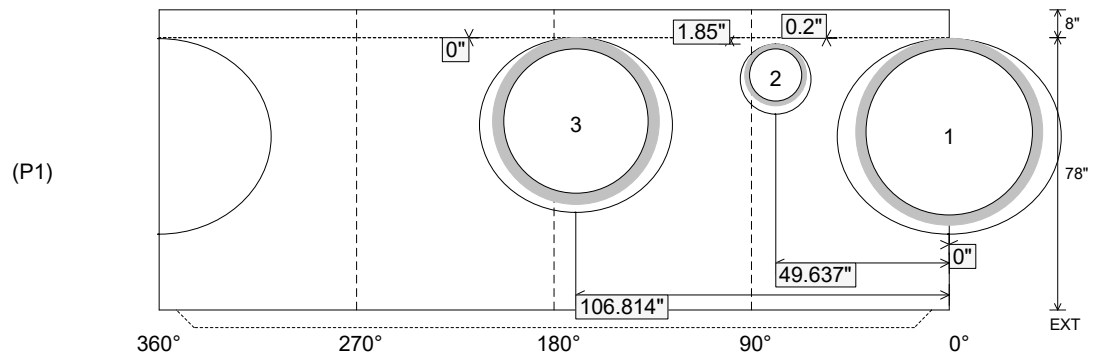

Coating (Int):
 Coating (Ext):

Seam Up: Tongue
 Seam Dn: n/a

Wall Thickness: 7"
 Floor Height: 8"

Height (Int): 78"
 Height (Ext): 86"

Weight (Net): 12214 lb
 Volume (Net): 3.12cu.yd