

Job Name: 25-3194B KYTC Todd Co Call 101 (251113)
 Job Location: Guthrie, KY
 Contractor: Scott & Ritter, Inc.

Plant: 100
 11/17/2025 1:49:29 PM

Tech: J. Horsley - A
 PC: Celina Goff



Structure ID: 1+02 (48+35 LT)

P2 MH048RS24

MH RISER T/G

- P4) 24" - CASTING HEIGHT - 7"
- P3) 48" - ECC CONE w/ 24" HOLE F/G - 42"
- P2) 48" - MH RISER T/G - 24"
- P1) 48" - MH BASE T/n - 24"
- 1) JOINT WRAP - 0.065"x6"x50' CONSEAL CS212
- 1) JOINT WRAP PRIMER - CONSEAL CS-75 (1 gal.)
- 1) 48" - MH INVERT CHANNEL - FULL HEIGHT
- 2) 48" - Conseal CS-102 1.00" (Double)
- 1) PSX - 16Y NYLO
- 7) MH Step ML-10-TDS-NCR - 10"

- Structure Notes:**
 STATION: 1+02 (US 79 NEAR 48+50)
1. HOE MC-315 F/C "Sanitary" PROVIDED BY ICAST.
 2. PER ASTM C478 SPECIFICATIONS.
 3. CONCRETE = 4,000 PSI AT 28 DAYS.
 4. REINFORCING PER ASTM A615 (GRADE 60).
 - CONE (As .12)
 - RISER/WALLS (As .12)
 - FLOOR (As .31) #5 BARS AT 12" C.C.E.W.

Structure Total: 9246 lb

Rim: 552.22' Rim to Invert: 8' Slack: 2" Sump: 3" Step Position: 0°

| Position | Elev | Angle | Ext. (cw) | Pipe | Pipe OD | Connector | Hole | Horz Size | Up (L) | Offset |
|----------|------|-------|-----------|------|---------|-----------|------|-----------|--------|--------|
| Invert 1 | | | | | | | | | | |
| Invert 2 | | | | | | | | | | |
| Invert 3 | | | | | | | | | | |
| Invert 4 | | | | | | | | | | |
| Invert 5 | | | | | | | | | | |
| Invert 6 | | | | | | | | | | |
| Invert 7 | | | | | | | | | | |
| Invert 8 | | | | | | | | | | |

RIGHT-SIDE UP VIEW (int. dimensions)

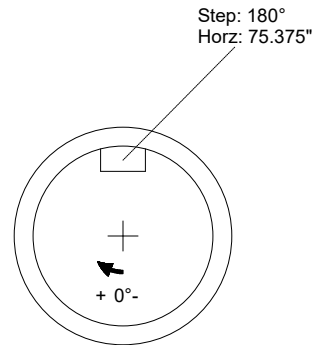
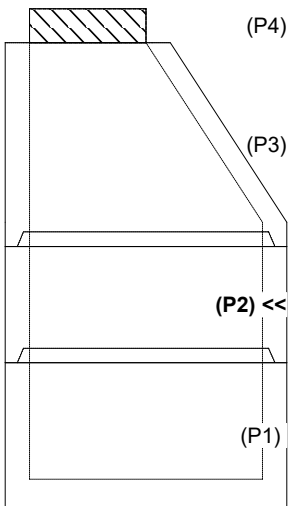

INSIDE WALL DIMENSIONS

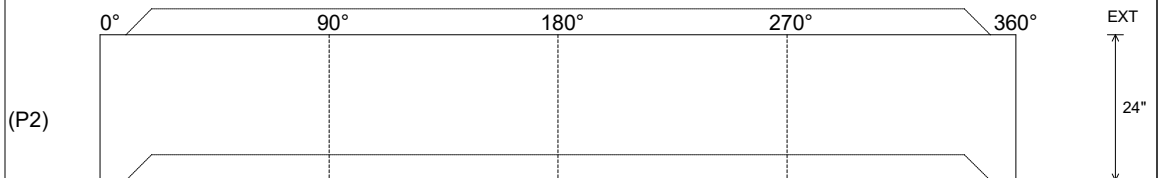

| | | | | |
|----------------|-----------------|--------------------|-------------------|-------------------------|
| Coating (Int): | Seam Up: Tongue | Wall Thickness: 5" | Height (Int): 24" | Weight (Net): 1677 lb |
| Coating (Ext): | Seam Dn: Groove | Floor Height: 0" | Height (Ext): 24" | Volume (Net): 0.43cu.yd |