

Job Name: 25-3194B KYTC Todd Co Call 101 (251113)
 Job Location: Guthrie, KY
 Contractor: Scott & Ritter, Inc.

Plant: 100
 11/17/2025 1:48:46 PM

Tech: J. Horsley - A
 PC: Celina Goff



Structure ID: 0+40 (62+75 LT)

P1 MH048BA30

MH BASE T/n

- P4) 24" - CASTING HEIGHT - 7"
- P3) 48" - ECC CONE w/ 24" HOLE F/G - 36"
- P2) 48" - MH RISER T/G - 36"
- P1) 48" - MH BASE T/n - 30"
- 1) JOINT WRAP - 0.065"x6"x50' CONSEAL CS212
- 1) JOINT WRAP PRIMER - CONSEAL CS-75 (1 gal.)
- 1) 48" - MH INVERT CHANNEL - FULL HEIGHT
- 2) 48" - Conseal CS-102 1.00" (Double)
- 2) PSX - 12-08 NYLO
- 8) MH Step ML-10-TDS-NCR - 10"

- Structure Notes:**
 STATION: 0+40 (US 79 NEAR 62+50)
1. HOE MC-315 F/C "Sanitary" PROVIDED BY ICAST.
 2. PER ASTM C478 SPECIFICATIONS.
 3. CONCRETE = 4,000 PSI AT 28 DAYS.
 4. REINFORCING PER ASTM A615 (GRADE 60).
 - CONE (As .12)
 - RISER/WALLS (As .12)
 - FLOOR (As .31) #5 BARS AT 12" C.C.E.W.

Structure Total: 10301 lb

Rim: 550.13' Rim to Invert: 9' Slack: 1" Sump: 2" Step Position: 0°

Position	Elev	Angle	Ext. (cw)	Pipe	Pipe OD	Connector	Hole	Horz Size	Up ()	Offset
Invert 1	541.13'	0°	0"	8" PVC SDR35	8.5"	PSX 12-08 NYLO	12"	12.129"	0"	0"
Invert 2	541.23'	207°	104.75"	8" PVC SDR35	8.5"	PSX 12-08 NYLO	12"	12.129"	1.25"	0"
Invert 3										
Invert 4										
Invert 5										
Invert 6										
Invert 7										
Invert 8										

RIGHT-SIDE UP VIEW (int. dimensions)

UPSIDE-DOWN VIEW (int. dimensions)

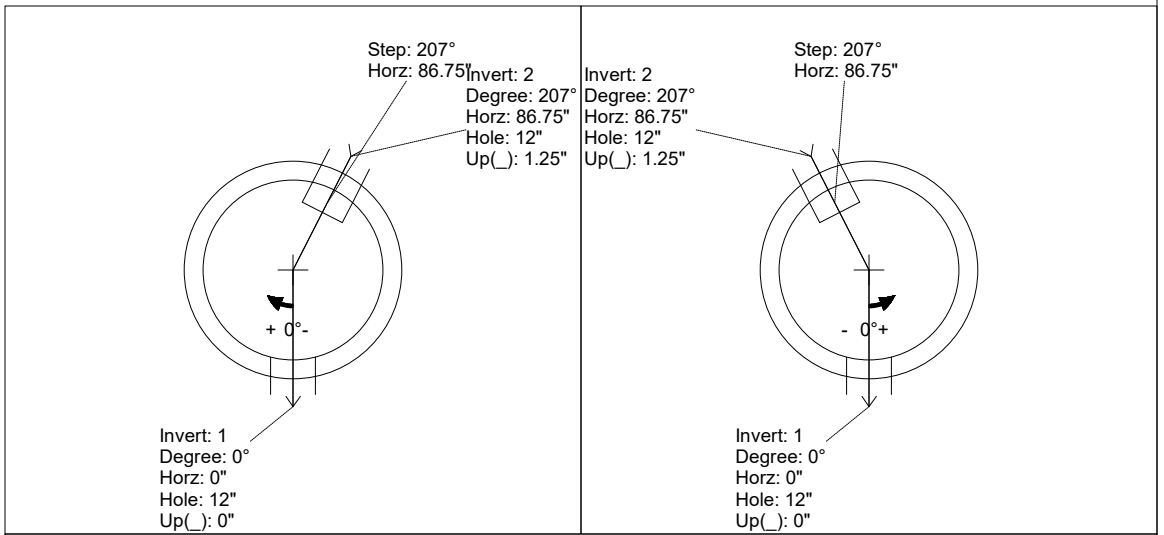
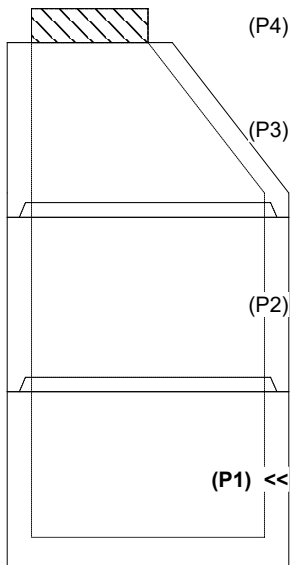

INSIDE WALL DIMENSIONS

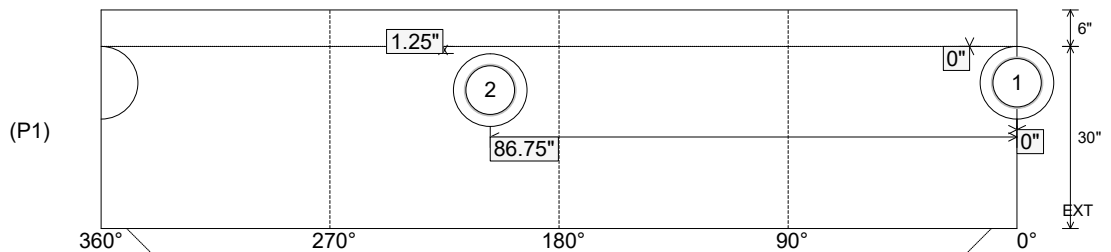

Coating (Int):
 Coating (Ext):

Seam Up: Tongue
 Seam Dn: n/a

Wall Thickness: 5"
 Floor Height: 6"

Height (Int): 30"
 Height (Ext): 36"

Weight (Net): 3330 lb
 Volume (Net): 0.85cu.yd

Job Name: 25-3194B KYTC Todd Co Call 101 (251113)
 Job Location: Guthrie, KY
 Contractor: Scott & Ritter, Inc.

Plant: 100

11/17/2025 1:48:46 PM

Tech: J. Horsley - A

PC: Celina Goff



Structure ID: 0+40 (62+75 LT)

P1 MH048BA30

MH BASE T/n

- P4) 24" - CASTING HEIGHT - 7"
- P3) 48" - ECC CONE w/ 24" HOLE F/G - 36"
- P2) 48" - MH RISER T/G - 36"
- P1) 48" - MH BASE T/n - 30"

- 1) JOINT WRAP - 0.065"x6"x50' CONSEAL CS212
- 1) JOINT WRAP PRIMER - CONSEAL CS-75 (1 gal.)
- 1) 48" - MH INVERT CHANNEL - FULL HEIGHT
- 2) 48" - Conseal CS-102 1.00" (Double)
- 2) PSX - 12-08 NYLO
- 8) MH Step ML-10-TDS-NCR - 10"

- Structure Notes:
- STATION: 0+40 (US 79 NEAR 62+50)
 - 1. HOE MC-315 F/C "Sanitary" PROVIDED BY ICAST.
 - 2. PER ASTM C478 SPECIFICATIONS.
 - 3. CONCRETE = 4,000 PSI AT 28 DAYS.
 - 4. REINFORCING PER ASTM A615 (GRADE 60).
 - CONE (As .12)
 - RISER/WALLS (As .12)
 - FLOOR (As .31) #5 BARS AT 12" C.C.E.W.

Structure Total: 10301 lb

**INVERT CHANNEL DRAWING
 FULL HEIGHT INVERT**

Rim: 550.13' Rim to Invert: 9' Slack: 1" Sump: 2" Step Position: 0°

Position	Elev	Angle	Ext. (cw)	Pipe	Pipe OD	Connector	Hole	Horz Size	Up ()	Offset
Invert 1	541.13'	0°	0"	8" PVC SDR35	8.5"	PSX 12-08 NYLO	12"	12.129"	0"	0"
Invert 2	541.23'	207°	104.75"	8" PVC SDR35	8.5"	PSX 12-08 NYLO	12"	12.129"	1.25"	0"
Invert 3										
Invert 4										
Invert 5										
Invert 6										
Invert 7										
Invert 8										

RIGHT-SIDE UP VIEW (int. dimensions)

UPSIDE-DOWN VIEW (int. dimensions)

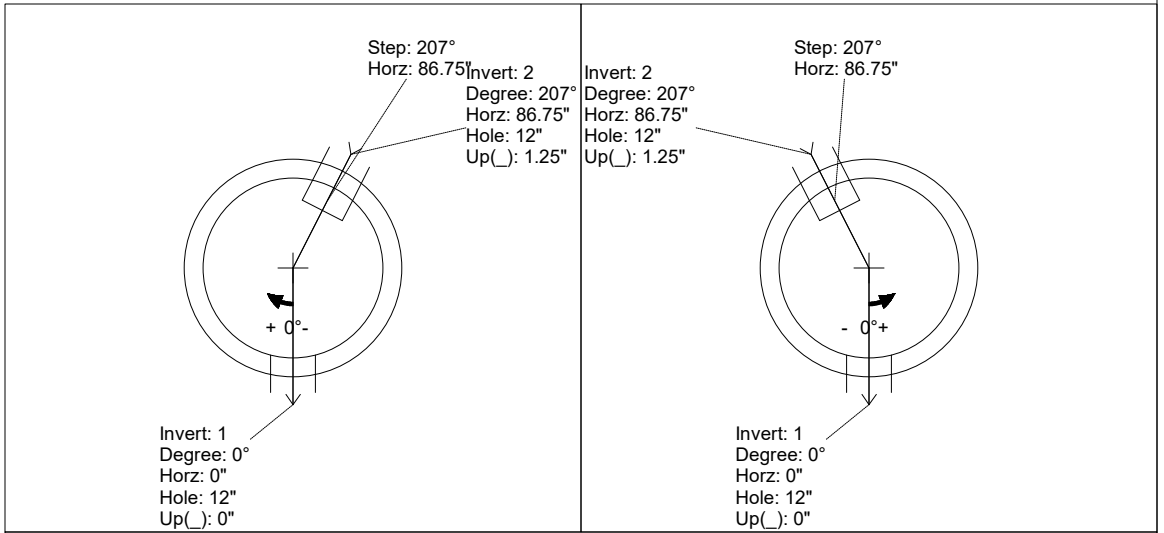
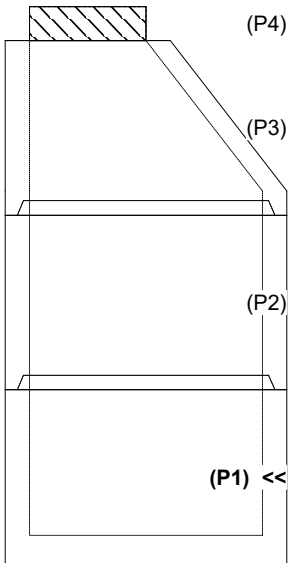

INSIDE WALL DIMENSIONS

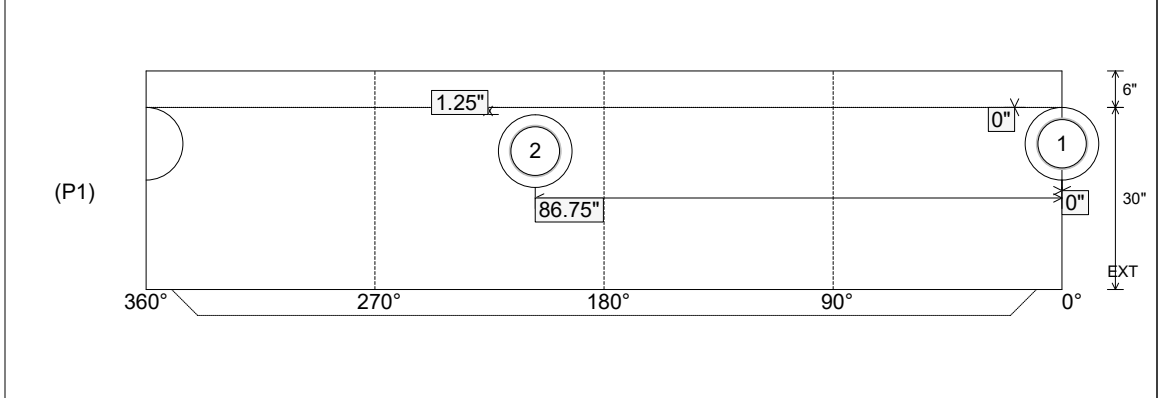

Coating (Int):
 Coating (Ext):

Seam Up: Tongue
 Seam Dn: n/a

Wall Thickness: 5"
 Floor Height: 6"

Height (Int): 30"
 Height (Ext): 36"

Weight (Net): 3330 lb
 Volume (Net): 0.85cu.yd