

Job Name: 25-3194B KYTC Todd Co Call 101 (251113)
 Job Location: Guthrie, KY
 Contractor: Scott & Ritter, Inc.

Plant: 100

Tech: J. Horsley - A

11/17/2025 1:48:45 PM

PC: Celina Goff



Structure ID: 0+40 (29+25 LT)

P1 MH048BA42

MH BASE T/n

- P3) 24" - CASTING HEIGHT - 7"
- P2) 48" - ECC CONE w/ 24" HOLE F/G - 42"
- P1) 48" - MH BASE T/n - 42"
- 1) JOINT WRAP - 0.065"x6"x50' CONSEAL CS212
- 1) JOINT WRAP PRIMER - CONSEAL CS-75 (1 gal.)
- 1) 48" - MH INVERT CHANNEL - FULL HEIGHT
- 1) 48" - Conseal CS-102 1.00" (Double)
- 4) PSX - 12-08 NYLO
- 7) MH Step ML-10-TDS-NCR - 10"

0 lb
 3200 lb
 4073 lb
 0 lb
 0 lb
 1440 lb
 0 lb
 32 lb
 0 lb

 Structure Total: 8745 lb

Structure Notes:
 STATION: 0+40 (US 79 NEAR 25+50)
 1. HOE MC-315 F/C "Sanitary" PROVIDED BY ICAST.
 2. PER ASTM C478 SPECIFICATIONS.
 3. CONCRETE = 4,000 PSI AT 28 DAYS.
 4. REINFORCING PER ASTM A615 (GRADE 60).
 - CONE (As .12)
 - RISER/WALLS (As .12)
 - FLOOR (As .31) #5 BARS AT 12" C.C.E.W.

Rim: 526.16' Rim to Invert: 7.5' Slack: 1" Sump: 2" Step Position: 0°

Position	Elev	Angle	Ext. (cw)	Pipe	Pipe OD	Connector	Hole	Horz Size	Up ()	Offset
Invert 1	518.66'	0°	0"	8" PVC SDR35	8.5"	PSX 12-08 NYLO	12"	12.129"	0"	0"
Invert 2	518.76'	90°	45.5"	8" PVC SDR35	8.5"	PSX 12-08 NYLO	12"	12.129"	1.25"	0"
Invert 3	518.76'	180°	91.125"	8" PVC SDR35	8.5"	PSX 12-08 NYLO	12"	12.129"	1.25"	0"
Invert 4	518.76'	270°	136.625"	8" PVC SDR35	8.5"	PSX 12-08 NYLO	12"	12.129"	1.25"	0"
Invert 5										
Invert 6										
Invert 7										
Invert 8										

RIGHT-SIDE UP VIEW (int. dimensions)

UPSIDE-DOWN VIEW (int. dimensions)

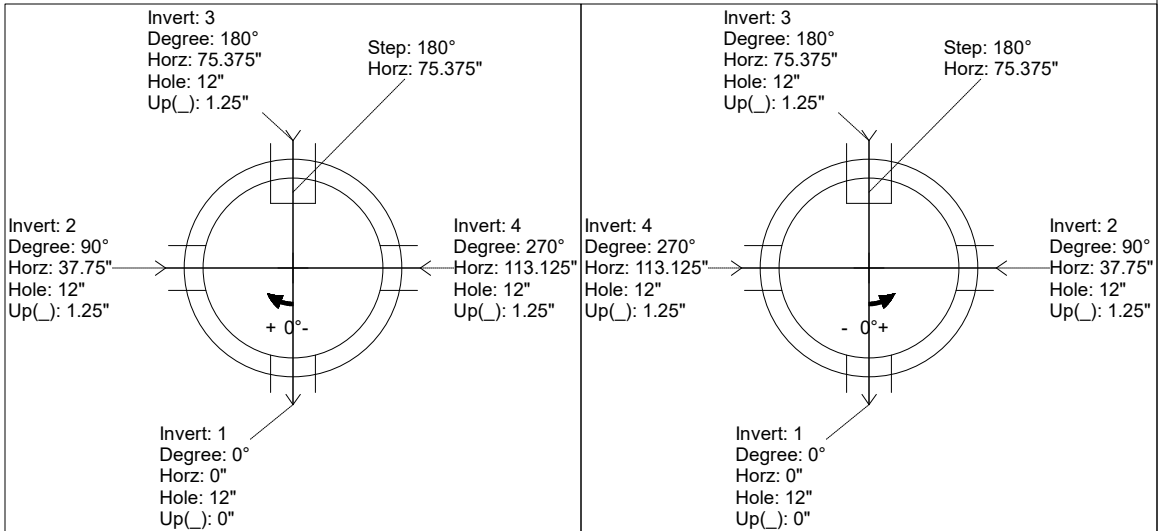
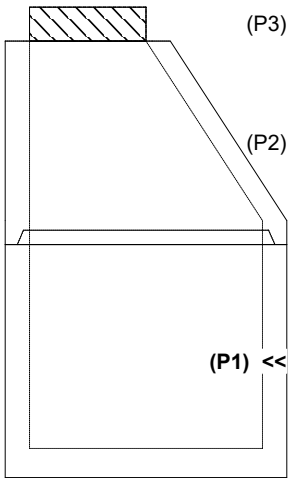

INSIDE WALL DIMENSIONS

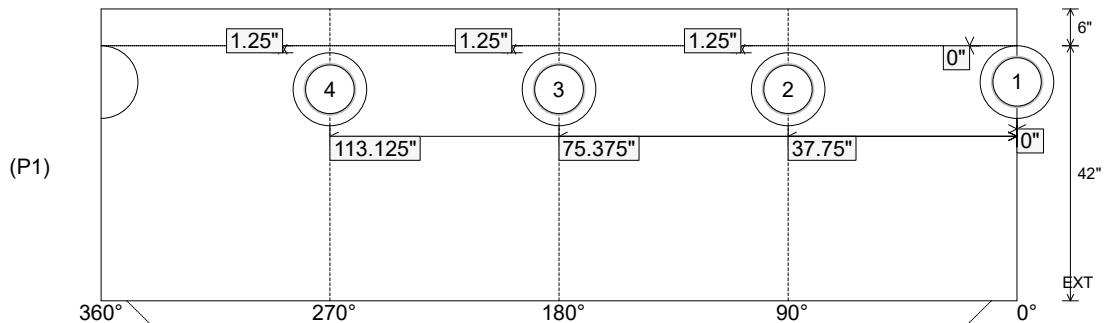

Coating (Int): Coating (Ext):	Seam Up: Tongue Seam Dn: n/a	Wall Thickness: 5" Floor Height: 6"	Height (Int): 42" Height (Ext): 48"	Weight (Net): 4073 lb Volume (Net): 1.04cu.yd
----------------------------------	---------------------------------	--	--	--

Job Name: 25-3194B KYTC Todd Co Call 101 (251113)
 Job Location: Guthrie, KY
 Contractor: Scott & Ritter, Inc.

Plant: 100

11/17/2025 1:48:45 PM

Tech: J. Horsley - A

PC: Celina Goff



Structure ID: 0+40 (29+25 LT)

P1 MH048BA42

MH BASE T/n

- P3) 24" - CASTING HEIGHT - 7"
- P2) 48" - ECC CONE w/ 24" HOLE F/G - 42"
- P1) 48" - MH BASE T/n - 42"
- 1) JOINT WRAP - 0.065"x6"x50' CONSEAL CS212
- 1) JOINT WRAP PRIMER - CONSEAL CS-75 (1 gal.)
- 1) 48" - MH INVERT CHANNEL - FULL HEIGHT
- 1) 48" - Conseal CS-102 1.00" (Double)
- 4) PSX - 12-08 NYLO
- 7) MH Step ML-10-TDS-NCR - 10"

- Structure Notes:**
 STATION: 0+40 (US 79 NEAR 25+50)
 1. HOE MC-315 F/C "Sanitary" PROVIDED BY ICAST.
 2. PER ASTM C478 SPECIFICATIONS.
 3. CONCRETE = 4,000 PSI AT 28 DAYS.
 4. REINFORCING PER ASTM A615 (GRADE 60).
 - CONE (As .12)
 - RISER/WALLS (As .12)
 - FLOOR (As .31) #5 BARS AT 12" C.C.E.W.

Structure Total: 8745 lb

**INVERT CHANNEL DRAWING
 FULL HEIGHT INVERT**

Rim: 526.16' Rim to Invert: 7.5' Slack: 1" Sump: 2" Step Position: 0°

Position	Elev	Angle	Ext. (cw)	Pipe	Pipe OD	Connector	Hole	Horz Size	Up ()	Offset
Invert 1	518.66'	0°	0"	8" PVC SDR35	8.5"	PSX 12-08 NYLO	12"	12.129"	0"	0"
Invert 2	518.76'	90°	45.5"	8" PVC SDR35	8.5"	PSX 12-08 NYLO	12"	12.129"	1.25"	0"
Invert 3	518.76'	180°	91.125"	8" PVC SDR35	8.5"	PSX 12-08 NYLO	12"	12.129"	1.25"	0"
Invert 4	518.76'	270°	136.625"	8" PVC SDR35	8.5"	PSX 12-08 NYLO	12"	12.129"	1.25"	0"
Invert 5										
Invert 6										
Invert 7										
Invert 8										

RIGHT-SIDE UP VIEW (int. dimensions)

UPSIDE-DOWN VIEW (int. dimensions)

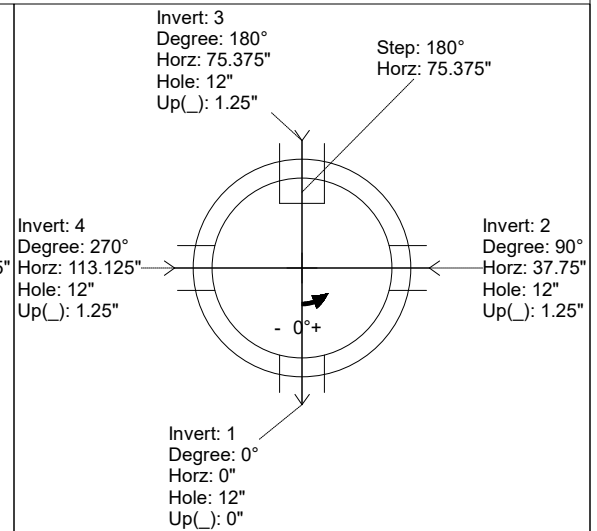
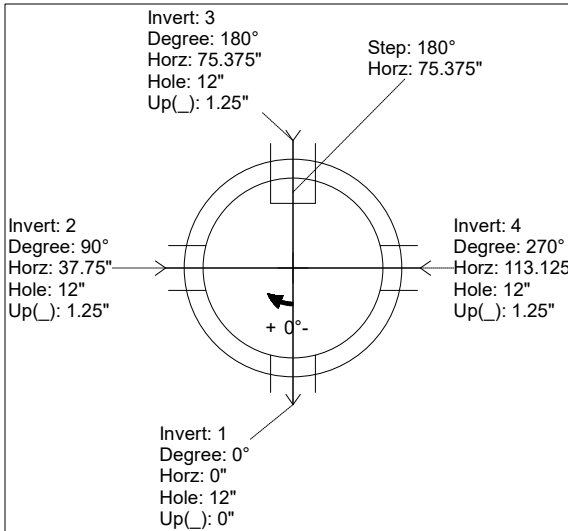
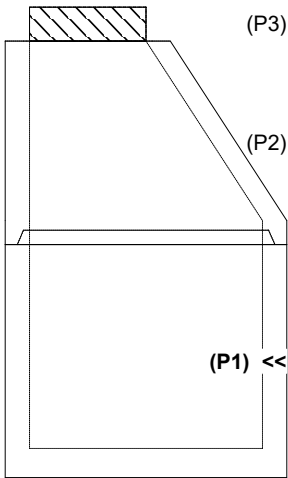

INSIDE WALL DIMENSIONS

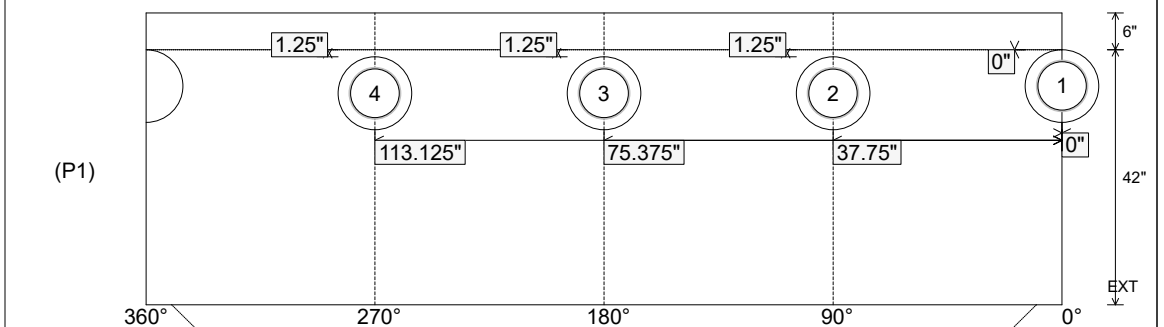

Coating (Int): Coating (Ext):	Seam Up: Tongue Seam Dn: n/a	Wall Thickness: 5" Floor Height: 6"	Height (Int): 42" Height (Ext): 48"	Weight (Net): 4073 lb Volume (Net): 1.04cu.yd
----------------------------------	---------------------------------	--	--	--