

Structure ID: 4637-MH (11)

P1 MH048BAVF

MH BASE Custom Ht T/n

P3) 24" - CASTING HEIGHT - 8" P2) 48" - ECC CONE w/ 24" HOLE F/G - 30" P1) 48" - MH BASE Custom Ht T/n - 33" 1) 48" - Conseal CS-102 1.00" 2) Hole - 22" 6) MH Step ML-10-TDS-NCR - 10"	0 lb 2050 lb 3306 lb 0 lb 0 lb 0 lb ----- Structure Total: 5356 lb
--	---

Structure Notes:
****KYTC STATE PROJECT****
 1. PER KYTC MH A / ASTM C478 SPEC'S.
 2. CONCRETE = 4,000 PSI AT 28 DAYS.
 3. MH A TYPE 2 CASTING BY OTHERS.

REINFORCING PER ASTM A615 (GRADE 60.)
 - TOP SLAB (As .62) #5 BARS AT 6" C.C.E.W..
 - RISER/WALLS (As .12)
 - FLOOR (As .31) #5 BARS AT 12" C.C.E.W.

Rim: 548.07' Rim to Invert: 6.07' Slack: 3.84" Sump: 2" Step Position: 270

Position	Elev	Angle	Ext. (cw)	Pipe	Pipe OD	Connector	Hole	Horz Size	Up ()	Offset
Invert 1	542'	0°	0"	18" CMP	19"	Hole 22	22"	22.854"	0"	0"
Invert 2	542'	120°	60.737"	18" CMP	19"	Hole 22	22"	22.854"	0"	0"
Invert 3										
Invert 4										
Invert 5										
Invert 6										
Invert 7										
Invert 8										

RIGHT-SIDE UP VIEW (int. dimensions)

UPSIDE-DOWN VIEW (int. dimensions)

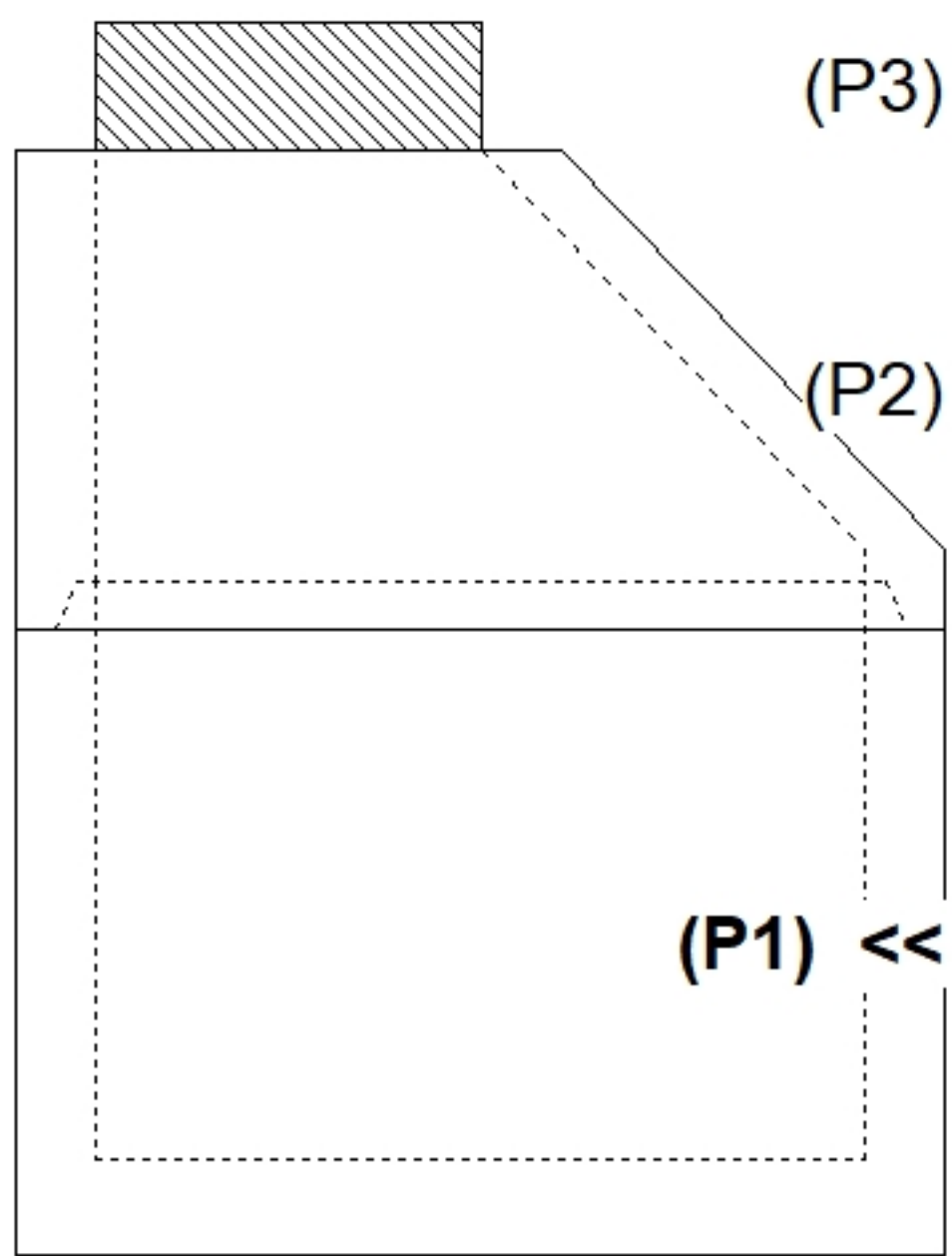
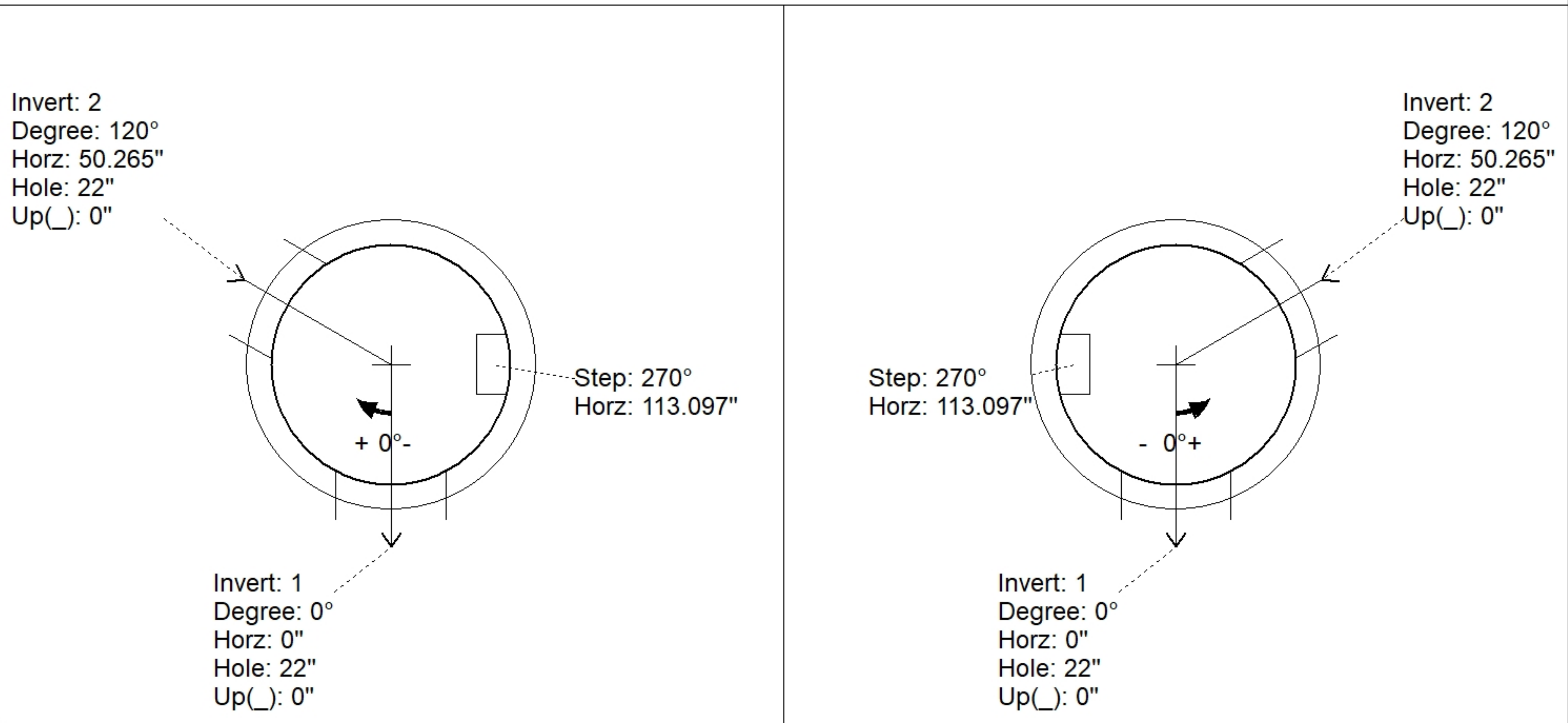

INSIDE WALL DIMENSIONS

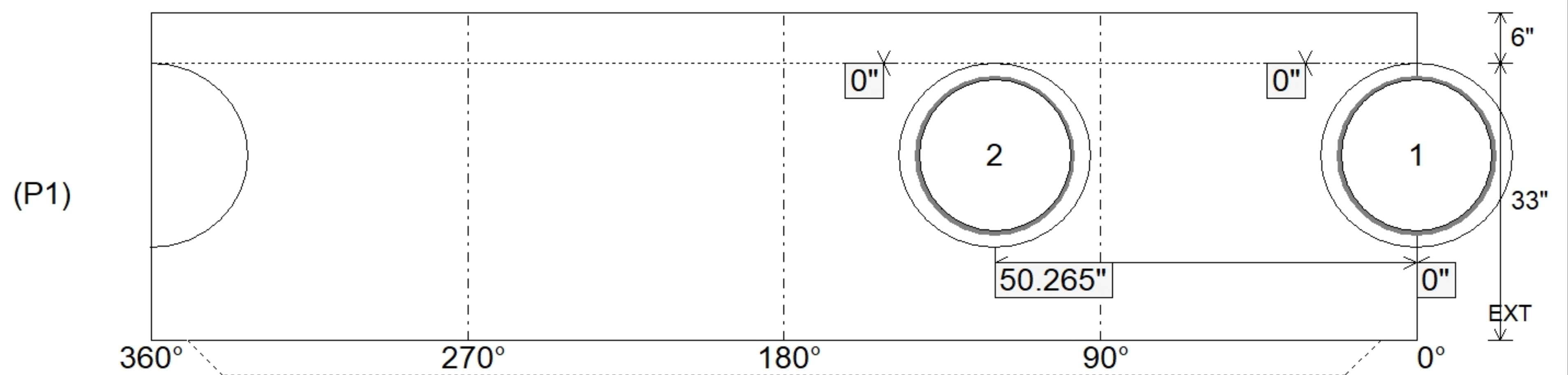

Coating (Int): Coating (Ext):	Seam Up: Tongue Seam Dn: n/a	Wall Thickness: 5" Floor Height: 6"	Height (Int): 33" Height (Ext): 39"	Weight (Net): 3306 lb Volume (Net): 0.84cu.yd
----------------------------------	---------------------------------	--	--	--