

Job Name: 25-3182 - Silverstone Subdivision
 Job Location: Bowling Green, KY
 Contractor: R.A. Alexander & Sons, Inc.

Plant: 100

3/10/2026 9:41:23 AM

Tech: Jared - F

PC: T. Lewis



Structure ID: A5

P1 MH048BA36

MH BASE

- P4) 24" - CASTING HEIGHT - 7"
- P3) 24" - GRADE RING - 4"
- P2) 48" - ECC CONE w/ 24" HOLE - 36"
- P1) 48" - MH BASE - 36"
- 1) JOINT WRAP - 12" WD x 048" MAC WRAP
- 1) 48" - MH INVERT CHANNEL - FULL HEIGHT
- 1) CASTING - HOE MC-375 F/C Sanitary
- 1) 48" - Conseal CS-102 1.00" (Double)
- 2) A-Lok - 0285
- 2) A-Lok - 0200
- 5) MH Step ML-10-TDS-NCR - 10"

- Structure Notes:**
1. PER ASTM C478 SPECIFICATIONS.
 2. CONCRETE = 4,000 PSI AT 28 DAYS.
 3. CASTING BY ICAST (HOE MC-375 F/C SANITARY).

- REINFORCING PER ASTM A615 (GRADE 60).**
- CONE (As .12)
 - RISER/WALLS (As .12)
 - FLOOR (As .31) #5 BARS AT 12" C.C.E.W.

Structure Total: 8735 lb

Rim: 556.7' Rim to Invert: 6.78' Slack: 0.36" Sump: 2" Step Position: 0°

Position	Elev	Angle	Ext. (cw)	Pipe	Pipe OD	Connector	Hole	Horz Size	Up ()	Offset
Invert 1	549.92'	0°	0"	8" PVC SDR35	8.5"	A-Lok 0285	9.75"	9.818"	1.125"	0"
Invert 2	550.02'	90°	45.553"	8" PVC SDR35	8.5"	A-Lok 0285	9.75"	9.818"	2.325"	0"
Invert 3	550.12'	190°	96.168"	6" PVC SDR35	6.25"	A-Lok 0200	7"	7.025"	3.9"	0"
Invert 4	550.12'	240°	121.475"	6" PVC SDR35	6.25"	A-Lok 0200	7"	7.025"	3.9"	0"
Invert 5										
Invert 6										
Invert 7										
Invert 8										

RIGHT-SIDE UP VIEW (int. dimensions)

UPSIDE-DOWN VIEW (int. dimensions)

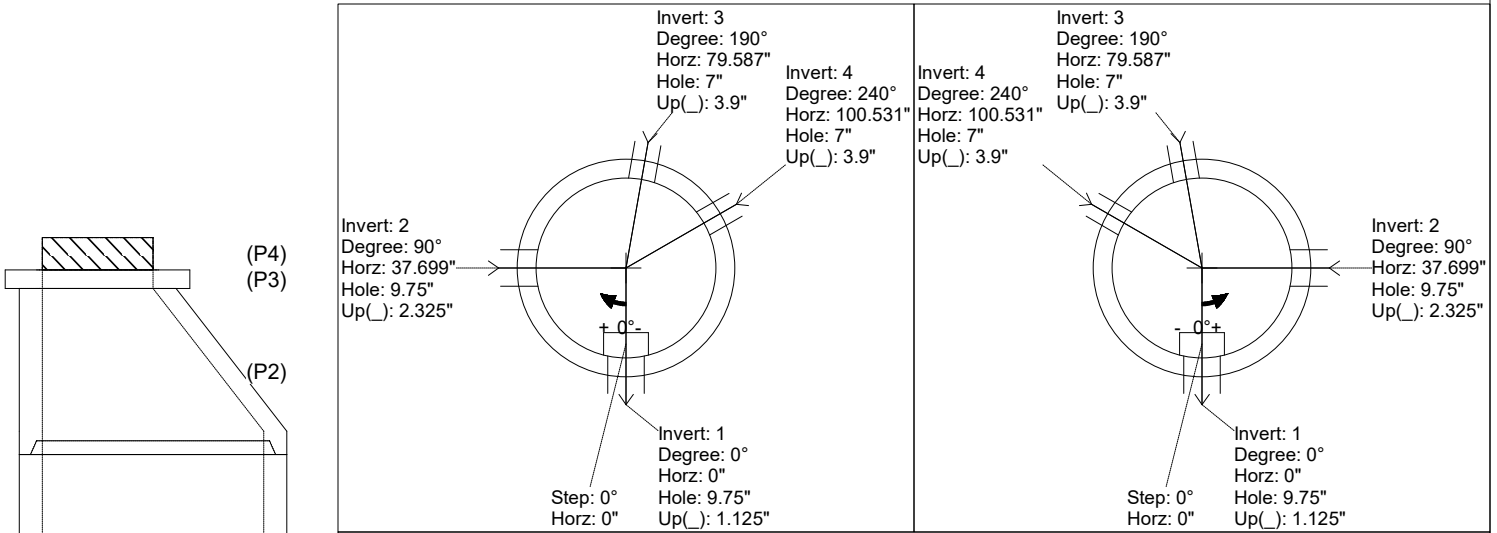

INSIDE WALL DIMENSIONS

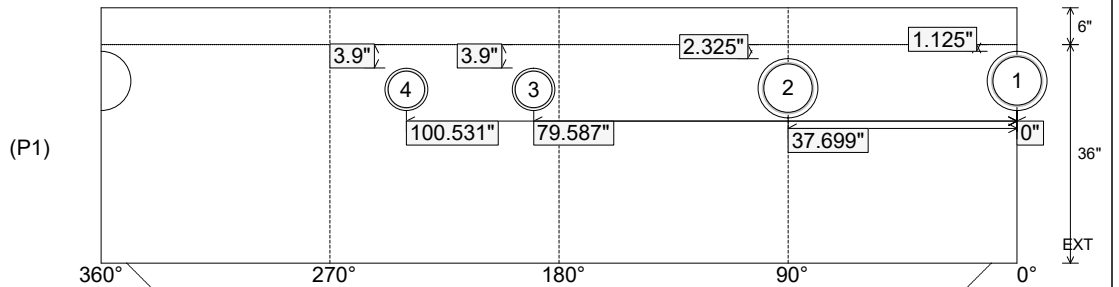

Coating (Int):
 Coating (Ext):

Seam Up: Tongue
 Seam Dn: n/a

Wall Thickness: 5"
 Floor Height: 6"

Height (Int): 36"
 Height (Ext): 42"

Weight (Net): 3750 lb
 Volume (Net): 0.96cu.yd

Job Name: 25-3182 - Silverstone Subdivision
 Job Location: Bowling Green, KY
 Contractor: R.A. Alexander & Sons, Inc.

Plant: 100

3/10/2026 9:41:23 AM

Tech: Jared - F

PC: T. Lewis



Structure ID: A5

P1 MH048BA36

MH BASE

- P4) 24" - CASTING HEIGHT - 7"
- P3) 24" - GRADE RING - 4"
- P2) 48" - ECC CONE w/ 24" HOLE - 36"
- P1) 48" - MH BASE - 36"
- 1) JOINT WRAP - 12" WD x 048" MAC WRAP
- 1) 48" - MH INVERT CHANNEL - FULL HEIGHT
- 1) CASTING - HOE MC-375 F/C Sanitary
- 1) 48" - Conseal CS-102 1.00" (Double)
- 2) A-Lok - 0285
- 2) A-Lok - 0200
- 5) MH Step ML-10-TDS-NCR - 10"

- Structure Notes:**
1. PER ASTM C478 SPECIFICATIONS.
 2. CONCRETE = 4,000 PSI AT 28 DAYS.
 3. CASTING BY ICAST (HOE MC-375 F/C SANITARY).

- REINFORCING PER ASTM A615 (GRADE 60).**
- CONE (As .12)
 - RISER/WALLS (As .12)
 - FLOOR (As .31) #5 BARS AT 12" C.C.E.W.

**INVERT CHANNEL DRAWING
 FULL HEIGHT INVERT**

Structure Total: 8735 lb

Rim: 556.7' Rim to Invert: 6.78' Slack: 0.36" Sump: 2" Step Position: 0°

Position	Elev	Angle	Ext. (cw)	Pipe	Pipe OD	Connector	Hole	Horz Size	Up ()	Offset
Invert 1	549.92'	0°	0"	8" PVC SDR35	8.5"	A-Lok 0285	9.75"	9.818"	1.125"	0"
Invert 2	550.02'	90°	45.553"	8" PVC SDR35	8.5"	A-Lok 0285	9.75"	9.818"	2.325"	0"
Invert 3	550.12'	190°	96.168"	6" PVC SDR35	6.25"	A-Lok 0200	7"	7.025"	3.9"	0"
Invert 4	550.12'	240°	121.475"	6" PVC SDR35	6.25"	A-Lok 0200	7"	7.025"	3.9"	0"
Invert 5										
Invert 6										
Invert 7										
Invert 8										

RIGHT-SIDE UP VIEW (int. dimensions)

UPSIDE-DOWN VIEW (int. dimensions)

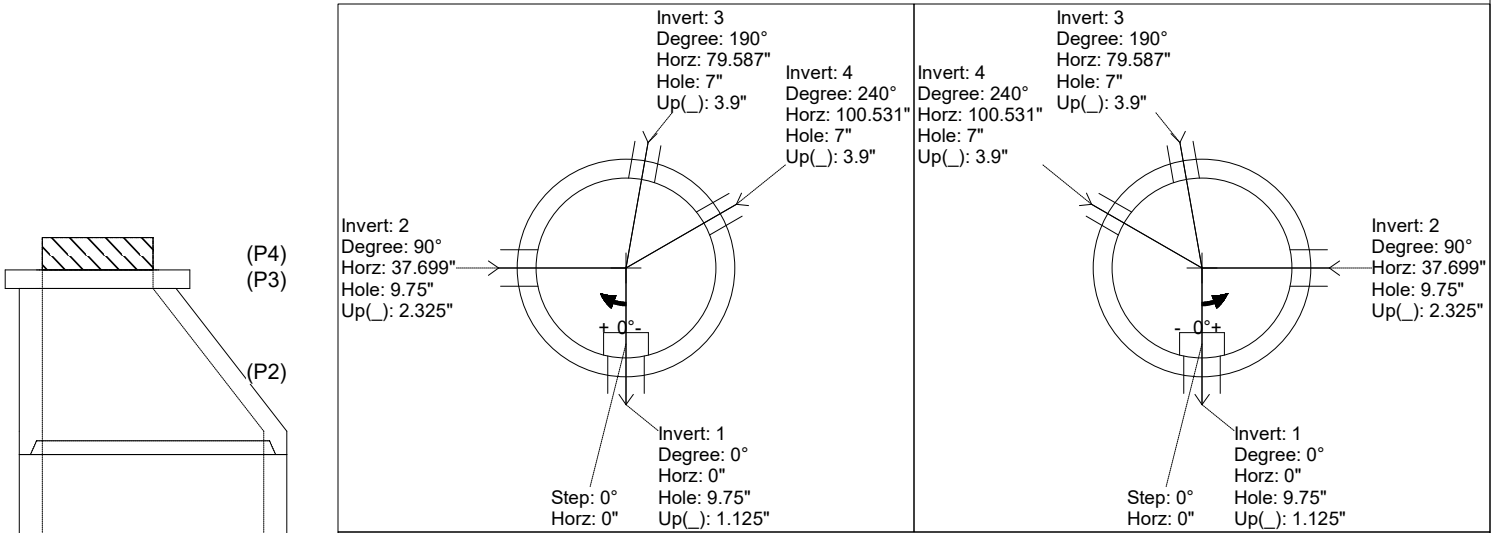

INSIDE WALL DIMENSIONS

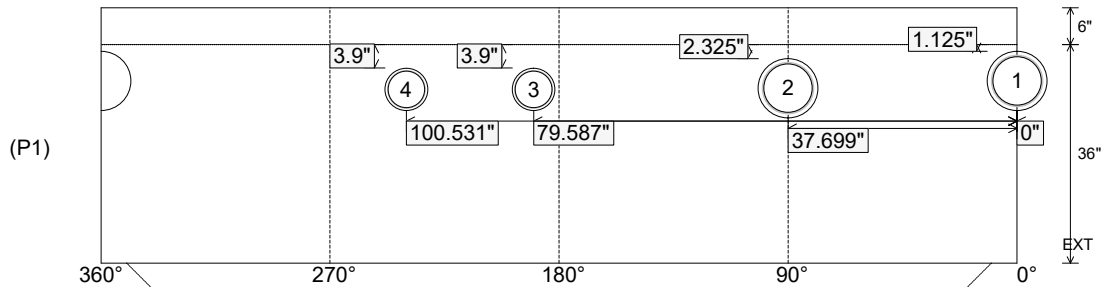

Coating (Int):
 Coating (Ext):

Seam Up: Tongue
 Seam Dn: n/a

Wall Thickness: 5"
 Floor Height: 6"

Height (Int): 36"
 Height (Ext): 42"

Weight (Net): 3750 lb
 Volume (Net): 0.96cu.yd