

Job Name: 25-3182 - Silverstone Subdivision
 Job Location: Bowling Green, KY
 Contractor: R.A. Alexander & Sons, Inc.

Plant: 100

3/10/2026 9:41:50 AM

Tech: Jared - F

PC: T. Lewis



Structure ID: A2

P4 GR4

GRADE RING

- P5) 24" - CASTING HEIGHT - 7"
- P4) 24" - GRADE RING - 4"
- P3) 48" - ECC CONE w/ 24" HOLE - 42"
- P2) 48" - MH RISER - 72"
- P1) 48" - MH BASE - 36"
- 1) JOINT WRAP - 12" WD x 048" MAC WRAP
- 1) 48" - MH INVERT CHANNEL - FULL HEIGHT
- 1) CASTING - HOE MC-375 F/C Sanitary
- 2) 48" - Conseal CS-102 1.00" (Double)
- 2) A-Lok - 0285
- 12) MH Step ML-10-TDS-NCR - 10"

0 lb	Structure Notes: 1. PER ASTM C478 SPECIFICATIONS. 2. CONCRETE = 4,000 PSI AT 28 DAYS. 3. CASTING BY ICAST (HOE MC-375 F/C SANITARY). REINFORCING PER ASTM A615 (GRADE 60). - CONE (As .12) - RISER/WALLS (As .12) - FLOOR (As .31) #5 BARS AT 12" C.C.E.W.
270 lb	
3200 lb	
5030 lb	
3782 lb	
0 lb	
1440 lb	
271 lb	
0 lb	
2 lb	
0 lb	Structure Total: 13995 lb

NOTES:

1. GRADE RINGS MEET OR EXCEED THE FOLLOWING SPECIFICATIONS:
 -CONCRETE: 4,000 PSI @ 28 DAYS.
 -REINFORCING: (1) #3 HOOP CENTERED (GRADE 60)

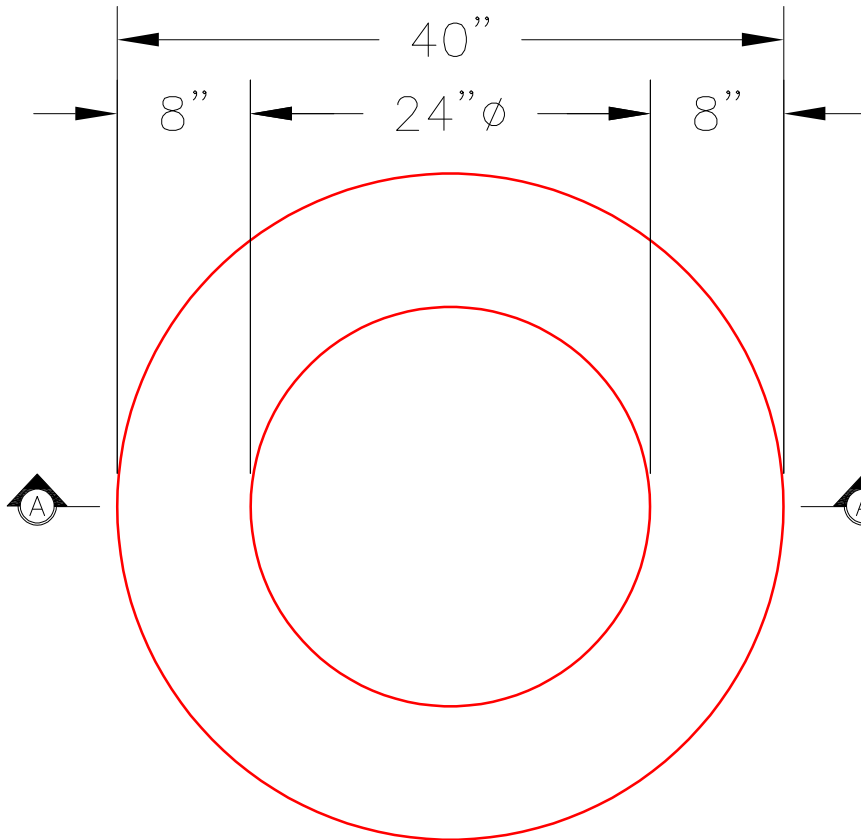

PLAN VIEW

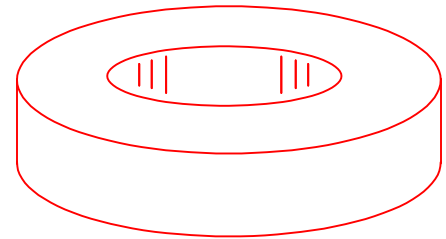

ISOMETRIC VIEW

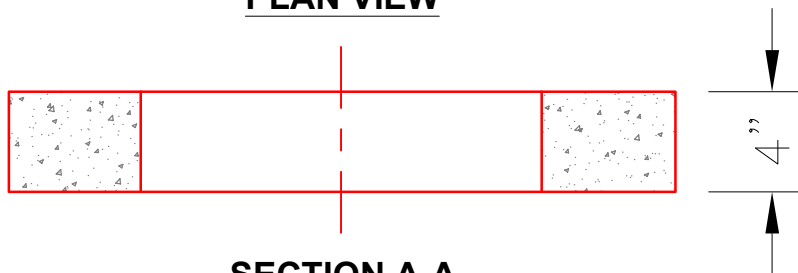

SECTION A-A

Coating (Int):
 Coating (Ext):

Seam Up: Flat
 Seam Dn: Flat

Wall Thickness: 8"

Height (Ext): 4"

Weight (Net): 270 lb
 Volume (Net): 0.07cu.yd