

Job Name: 25-3175 - MSU MDAB  
 Job Location: Morehead, KY 40351  
 Contractor: Rising Sun Development Company

Plant: Beaver Dam, KY  
 10/28/2025 8:29:34 PM

Tech: K. Cardwell  
 PC: J. Jarvis



**Structure ID: MH3**

**P1 MH048BA48**

**MH BASE T/n**

- P5) 24" - CASTING HEIGHT - 7"
- P4) 24" - GRADE RING F/F - 3"
- P3) 48" - ECC CONE w/ 24" HOLE F/G - 42"
- P2) 48" - MH RISER T/G - 36"
- P1) 48" - MH BASE T/n - 48"
- 2) 48" - Conseal CS-102 1.00"
- 1) Hole - 20
- 1) Hole - 16
- 11) MH Step ML-10-TDS-NCR - 10"

0 lb  
 202 lb  
 3200 lb  
 2515 lb  
 4462 lb  
 0 lb  
 0 lb  
 0 lb  
 0 lb  
 0 lb  
 Structure Total: 10380 lb

**Structure Notes:**  
 PLAN LABEL: MH-3A  
 1. PER ASTM C-478 SPECS  
 2. CONCRETE: 4,000 PSI AT 28 DAYS  
 3. REINFORCEMENT: PER ASTM A615  
 4. STEPS AT 100 DEGREES  
 5. 7" CASTING SUPPLIED BY OTHERS

Rim: 748.01' Rim to Invert: 11.37' Slack: 0.44" Sump: 0" Step Position: 100

Position	Elev	Angle	Ext. (cw)	Pipe	Pipe OD	Connector	Hole	Horz Size	Up ( )	Offset
Invert 1	736.64'	0°	0"	15" ADS N-12	18"	Hole 20	20"	20.629"	-1.5"	0"
Invert 2	736.64'	201°	101.735"	12" ADS N-12	14.5"	Hole 16	16"	16.312"	-1.25"	0"
Invert 3										
Invert 4										
Invert 5										
Invert 6										
Invert 7										
Invert 8										

RIGHT-SIDE UP VIEW (int. dimensions)

UPSIDE-DOWN VIEW (int. dimensions)

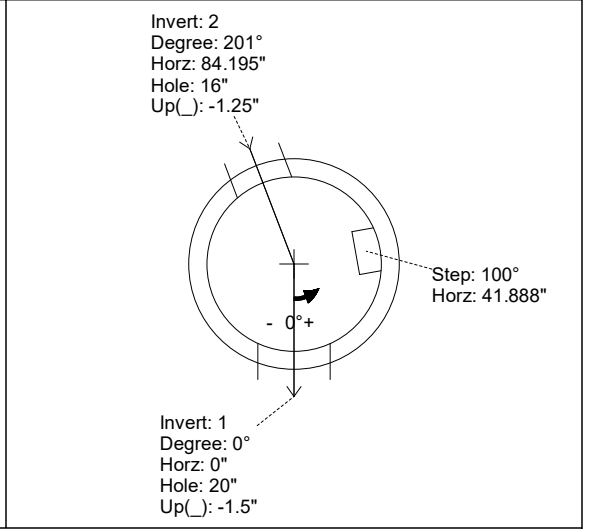
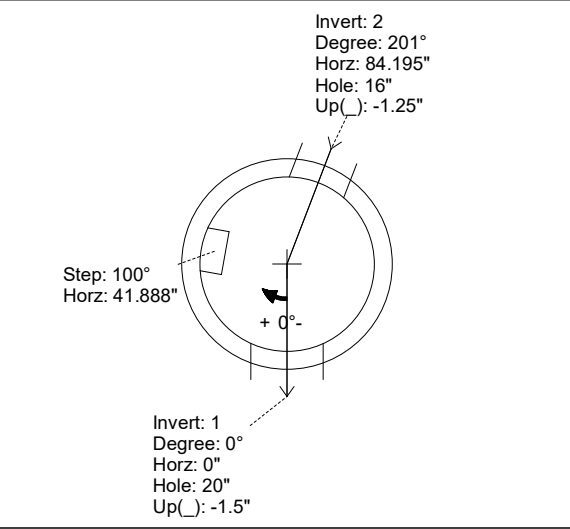
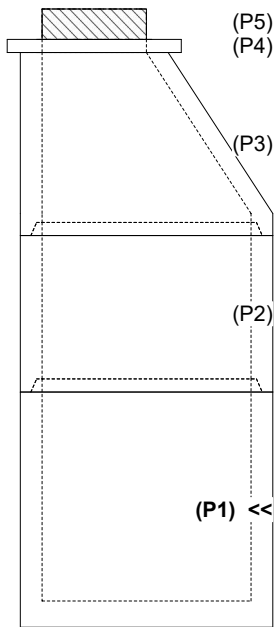

INSIDE WALL DIMENSIONS

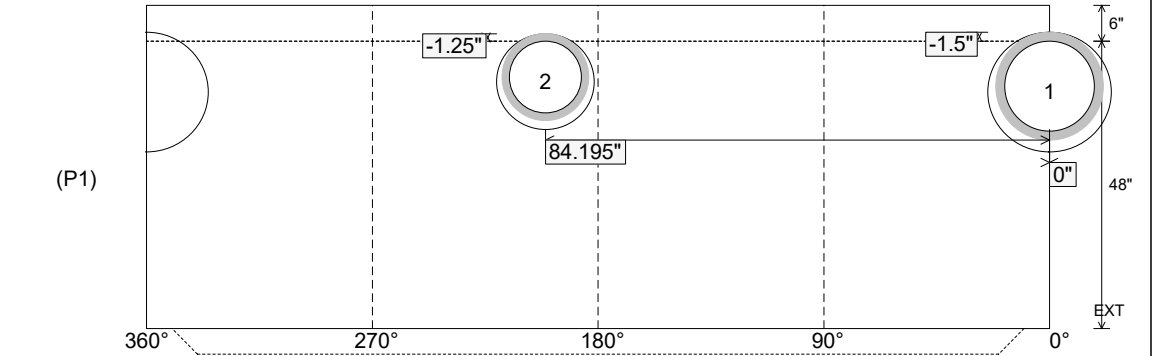

Coating (Int):  
 Coating (Ext):

Seam Up: Tongue  
 Seam Dn: n/a

Wall Thickness: 5"  
 Floor Height: 6"

Height (Int): 48"  
 Height (Ext): 54"

Weight (Net): 4462 lb  
 Volume (Net): 1.14cu.yd