

Job Name: 25-3175 - MSU MDAB
 Job Location: Morehead, KY 40351
 Contractor: Rising Sun Development Company

Plant: Beaver Dam, KY
 10/28/2025 8:29:32 PM

Tech: K. Cardwell
 PC: J. Jarvis



Structure ID: MH1

P1 MH072BAVF

MH BASE Custom Ht F/n

- P3) 24" - CASTING HEIGHT - 7"
- P2) 72" - MH FLAT LID w/24in ECC Hole F/F - 10"
- P1) 72" - MH BASE Custom Ht F/n - 67"
- 1) 72" - Conseal CS-102 1.00"
- 1) Hole - 30
- 2) Hole - 24
- 2) Hole - 20
- 4) MH Step ML-10-TDS-NCR - 10"

0 lb
 4495 lb
 12301 lb
 0 lb
 0 lb
 0 lb
 0 lb
 0 lb

 Structure Total: 16796 lb

- Structure Notes:**
 PLAN LABEL: MH-1A
1. PER ASTM C-478 SPECS
 2. CONCRETE: 4,000 PSI AT 28 DAYS
 3. REINFORCEMENT: PER ASTM A615
 4. STEPS AT 135 DEGREES
 5. 7" CASTING SUPPLIED BY OTHERS
 6. INVERT 1 OFFSET 9" FROM CENTER
 7. INVERT 2 OFFSET 10" FROM CENTER

Rim: 732.34' Rim to Invert: 5.04' Slack: 0.48" Sump: 24" Step Position: 135°

Position	Elev	Angle	Ext. (cw)	Pipe	Pipe OD	Connector	Hole	Horz Size	Up (")	Offset
Invert 1	727.3'	0°	-9.067"	24" ADS N-12	28"	Hole 30	30"	32.298"	22"	-9"
Invert 2	728'	20°	25.102"	18" ADS N-12	22"	Hole 24	24"	25.67"	30.4"	10"
Invert 3	727.61'	90°	67.544"	15" ADS N-12	18"	Hole 20	20"	20.267"	26.22"	0"
Invert 4	727.61'	180°	135.088"	15" ADS N-12	18"	Hole 20	20"	20.267"	26.22"	0"
Invert 5	728.28'	270°	202.633"	18" ADS N-12	22"	Hole 24	24"	24.468"	33.76"	0"
Invert 6										
Invert 7										
Invert 8										

RIGHT-SIDE UP VIEW (int. dimensions)

UPSIDE-DOWN VIEW (int. dimensions)

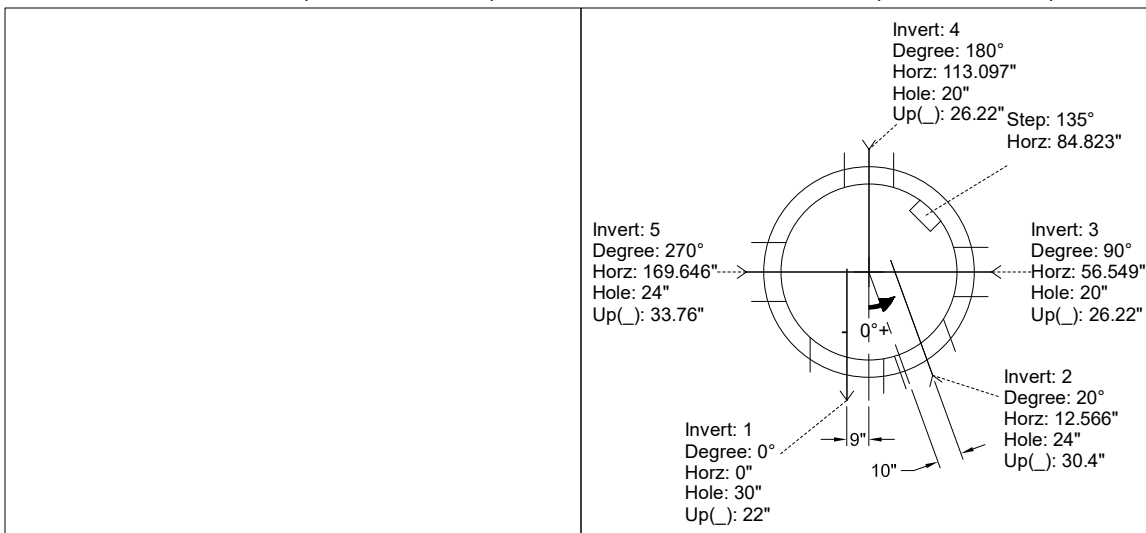
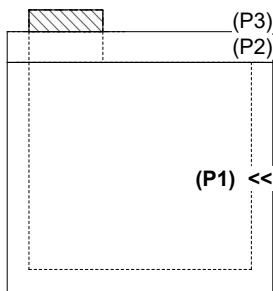

INSIDE WALL DIMENSIONS

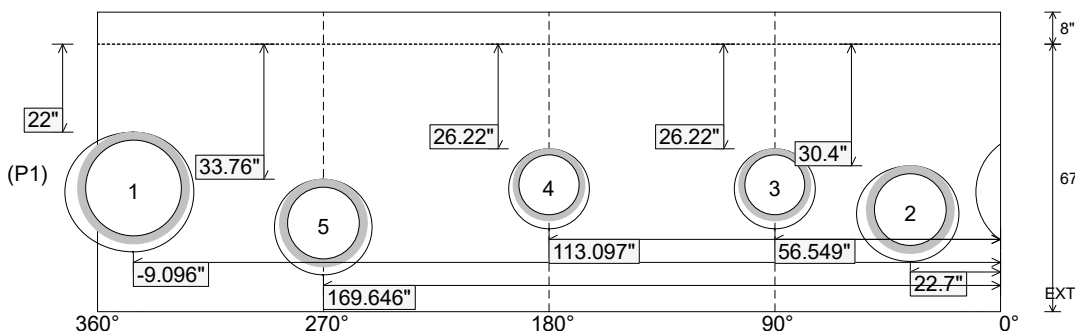

Coating (Int):
 Coating (Ext):

Seam Up: Flat
 Seam Dn: n/a

Wall Thickness: 7"
 Floor Height: 8"

Height (Int): 67"
 Height (Ext): 75"

Weight (Net): 12301 lb
 Volume (Net): 3.14cu.yd