

Job Name: 25-3170 - Publix BG
 Job Location: Bowling Green, KY
 Contractor: Scotty's Contracting & Stone, LLC

Plant: Beaver Dam, KY

Tech: K. Cardwell

10/9/2025 7:48:40 AM

PC: C. Goff



Structure ID: CBI6

P2 MH048LD12-24SQ

MH FLAT TOP w/24"x24" Hole F/G

- P3) 24" x 24" - CASTING HEIGHT - 5"
- P2) 48" - MH FLAT TOP w/24"x24" Hole F/G - 12"
- P1) 48" - MH BASE T/n - 72"
- 1) CASTING - HOE KY-465 SET (CBI TY F)
- 1) 48" - Conseal CS-102 1.00"
- 1) 24" x 24" - Conseal CS-102 1.00"
- 2) Hole - 30
- 6) MH Step ML-10-TDS-NCR - 10"

- 0 lb
- 2080 lb
- 5728 lb
- 465 lb
- 0 lb
- 0 lb
- 0 lb
- 0 lb
- 0 lb
- Structure Total: 8273 lb

- Structure Notes:**
 PLAN LABEL: CBI 6
1. PER ASTM C-478 SPECS
 2. CONCRETE: 4,000 PSI AT 28 DAYS
 3. REINFORCEMENT: #4 BAR @ 10" C.C. E.W. (GRADE 60) - 2" MIN. REBAR CLEARANCE (TYP)
 4. STEPS AT 210 DEGREES
 5. KY 465 FRAME, GRATE, & CURB BOX SUPPLIED BY ICAST
 6. LIFTERS: 4 EA. WRA016 CONAC WIRE ROPE ANCHORS FOR PLANT & FIELD HANDLING

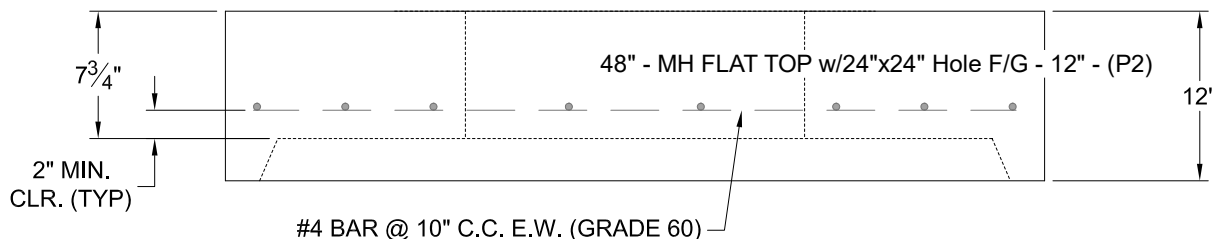
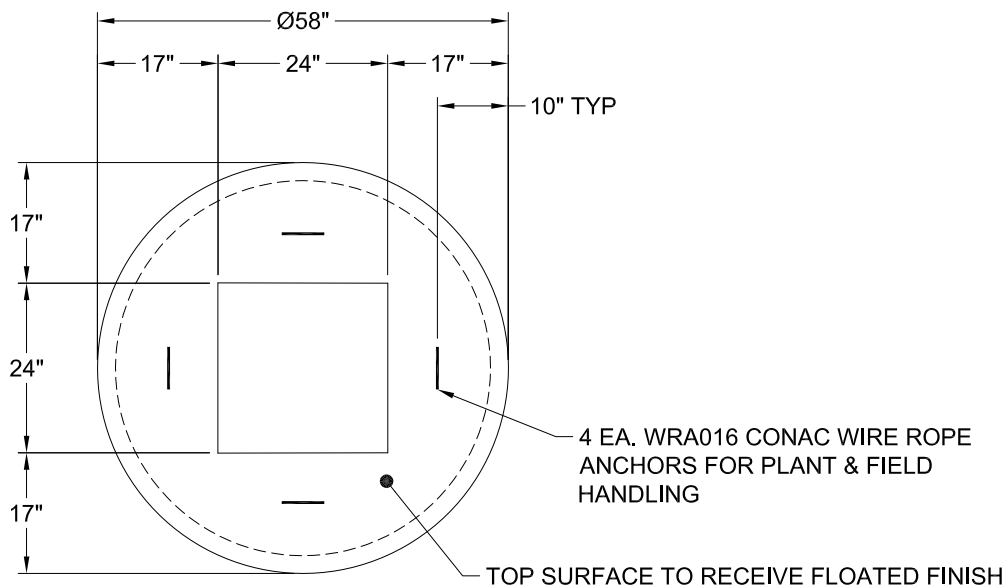

Coating (Int):
 Coating (Ext):

Seam Up: Flat
 Seam Dn: Groove

Wall Thickness: 5"

Height (Ext): 12"

Weight (Net): 1500 lb
 Volume (Net): 0.37cu.yd