

Job Name: 25-3118 - W6 Ph 2-C Force Main Improvements  
 Job Location: Fort Mitchell, KY 41017  
 Contractor: Lykins Contracting

Plant: 100

3/27/2026 11:39:42 AM

Tech: J. Horsley - A

PC: Celina Goff

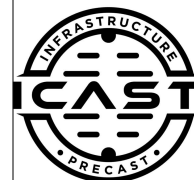

**Structure ID: 2301583**

**P2 MH060TS15-48ECC**

**MH Transition Slab 48" Hole T/G**

- P6) 24" - CASTING HEIGHT - 7"
- P5) 24" - GRADE RING F/F - 6"
- P4) 48" - CON CONE w/24" HOLE F/G - 24"
- P3) 48" - MH RISER T/G - 48"
- P2) 60" - MH Transition Slab 48" Hole T/G - 15"
- P1) 60" - MH BASE T/n - 72"
- 1) 60" - MH INVERT CHANNEL - FULL HEIGHT
- 1) 60" - Conseal CS-102 1.00" (Double)
- 2) 48" - Conseal CS-102 1.00" (Double)
- 2) A-Lok - 1235
- 12) MH Step ML-10-TDS-NCR - 10"

- 0 lb
- 405 lb
- 2252 lb
- 3353 lb
- 2204 lb
- 8895 lb
- 2692 lb
- 0 lb
- 0 lb
- 2 lb
- 0 lb
- Structure Total: 19803 lb

- Structure Notes:
1. PER ASTM C-478 SPECIFICATIONS
  2. CONCRETE: 4,000 PSI AT 28 DAYS
  3. REINFORCEMENT - 2" MIN. REBAR CLEARANCE (TYP):
    - TOP MAT: #4 BAR @ 18" C.C. E.W. (GRADE 60)
    - BOTTOM MAT: #4 BAR @ 9" C.C. E.W. (GRADE 60)
  4. 7" CASTING SUPPLIED BY OTHERS
  5. LIFTERS: 3 EA. WRA016 CONAC WIRE ROPE ANCHORS FOR PLANT & FIELD HANDLING
  6. TOP SURFACE TO RECEIVE FLOATED FINISH

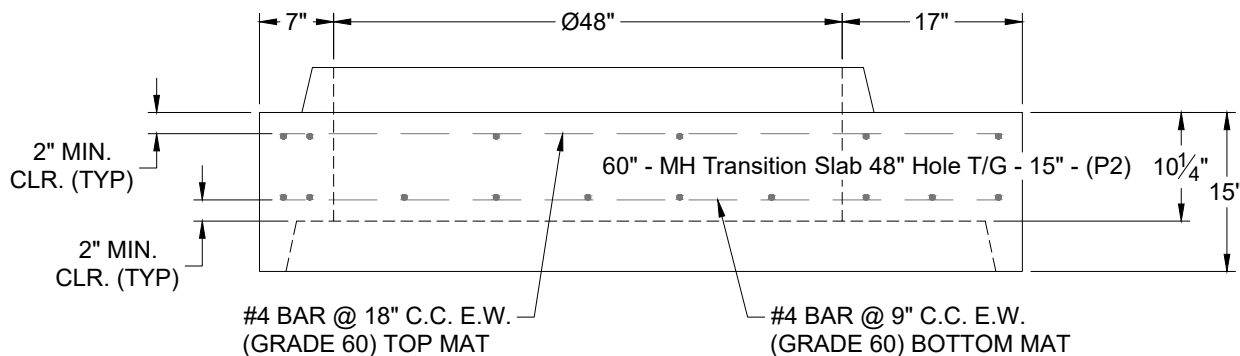
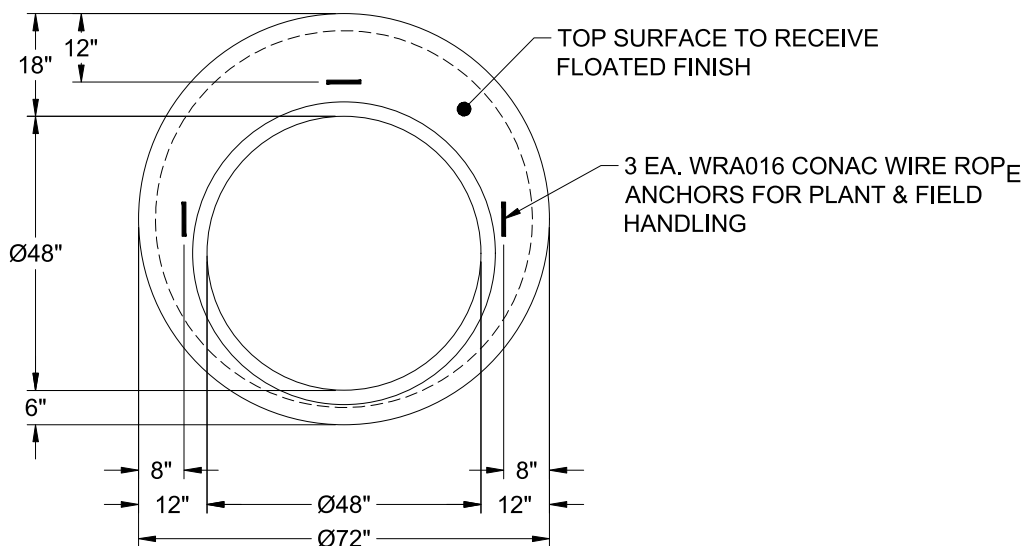

Coating (Int):  
Coating (Ext):

Seam Up: Tongue  
Seam Dn: Groove

Wall Thickness: 6"

Height (Ext): 15"

Weight (Net): 2204 lb  
Volume (Net): 0.56cu.yd