

Job Name: 25-3118 - W6 Ph 2-C Force Main Improvements  
 Job Location: Fort Mitchell, KY 41017  
 Contractor: Lykins Contracting

Plant: 100

3/20/2026 1:22:22 PM

Tech: J. Horsley - A

PC: Celina Goff



**Structure ID: 2301579**

**P1 MH048BA24**

**MH BASE (08"F) T/n**

- P5) 24" - CASTING HEIGHT - 7"
- P4) 48" - CON CONE w/24" HOLE F/G - 24"
- P3) 48" - MH RISER T/G - 48"
- P2) 48" - MH RISER T/G - 60"
- P1) 48" - MH BASE (08"F) T/n - 24"
- 1) 48" - MH INVERT CHANNEL - FULL HEIGHT
- 3) 48" - Conseal CS-102 1.00" (Double)
- 2) PSX - 12-08 NYLO
- 12) MH Step ML-10-TDS-NCR - 10"

0 lb  
 2252 lb  
 3353 lb  
 4192 lb  
 3354 lb  
 1440 lb  
 0 lb  
 16 lb  
 0 lb  
 -----  
 Structure Total: 14607 lb

Structure Notes:

1. PER ASTM C-478 SPECIFICATIONS
2. CONCRETE: 4,000 PSI AT 28 DAYS
3. REINFORCEMENT:
  - WALLS: PER ASTM A615 - DOUBLE MAT
  - FLOOR: #5 BAR @ 12" C.C. E.W. (GRADE 60) - 2" MIN. REBAR CLEARANCE (TYP)
4. INVERT CHANNEL REQUIRED
5. STEPS AT 90 DEGREES
6. 7" CASTING SUPPLIED BY OTHERS

Rim: 791' Rim to Invert: 13.63' Slack: 2.56" Sump: 2" Step Position: 90°

Position	Elev	Angle	Ext. (cw)	Pipe	Pipe OD	Connector	Hole	Horz Size	Up ( )	Offset
Invert 1	777.37'	0°	0"	8" PVC SDR35	8.5"	PSX 12-08 NYLO	12"	12.129"	0"	0"
Invert 2	777.47'	233°	117.875"	8" PVC SDR35	8.5"	PSX 12-08 NYLO	12"	12.129"	1.25"	0"
Invert 3										
Invert 4										
Invert 5										
Invert 6										
Invert 7										
Invert 8										

RIGHT-SIDE UP VIEW (int. dimensions)

UPSIDE-DOWN VIEW (int. dimenions)

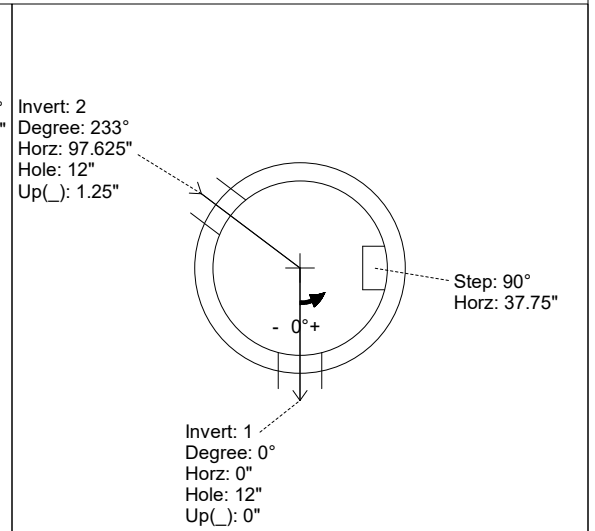
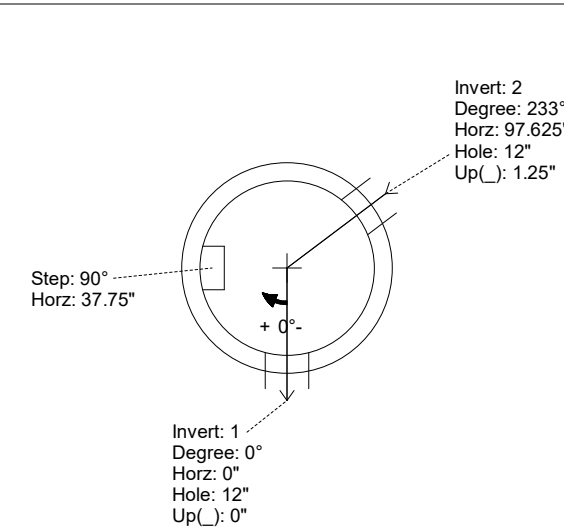
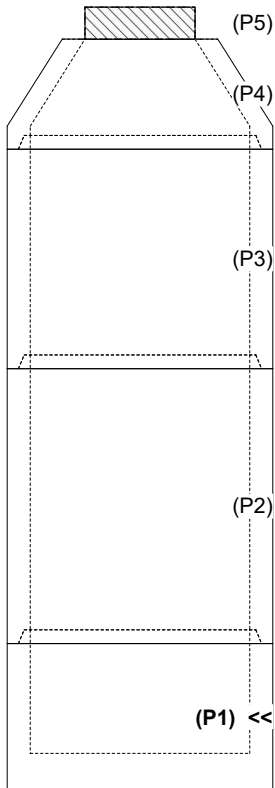

INSIDE WALL DIMENSIONS

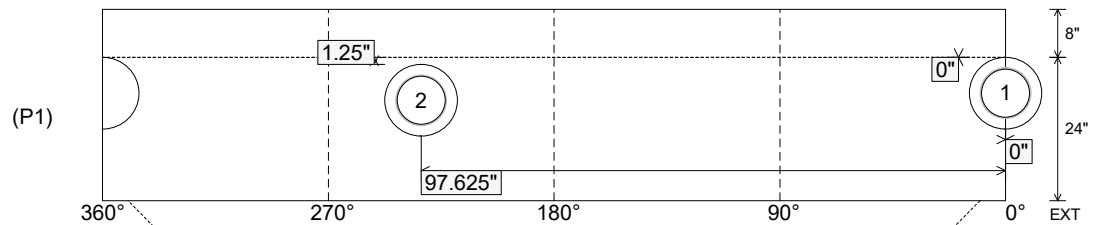

Coating (Int):  
 Coating (Ext):

Seam Up: Tongue  
 Seam Dn: n/a

Wall Thickness: 5"  
 Floor Height: 8"

Height (Int): 24"  
 Height (Ext): 32"

Weight (Net): 3354 lb  
 Volume (Net): 0.86cu.yd

Job Name: 25-3118 - W6 Ph 2-C Force Main Improvements  
 Job Location: Fort Mitchell, KY 41017  
 Contractor: Lykins Contracting

Plant: 100

Tech: J. Horsley - A

3/20/2026 1:22:22 PM

PC: Celina Goff



**Structure ID: 2301579**

**P1 MH048BA24**

**MH BASE (08"F) T/n**

- P5) 24" - CASTING HEIGHT - 7"
- P4) 48" - CON CONE w/24" HOLE F/G - 24"
- P3) 48" - MH RISER T/G - 48"
- P2) 48" - MH RISER T/G - 60"
- P1) 48" - MH BASE (08"F) T/n - 24"
- 1) 48" - MH INVERT CHANNEL - FULL HEIGHT
- 3) 48" - Conseal CS-102 1.00" (Double)
- 2) PSX - 12-08 NYLO
- 12) MH Step ML-10-TDS-NCR - 10"

0 lb  
 2252 lb  
 3353 lb  
 4192 lb  
 3354 lb  
 1440 lb  
 0 lb  
 16 lb  
 0 lb  
 -----  
 Structure Total: 14607 lb

- Structure Notes:**
1. PER ASTM C-478 SPECIFICATIONS
  2. CONCRETE: 4,000 PSI AT 28 DAYS
  3. REINFORCEMENT:
    - WALLS: PER ASTM A615 - DOUBLE MAT
    - FLOOR: #5 BAR @ 12" C.C. E.W. (GRADE 60) - 2" MIN. REBAR CLEARANCE (TYP)
  4. INVERT CHANNEL REQUIRED
  5. STEPS AT 90 DEGREES
  6. 7" CASTING SUPPLIED BY OTHERS

Rim: 791' Rim to Invert: 13.63' Slack: 2.56" Sump: 2" Step Position: 90°

Position	Elev	Angle	Ext. (cw)	Pipe	Pipe OD	Connector	Hole	Horz Size	Up ( )	Offset
Invert 1	777.37'	0°	0"	8" PVC SDR35	8.5"	PSX 12-08 NYLO	12"	12.129"	0"	0"
Invert 2	777.47'	233°	117.875"	8" PVC SDR35	8.5"	PSX 12-08 NYLO	12"	12.129"	1.25"	0"
Invert 3										
Invert 4										
Invert 5										
Invert 6										
Invert 7										
Invert 8										

RIGHT-SIDE UP VIEW (int. dimensions)

UPSIDE-DOWN VIEW (int. dimenions)

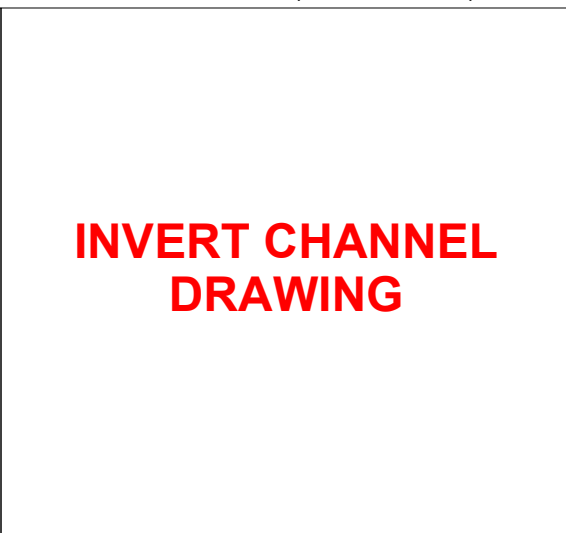
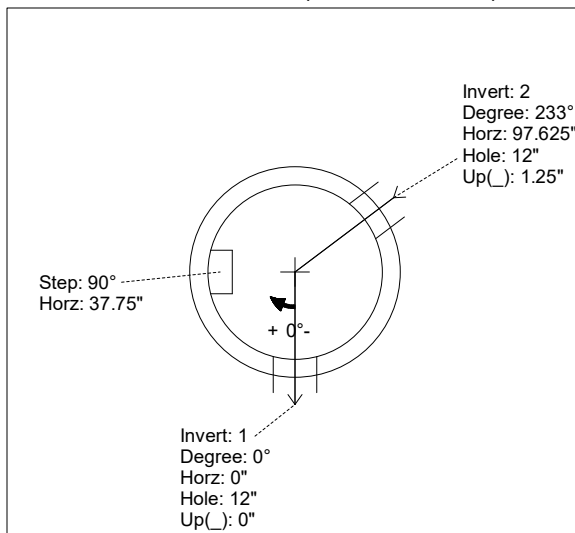
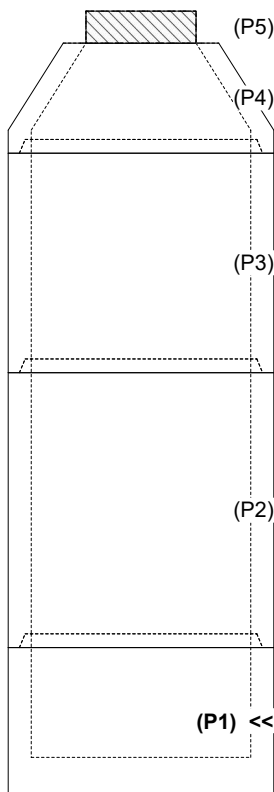

INSIDE WALL DIMENSIONS

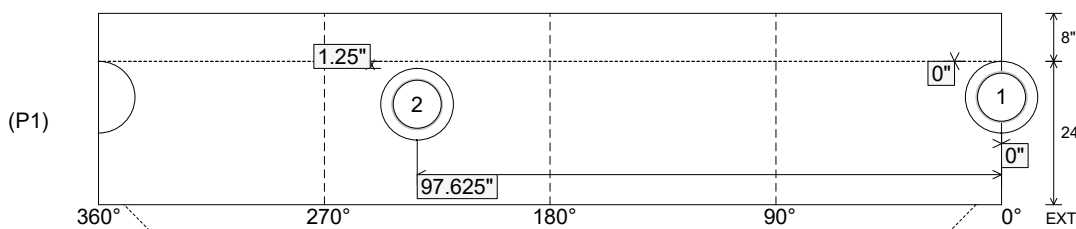

Coating (Int):  
 Coating (Ext):

Seam Up: Tongue  
 Seam Dn: n/a

Wall Thickness: 5"  
 Floor Height: 8"

Height (Int): 24"  
 Height (Ext): 32"

Weight (Net): 3354 lb  
 Volume (Net): 0.86cu.yd