

Job Name: 25-3118 - W6 Ph 2-C Force Main Improvements
 Job Location: Fort Mitchell, KY 41017
 Contractor: Lykins Contracting

Plant: 100

Tech: J. Horsley - A

3/20/2026 1:22:18 PM

PC: Celina Goff



Structure ID: 2301576

P1 MH060BAVF

MH BASE Custom Ht T/n

- P3) 24" - CASTING HEIGHT - 7"
- P2) 60" - MH FLAT TOP w/ 24" ECC Hole F/G - 13"
- P1) 60" - MH BASE Custom Ht T/n - 58"
- 1) 60" - MH INVERT CHANNEL - FULL HEIGHT
- 1) 60" - Conseal CS-102 1.00" (Double)
- 1) Kor-N-Seal2 - S206-18L
- 1) PSX - 12-08 NYLO
- 5) MH Step ML-10-TDS-NCR - 10"

	0 lb
	2869 lb
	8601 lb
	2692 lb
	0 lb
	6 lb
	8 lb
	0 lb
Structure Total:	14176 lb

- Structure Notes:**
1. PER ASTM C-478 SPECIFICATIONS
 2. CONCRETE: 4,000 PSI AT 28 DAYS
 3. REINFORCEMENT:
 - WALLS: PER ASTM A615 - DOUBLE MAT
 - FLOOR: #5 BAR @ 12" C.C. E.W. (GRADE 60) - 2" MIN. REBAR CLEARANCE (TYP)
 4. INVERT CHANNEL REQUIRED
 5. STEPS AT 270 DEGREES
 6. 7" CASTING SUPPLIED BY OTHERS

Rim: 737.35' Rim to Invert: 6.46' Slack: 1.52' Sump: 2" Step Position: 270°

Position	Elev	Angle	Ext. (cw)	Pipe	Pipe OD	Connector	Hole	Horz Size	Up ()	Offset
Invert 1	730.89'	0°	0"	15" PVC SDR35	15.3"	Kor-N-Seal2 S206-18L	18"	18.282"	0.5"	0"
Invert 2	731.03'	92°	57.75"	8" PVC SDR35	8.5"	PSX 12-08 NYLO	12"	12.081"	1.625"	0"
Invert 3										
Invert 4										
Invert 5										
Invert 6										
Invert 7										
Invert 8										

RIGHT-SIDE UP VIEW (int. dimensions)

UPSIDE-DOWN VIEW (int. dimenions)

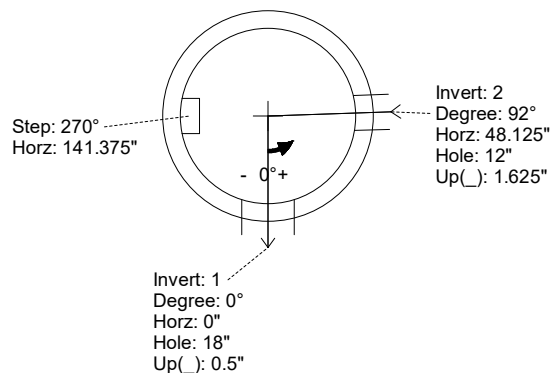
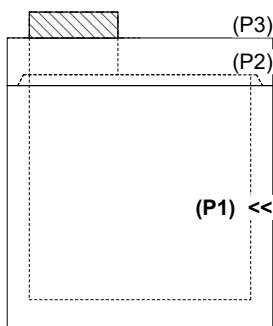

INSIDE WALL DIMENSIONS

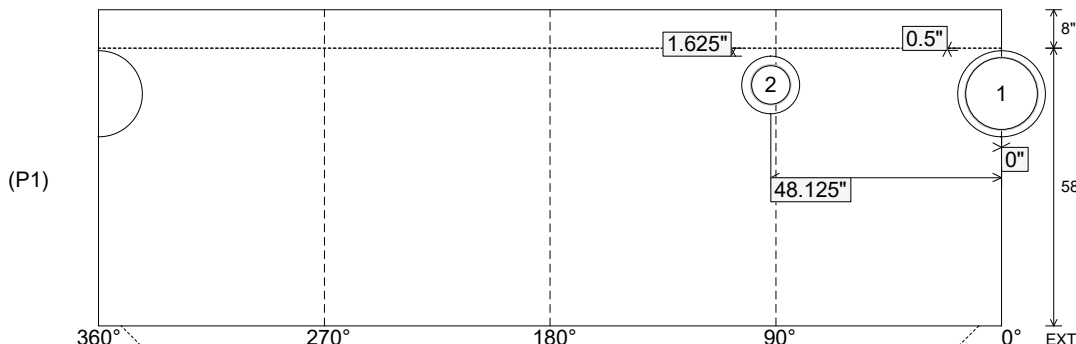

Coating (Int):
Coating (Ext):

Seam Up: Tongue
Seam Dn: n/a

Wall Thickness: 6"
Floor Height: 8"

Height (Int): 58"
Height (Ext): 66"

Weight (Net): 8601 lb
Volume (Net): 2.2cu.yd

Job Name: 25-3118 - W6 Ph 2-C Force Main Improvements
 Job Location: Fort Mitchell, KY 41017
 Contractor: Lykins Contracting

Plant: 100

Tech: J. Horsley - A

3/20/2026 1:22:18 PM

PC: Celina Goff



Structure ID: 2301576

P1 MH060BAVF

MH BASE Custom Ht T/n

- P3) 24" - CASTING HEIGHT - 7"
- P2) 60" - MH FLAT TOP w/ 24" ECC Hole F/G - 13"
- P1) 60" - MH BASE Custom Ht T/n - 58"
- 1) 60" - MH INVERT CHANNEL - FULL HEIGHT
- 1) 60" - Conseal CS-102 1.00" (Double)
- 1) Kor-N-Seal2 - S206-18L
- 1) PSX - 12-08 NYLO
- 5) MH Step ML-10-TDS-NCR - 10"

0 lb
 2869 lb
 8601 lb
 2692 lb
 0 lb
 6 lb
 8 lb
 0 lb

 Structure Total: 14176 lb

Structure Notes:

1. PER ASTM C-478 SPECIFICATIONS
2. CONCRETE: 4,000 PSI AT 28 DAYS
3. REINFORCEMENT:
 - WALLS: PER ASTM A615 - DOUBLE MAT
 - FLOOR: #5 BAR @ 12" C.C. E.W. (GRADE 60) - 2" MIN. REBAR CLEARANCE (TYP)
4. INVERT CHANNEL REQUIRED
5. STEPS AT 270 DEGREES
6. 7" CASTING SUPPLIED BY OTHERS

Rim: 737.35' Rim to Invert: 6.46' Slack: 1.52' Sump: 2" Step Position: 270°

Position	Elev	Angle	Ext. (cw)	Pipe	Pipe OD	Connector	Hole	Horz Size	Up ()	Offset
Invert 1	730.89'	0°	0"	15" PVC SDR35	15.3"	Kor-N-Seal2 S206-18L	18"	18.282"	0.5"	0"
Invert 2	731.03'	92°	57.75"	8" PVC SDR35	8.5"	PSX 12-08 NYLO	12"	12.081"	1.625"	0"
Invert 3										
Invert 4										
Invert 5										
Invert 6										
Invert 7										
Invert 8										

RIGHT-SIDE UP VIEW (int. dimensions)

UPSIDE-DOWN VIEW (int. dimenions)

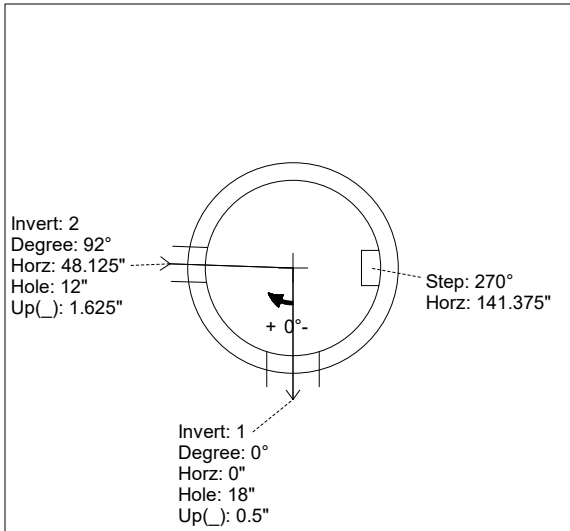
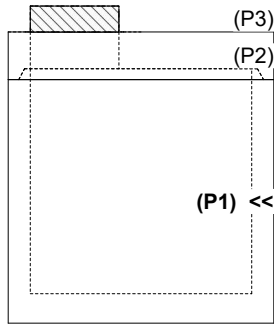

INVERT CHANNEL
DRAWING

INSIDE WALL DIMENSIONS

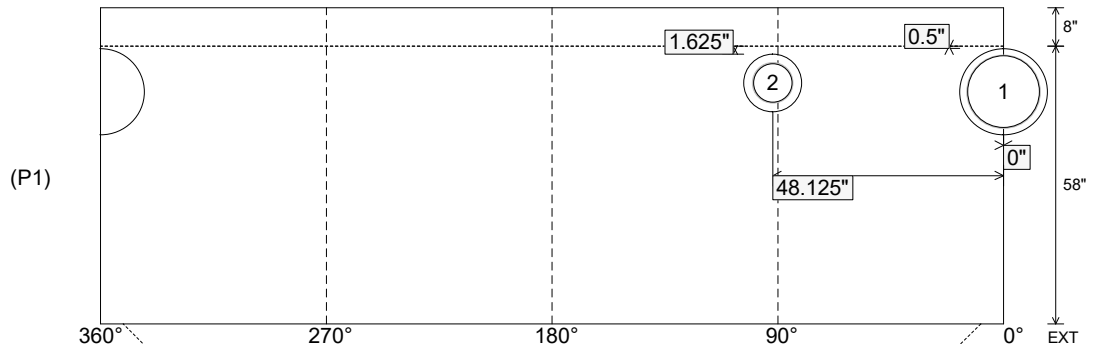

Coating (Int):
 Coating (Ext):

Seam Up: Tongue
 Seam Dn: n/a

Wall Thickness: 6"
 Floor Height: 8"

Height (Int): 58"
 Height (Ext): 66"

Weight (Net): 8601 lb
 Volume (Net): 2.2cu.yd