

Job Name: 25-3118 - W6 Ph 2-C Force Main Improvements  
 Job Location: Fort Mitchell, KY 41017  
 Contractor: Lykins Contracting

Plant: 100

3/27/2026 11:41:32 AM

Tech: J. Horsley - A

PC: Celina Goff



**Structure ID: 2301575**

**P3 MH060LD13**

**MH FLAT TOP w/ 24" ECC Hole F/G**

- P4) 24" - CASTING HEIGHT - 7"
- P3) 60" - MH FLAT TOP w/ 24" ECC Hole F/G - 13"
- P2) 60" - MH RISER T/G - 48"
- P1) 60" - MH BASE T/n - 48"
- 1) 60" - MH INVERT CHANNEL - FULL HEIGHT
- 2) 60" - Conseal CS-102 1.00" (Double)
- 2) Kor-N-Seal2 - S206-18L
- 1) PSX - 12-08 NYLO
- 8) MH Step ML-10-TDS-NCR - 10"

	0 lb
	2869 lb
	5011 lb
	7427 lb
	2692 lb
	0 lb
	12 lb
	8 lb
	0 lb
Structure Total:	18019 lb

- Structure Notes:
1. PER ASTM C-478 SPECIFICATIONS
  2. CONCRETE: 4,000 PSI AT 28 DAYS
  3. REINFORCEMENT: #5 BAR @ 6" C.C. E.W. (GRADE 60) - 2" MIN. REBAR CLEARANCE (TYP)
  4. 7" CASTING SUPPLIED BY OTHERS
  5. LIFTERS: 3 EA. WRA016 CONAC WIRE ROPE ANCHORS FOR PLANT & FIELD HANDLING
  6. TOP SURFACE TO RECEIVE FLOATED FINISH

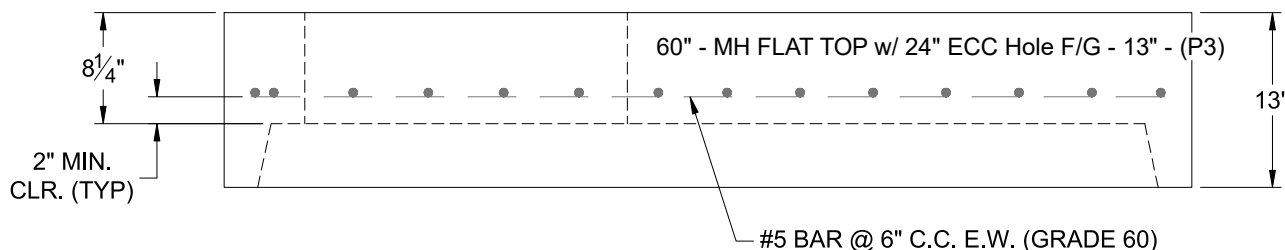
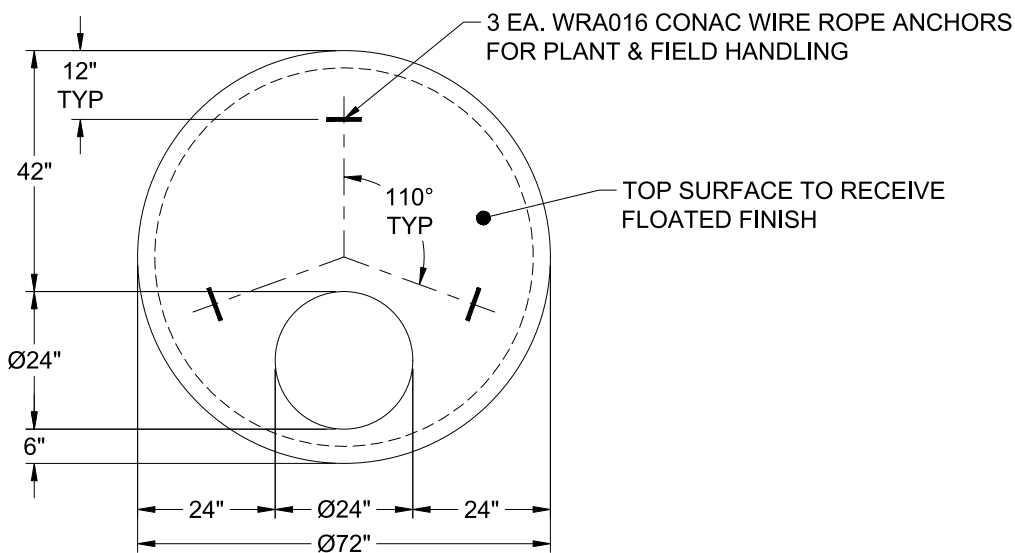

Coating (Int):  
 Coating (Ext):

Seam Up: Flat  
 Seam Dn: Groove

Wall Thickness: 6"

Height (Ext): 13"

Weight (Net): 2869 lb  
 Volume (Net): 0.73cu.yd